

AHRI Standard 420-2023 (I-P)

2023 Standard for

**Performance Rating of
Forced-circulation
Free-delivery Unit Coolers**



we make life better®

2311 Wilson Boulevard, Suite 400
Arlington, VA 22201, USA
www.ahrinet.org
PH 703.524.8800
FX 703.562.1942



©Copyright 2023, by Air-Conditioning, Heating, and Refrigeration Institute
Registered United States Patent and Trademark Office
Printed in U.S.A.

**IMPORTANT
SAFETY DISCLAIMER**

AHRI does not set safety standards and does not certify or guarantee the safety of any products, components or systems designed, tested, rated, installed or operated in accordance with this standard/guideline. It is strongly recommended that products be designed, constructed, assembled, installed, and operated in accordance with nationally recognized safety standards and code requirements appropriate for products covered by this standard/guideline.

AHRI uses its best efforts to develop standards/guidelines employing state-of-the-art and accepted industry practices. AHRI does not certify or guarantee that any tests conducted under its standards/guidelines will be non-hazardous or free from risk.

ICS Code: 27.200

Note:

This standard supersedes AHRI Standard 420-2016 (I-P).

For SI ratings, see AHRI Standard 421-2023 (SI).

AHRI Certification Program Disclaimer

AHRI Standards are developed independently of AHRI Certification activities and can have scopes that include products that are not part of the AHRI Certification Program. The scope of the applicable AHRI Certification Program can be found on AHRI's website at <http://www.ahrinet.org>.

Intent

This standard is intended for the guidance of the industry, including manufacturers, engineers, installers, contractors, and users.

Review and Amendment

This standard is subject to review and amendment as technology advances.

2023 Edition

This edition of AHRI 420, *Performance Rating of Forced-circulation Free-delivery Unit Coolers*, was prepared by the Industrial Refrigeration Standards Technical Committee. It was approved by the Refrigeration Standards Subcommittee on 22 June 2023.

Origin and Development of AHRI Standard 420

The initial publication was ARI Standard 420-1989, *Unit Coolers for Refrigeration*. Subsequent revisions were:

- ARI Standard 420-1994, *Unit Coolers for Refrigeration*
- ARI Standard 420-2000, *Unit Coolers for Refrigeration*
- AHRI Standard 420-2008, *Performance Rating of Forced-Circulation Free-delivery Unit Coolers for Refrigeration*
- AHRI Standard 420 (I-P)-2016, *Performance Rating of Forced-Circulation Free-delivery Unit Coolers for Refrigeration*

Summary of Changes

AHRI Standard 420-2023 (I-P) contains the following updates to the previous edition:

- Updated equations for the inclusion of heat exchanger heat loss/gain in [Appendix C](#).
- Updated [Figure 3](#) to better represent the liquid overfeed method
- Added R-744 to [Table 4](#)
- Updated definitions to include heat exchanger heat loss/gain

Committee Personnel
Industrial Refrigeration Standards Technical Committee

Participant	Interest Category Classification	Voting Member Role	State / Country
Chuck Hall HTPG	Product Manufacturer	Chair	AL, USA
Greg Derosier Evapco	Product Manufacturer	Primary	MD, USA
Ian Runsey Guentner	Product Manufacturer	Primary	IL, USA
Shri Gopalan Evapco	Product Manufacturer	Alternate to Greg Derosier	MD, USA
Trevor Hegg Evapco	Product Manufacturer	Alternate to Greg Derosier	MD, USA
Greg Kalinyak	AHRI Staff Liaison		

Industrial Refrigeration Standards Technical Committee Scope:

The Industrial Refrigeration Standards Technical Committee (STC) is responsible for the development and maintenance of AHRI standards and guidelines pertaining to the performance ratings of Industrial Refrigeration equipment which includes Industrial Unit Coolers, and Industrial Heat Rejection Equipment.

Refrigeration Standards Subcommittee

Participant	Interest Category Classification	Voting Member Role	State / Country
Mike Straub Heat Transfer Products Group, LLC (HTPG)	Product Manufacturer	Chair	GA, USA
Steve Combs Everidge	Product Manufacturer	Primary	
Kunal Bansal Heatcraft Worldwide Refrigeration LLC	Product Manufacturer	Primary	GA, USA
Scott Martin Hillphoenix	Product Manufacturer	Primary	GA, USA
Ron Shebik Hussmann Corporation	Product Manufacturer	Primary	MO, USA
Vince Zolli KeepRite Refrigeration	Product Manufacturer	Primary	ON, Canada
Jennifer Kane Trane Technologies	Product Manufacturer	Primary	Washington, D.C., USA
Daryl Erbs Welbilt, Inc.	Product Manufacturer	Primary	FL, USA
Bruce Hierlmeier Zero Zone, Inc	Product Manufacturer	Primary	WI, USA
Neil Rathje Hillphoenix	Product Manufacturer	Alternate to Scott Martin	VA, USA
Karl Best	AHRI Staff Liaison		

Refrigeration Standards Subcommittee Scope:

The scope of the Refrigeration Standards Subcommittee is standards and guidelines related to the end products that are part of the AHRI Refrigeration Industry Sector. (The definition of and list of products associated with each sector are found on the AHRI website.

These lists represent the membership at the time the Standards Technical Committee and Standards Subcommittee were balloted on the final text of this edition. Since that time, changes in the membership may have occurred. Membership on these committees shall not in and of itself constitute an endorsement by the committee members or their employers of any document developed by the committee on which the member serves.

TABLE OF CONTENTS

PAGE

SECTIONS

Section 1. Purpose	1
Section 2. Scope.....	1
2.1 Scope.....	1
2.2 Exclusions	1
Section 3. Definitions	1
3.1 Expressions of Provision	1
3.2 Standard Specific Definitions.....	2
Section 4. Test Requirements	3
4.1 Test Requirements.....	3
4.2 Instrumentation Requirements	4
4.3 Test Run	4
Section 5. Rating Requirements.....	5
5.1 Standard Ratings	5
5.2 Application Ratings.....	5
5.3 Tolerances	5
Section 6. Minimum Data Requirements for Published Ratings	5
6.1 Minimum Data Requirements for Published Ratings.....	5
6.2 Required Published Ratings	6
Section 7. Marking and Nameplate Data	6
Section 8. Conformance Conditions	6

FIGURES

Figure 1 Method 1: DX – Dual Instrumentation.....	27
Figure 2 Method 2: DX – Calibrated Box.....	28
Figure 3 Method 3: Liquid Overfeed.....	29

TABLES

Table 1 Standard Rating Conditions	4
Table 2 Instrumentation Accuracy.....	5
Table 3 Test Readings	11
Table 4 Additional Test Conditions.....	13
Table 5 Test Condition Tolerances	13
Table 6 Refrigerant Temperature Tolerances	14

APPENDICES

Appendix A. References – Normative	7
Appendix B. References – Informative.....	8

Appendix C. Methods of Testing Forced-circulation Free-delivery Unit Coolers for Refrigeration – Normative9

PERFORMANCE RATING OF FORCED-CIRCULATION FREE-DELIVERY UNIT COOLERS

Section 1. Purpose

This standard establishes definitions, test requirements, rating requirements; minimum data requirements for *published ratings*, marking and nameplate data, and conformance conditions for *forced-circulation free-delivery unit coolers* for refrigeration.

Section 2. Scope

2.1 Scope

This standard applies to factory-made, *forced-circulation free-delivery unit coolers*, as defined in [Section 3](#), operating with a *volatile refrigerant* fed by either direct expansion or liquid overfeed at wet or dry conditions, or both.

2.2 Exclusions

This standard does not apply to:

- 1) Air-conditioning units used primarily for comfort cooling where testing methods are given in other standards
- 2) *Unit coolers* operating at latent load conditions with *refrigerant saturation temperature* < 32°F to prevent frost
- 3) *Unit coolers* installed in or connected to ductwork
- 4) *Unit coolers* using zeotropic refrigerants with *glides* greater than 2.0°F
- 5) Field testing of *unit coolers*

Section 3. Definitions

All terms in this document shall follow the standard industry definitions in the ASHRAE Terminology website unless otherwise defined in this section.

3.1 Expressions of Provision

Terms that provide clear distinctions between requirements, recommendations, permissions, options, and capabilities.

3.1.1 “Can” or “cannot”

Express an option or capability.

3.1.2 “May”

Signifies a permission expressed by the document.

3.1.3 “Must”

Indication of unavoidable situations and does not mean that an external constraint referred to is a requirement of the document.

3.1.4 “Shall” or “shall not”

Indication of mandatory requirements to strictly conform to the standard and where deviation is not permitted.

3.1.5 “Should” or “should not”

Indication of recommendations rather than requirements. In the negative form, a recommendation is the expression of potential choices or courses of action that is not preferred but not prohibited.

3.2 Standard Specific Definitions

3.2.1 Dew Point

Refrigerant vapor saturation temperature at a specified pressure.

3.2.2 Enthalpy Difference (HD)

The difference between the enthalpy of the air entering the unit cooler and the calculated enthalpy of saturated air at the *refrigerant saturation temperature* at the unit cooler outlet, Btu/lb.

3.2.3 Forced-circulation Free-delivery Unit Coolers (Unit Coolers)

A factory-made assembly, including means for forced air circulation and elements where heat is transferred from air to refrigerant without any element external to the cooler imposing air resistance. These can be referred to as air coolers, cooling units, air units or evaporators.

3.2.3.1 Direct Expansion Unit Cooler

A *unit cooler* where the leaving refrigerant vapor is superheated.

3.2.3.2 Liquid Overfeed Unit Cooler

A *unit cooler* where the refrigerant liquid is supplied at a *recirculation rate* greater than one.

3.2.4 Glide

The absolute value of the difference between the starting and ending temperatures of a phase-change process (condensation or evaporation) for a zeotropic refrigerant exclusive of any liquid subcooling or vapor superheating.

3.2.5 Gross Total Cooling Effect (Cooling Capacity)

The heat absorbed by the refrigerant, Btu/h. This is the sum of the *net total cooling effect* and the heat equal to the energy required to operate the *unit cooler*. This includes both sensible and latent cooling.

3.2.6 Net Total Cooling Effect

The refrigeration capacity for space and product cooling, expressed in Btu/h, and is equal to the *gross total cooling effect* less the heat equal to energy required to operate the *unit cooler*. This includes both sensible and latent cooling.

3.2.7 Overfeed Ratio

The mass ratio of liquid to vapor at the outlet of the *liquid overfeed unit cooler*. This can be referred to as “overfeed rate”.

3.2.8 Published Rating

A statement of the assigned values of those performance characteristics, under stated *rating conditions*, where a unit can be chosen to fit the application. These values apply to all units of the same nominal size and type (identification) produced by the same manufacturer. This includes the rating of all performance characteristics shown on the unit or published in specifications, advertising or other literature controlled by the manufacturer, at stated *rating conditions*.

3.2.8.1 Application Rating

A rating based on tests performed at *rating conditions* other than *standard rating conditions*.

3.2.8.2 Standard Rating

A rating based on tests performed at *standard rating conditions*.

3.2.9 Rated Power

- 1) For single phase motors, total fan motor input power, W or kW
- 2) For polyphase motors, individual fan motor output power, hp

3.2.10 Rating Conditions

Any set of operating conditions where a single level of performance results and causes only that level of performance to occur.

3.2.11 Standard Rating Conditions

Rating conditions used as the basis of comparison for performance characteristics.

3.2.11.1 Dry Rating Condition

Rating condition where latent cooling is not present.

3.2.11.2 Wet Rating Condition

Rating condition where both sensible and latent cooling are present, and the coil surface temperature is above freezing.

3.2.12 Recirculation Ratio (Recirculation Rate)

The mass ratio of liquid circulated to the amount of liquid vaporized.

3.2.13 Refrigerant Saturation Temperature

Refrigerant temperature at the *unit cooler* inlet or outlet determined either by measuring the temperature at the outlet of the two-phase refrigerant flow, for a *liquid overfeed unit cooler*, or by measuring refrigerant pressure and determining the corresponding temperature from reference thermodynamic tables or equations for the refrigerant, °F. For zeotropic refrigerants, the corresponding temperature to a measured pressure is the refrigerant *dew point*.

3.2.14 Standard Air Conditions

Dry air at 70°F and absolute pressure 29.92 in Hg. Under these conditions, dry air has a mass density of 0.075 lb/ft³.

3.2.15 Steady-state Conditions

An operating state of a system, including the system surroundings, where the extent of change with time is within the limits specified in [Table 5](#) and [Table 6](#).

3.2.16 Temperature Difference (TD)

The difference between the dry-bulb temperature of the air entering the *unit cooler* and *refrigerant saturation temperature* at the *unit cooler* outlet, °F.

3.2.17 Test Measurement

The reading of a specific test instrument at a specific point in time. Can be averaged with other measurements of the same parameter at the same time to determine a *test reading* or averaged over the duration of the test to determine the value for the test run.

3.2.18 Test Reading

The recording of one full set of the *test measurements* required to assess the performance of the test unit.

3.2.19 Test Series

A group of test runs performed on the same test unit to determine performance at all required *rating conditions*.

3.2.20 Volatile Refrigerant

A refrigerant that changes from liquid to vapor in the process of absorbing heat.

Section 4. Test Requirements

4.1 Test Requirements

All *standard ratings* of *unit coolers* shall be verified by tests conducted at *standard rating conditions*, [Table 1](#), in accordance with one of the methods set forth in [Appendix C](#).

- 1) All regularly furnished equipment that affects performance shall be in place during the test
- 2) The refrigerant used during the test shall be one that is published for use with the *unit cooler*
- 3) Each *standard rating* test shall be performed at either 50 Hz or 60 Hz and at the highest rated voltage as specified by the manufacturer on the unit or motor nameplate

Table 1 Standard Rating Conditions

Condition Number	Coil Rating Condition	Entering Air				Refrigerant Saturation Temperature ² , °F	TD, °F
		Dry-bulb Temperature, °F	Wet-bulb Temperature, °F	Relative Humidity ¹ , %	Dew Point Temperature ¹ , °F		
1	Wet	50.0	46.1	75	-	35.0	15
2	Dry	50.0	-	< 45	< 30.0	35.0	15
3	Dry	35.0	-	< 50	< 20.0	25.0	10
4	Dry	10.0	-	< 46	< -5.0	0.00	10
5	Dry	-10.0	-	< 43	< -25.0	-20.0	10

Notes:

1. The coil *dry rating condition* can be confirmed by measuring either the entering air *dew point* or relative humidity according to the instrumentation requirements of Table 2. At coil *wet rating condition*, relative humidity is for reference only.
2. Measured at coil outlet.

4.2 Instrumentation Requirements

Precision instruments and automated electronic data acquisition equipment shall be used to measure and record temperature, pressure, and refrigerant flow rate test parameters. Advanced technologies or methods of measurement not described in this standard can be used, provided the accuracy requirements of this standard are achieved by the alternative method.

4.2.1 Calibration

All measuring instruments and instrument systems (for example data acquisition coupled to temperature, pressure, or flow sensors) shall be calibrated by comparison to primary or secondary standards with calibrations traceable to National Institute of Standards and Technology (NIST) measurements, other recognized national laboratories, or derived from accepted values of natural physical constants. All test instruments shall be calibrated annually, whenever damaged, or when the accuracy is called into question.

4.2.2 Selection and Accuracy

All measuring instruments shall be selected to meet or exceed the accuracy criteria listed in Table 2 for each type of measurement.

4.3 Test Run

Test readings compiled during *unit cooler* operation when *steady-state conditions* have been maintained. The test run shall last for a minimum of thirty minutes with at least fifteen consecutive *test readings*, and all shall comply with the requirements of [Table 1](#), [Table 2](#), [Table 3](#), [Table 4](#), [Table 5](#), and [Table 6](#). The test run includes all the information required to determine *unit cooler* performance at a specific *rating condition*.

Table 2 Instrumentation Accuracy

Measurement	Medium	Minimum Accuracy	Instrument Examples
Temperature	Air dry-bulb	± 0.10°F	Resistance temperature device (RTD) thermistor
	Air wet-bulb		
	Refrigerant liquid		
	Refrigerant vapor	± 0.5°F	Special calibrated thermocouple
	Air dew point	± 0.5°F	Chilled mirror hygrometer
	Others	± 1.0°F	Liquid-in-glass thermometer
Relative Humidity ¹	Air	± 3 percentage points Rh	Capacitive or resistive Rh sensor
Pressure	Refrigerant	Pressure corresponding to ± 0.2°F of saturation temperature	Transducer
	Air	± 0.05 inches of mercury	Barometer
Flow	Refrigerant	1% of reading	Mass flow meter
	Liquids	1% of reading	Venturi
Electrical	Motor kilowatts/amperes/voltage	1% of reading	Power meter
	Auxiliary kilowatt input (for example heater)		Amp probe Multimeter
Speed	Motor/fan shaft	1% of reading	Tachometer
Weight	Oil/refrigerant solution	0.5% of reading	Gravimeter (scale or analytical balance)
Specific Gravity	Brine	1% of reading	Hydrometer
Time	Hours/minutes/seconds	0.5% of time interval	Electronic clock
Note:			
1. Relative humidity and air dew point measurements can be used to confirm the dry coil condition for test condition numbers 2 through 5 from Table 1.			

Section 5. Rating Requirements

5.1 Standard Ratings

Standard ratings shall include *rated power* and *gross total cooling effect* established at all applicable *standard rating conditions* specified in [Table 1](#).

5.2 Application Ratings

Application ratings shall include *rated power* and *gross total cooling effect* at conditions other than *standard rating conditions*. Application ratings with refrigerant saturation temperatures below 32°F shall be rated at dry conditions. Application ratings published by the manufacturer shall be clearly identified as *application ratings*.

5.3 Tolerances

To comply with this standard, any representative production unit selected at random, when tested at the *standard rating conditions*, shall have a *gross total cooling effect* not less than 95% of the published *standard rating* and not exceed 105% of the *rated power*.

Section 6. Minimum Data Requirements for Published Ratings

6.1 Minimum Data Requirements for Published Ratings.

As a minimum, *published ratings* shall include all *standard ratings*. All claims to ratings within the scope of this standard shall include the statement “Rated in accordance with AHRI Standard 420”. All claims to ratings outside the scope of this standard shall include the statement “Outside the scope of AHRI Standard 420”. *Application ratings* within the scope of the standard shall include a statement of the conditions under which the ratings apply.

6.2 Required Published Ratings

All published *standard ratings* and *application ratings* shall include:

- 1) Model number
- 2) *Gross total cooling effect*, Btu/h
- 3) *TD*, °F
- 4) Refrigerant designation(s) in accordance with ASHRAE Standard 34
- 5) *Refrigerant saturation temperature*, °F
- 6) *Rated power*, W or hp
- 7) Number of motors
- 8) Coil fin density, fins per inch or coil fin spacing; actual fin density or fin spacing shall be within 10% of published values

Note: The following data should be published in addition to the required *published ratings* per Section [6.2](#):

- 1) Type of defrost
- 2) *Unit cooler* motor current, A; voltage, V; and frequency, Hz
- 3) Defrost heater power, W; and voltage, V (if used)
- 4) Airflow rate, scfm

Section 7. Marking and Nameplate Data

As a minimum, the manufacturer name or tradename; model number; refrigerant(s); current, A; voltage, V; frequency, Hz; and phase shall be shown in a conspicuous place on the unit.

Nameplate voltages for 60 Hz systems shall include one or more of the equipment nameplate voltage ratings shown in Table 1 of AHRI Standard 110. Nameplate voltages for 50 Hz systems shall include one or more of the utilization voltages shown in Table 1 of IEC Standard Publication 60038.

Section 8. Conformance Conditions

While conformance with this standard is voluntary, conformance shall not be claimed or implied for products or equipment within the standard's [Purpose \(Section 1\)](#) and [Scope \(Section 2\)](#) unless such product claims meet all of the requirements of the standard and all of the testing and rating requirements are measured and reported in complete compliance with the standard. Any product that has not met all the requirements of the standard shall not reference, state, or acknowledge the standard in any written, oral, or electronic communication.

APPENDIX A. REFERENCES – NORMATIVE

Listed here are all standards, handbooks, and other publications essential to the formation and implementation of the standard. All references in this appendix are considered as part of the standard.

- A.1. AHRI Standard 110-2016, *Air-Conditioning, Heating, and Refrigerating Equipment Nameplate Voltages*, 2016, Air-Conditioning, Heating, and Refrigeration Institute, 2311 Wilson Blvd, Suite 400, Arlington, VA 22201, U.S.A.
- A.2. ANSI/ASHRAE Standard 34-2019 with Addenda, *Designation and Safety Classification of Refrigerants*, 2019, ASHRAE, 180 Technology Parkway, Peachtree Corners, GA 30092, U.S.A.
- A.3. ANSI/ASHRAE Standard 41.1-2020, *Standard Method for Temperature Measurement*, 2020, ASHRAE, 180 Technology Parkway, Peachtree Corners, GA 30092, U.S.A.
- A.4. ANSI/ASHRAE Standard 41.3-2022, *Standard Method for Pressure Measurement*, 2022, ASHRAE, 180 Technology Parkway, Peachtree Corners, GA 30092, U.S.A.
- A.5. ANSI/ASHRAE Standard 41.4-2015, *Standard Method for Measurement of Proportion of Lubricant in Liquid Refrigerant*, 2015, ASHRAE, 180 Technology Parkway, Peachtree Corners, GA 30092, U.S.A.
- A.6. ANSI/ASHRAE Standard 41.10-2020, *Standard Methods for Refrigerant Flow Measurement Using Flowmeters*, 2020, ASHRAE, 180 Technology Parkway, Peachtree Corners, GA 30092, U.S.A.
- A.7. ANSI/ASHRAE Standard 41.11-2020, *Standard Methods for Power Measurement*, 2020, ASHRAE, 180 Technology Parkway, Peachtree Corners, GA 30092, U.S.A.
- A.8. *ASHRAE Handbook Fundamentals*, 2021, ASHRAE, 180 Technology Parkway, Peachtree Corners, GA 30092, U.S.A.
- A.9. *ASHRAE Psychrometric Analysis* software, Version 7, 2016, ASHRAE, 180 Technology Parkway, Peachtree Corners, GA 30092, U.S.A.
- A.10. ASHRAE Terminology. ASHRAE. Accessed January 20, 2022. <https://www.ashrae.org/technical-resources/free-resources/ashrae-terminology>.
- A.11. IEC Standard Publication 60038-2009, *IEC Standard Voltages*, 2009, International Electrotechnical Commission, 3, rue de Varembé, P.O. Box 131, CH - 1211 GENEVA 20, Switzerland.
- A.12. NIST Reference Fluid Thermodynamic and Transport Properties, *REFPROP*, Version 9.1, 2016, National Institute of Standards and Technology, Boulder, CO 80303, USA.

APPENDIX B. REFERENCES – INFORMATIVE

Listed here are standards, handbooks and other publications which may provide useful information and background but are not considered essential. References in this appendix are not considered part of the standard.

- B.1.** *Ammonia Refrigeration Piping Handbook*, 2014, International Institute of Ammonia Refrigeration, 1001 North Fairfax Street, Suite 503, Alexandria, VA 22314, U.S.A.
- B.2.** ANSI/ASHRAE Standard 41.9-2021, *Standard Methods for Refrigerant Mass Flow Measurements Using Calorimeters*, 2021, ASHRAE, 180 Technology Parkway, Peachtree Corners, GA 30092, U.S.A.

APPENDIX C. METHODS OF TESTING FORCED-CIRCULATION FREE-DELIVERY UNIT COOLERS FOR REFRIGERATION – NORMATIVE

C.1. Purpose

This appendix provides a method of testing for *forced-circulation free-delivery unit coolers* for Refrigeration.

C.2. Scope of Appendix C

These methods of testing apply to factory-made, *forced-circulation free-delivery unit cooler*, as defined in [Section 3](#), operating with a *volatile refrigerant* fed by either direct expansion or liquid overfeed at wet or dry conditions, or both.

These methods of testing do not apply to:

- 1) Air-conditioning units used primarily for comfort cooling that have testing methods in other standards
- 2) *Unit coolers* operating at latent load conditions with *refrigerant saturation temperature* < 32 °F to prevent frost
- 3) *Unit coolers* installed in or connected to ductwork
- 4) *Unit coolers* using zeotropic refrigerants with *glides* greater than 2.0°F
- 5) Field testing of *unit coolers*

C.3. Measurements

Refer [Table 2](#) for required instrumentation accuracy.

C.3.1. Temperature Measurements

- 1) Temperature measurements shall be made in accordance with ASHRAE Standard 41.1.
- 2) Air wet-bulb and dry-bulb temperatures entering the *unit cooler* shall be measured based on the airflow area at the point of measurement. One measuring station is required for each 2.0 ft² of the first 10.0 ft² of airflow area and one additional measuring station is required for each 4.0 ft² of airflow area above 10.0 ft². A minimum of two stations shall be used and the number of measuring stations shall be rounded up to the next whole number.
- 3) The airflow area shall be divided into the required number of equal area rectangles with aspect ratios not greater than two to one. Additional measuring stations can be necessary to meet this requirement. The measuring stations shall be located at the geometric center of each rectangle.
- 4) The maximum allowable deviation between any two air temperature measurement stations shall be 2.0°F.
- 5) If sampling tubes are used, each tube opening can be used as a temperature measuring station provided the openings are uniformly spaced along the tube, the airflow rates entering each port are relatively uniform ($\pm 15\%$) and the arrangement of tubes complies with the location requirements of [C.3.1\(3\)](#). Additionally, a one-time temperature traverse shall be made over the measurement surface, prior to the test to assess the temperature variation and confirm the measuring station complies with the allowable deviation specified in [C.3.1\(4\)](#). Refer to ASHRAE Standard 41.1 for more information and diagrams.
- 6) Refrigerant temperatures entering and leaving the *unit cooler* shall be measured by a temperature measuring instrument placed in a thermometer well and inserted into the refrigerant stream. These wells shall be filled with non-solidifying, thermal conducting liquid or paste to confirm the temperature sensing instrument is exposed to a representative temperature. The entering temperature of the refrigerant shall be measured within six pipe diameters upstream of the control device.

C.3.2. Pressure Measurements

Connections for pressure measurements shall be smooth and flush within the pipe wall and shall be located not less than six pipe diameters downstream from fittings, bends, or obstructions. Refer to ASHRAE Standard 41.3 for more information and diagrams.

C.3.3. Volatile Refrigerant Flow Measurement

- 1) Refrigerant flow meters shall be installed and the flow rate of *volatile refrigerants* shall be measured in accordance with ASHRAE Standard 41.10.
- 2) Refrigerant liquid must be sub-cooled both upstream and downstream of the meter to confirm the liquid remains single phase.
- 3) Refrigerant vapor must be superheated both upstream and downstream of the meter to confirm the vapor remains single phase.
- 4) Flow meters shall be installed with at least ten pipe diameters upstream and five diameters downstream of the meter, in straight pipe free of valves and fittings, or in accordance with the manufacturer's instructions.

Note: A direct reading mass-flowrate measuring device, such as a Coriolis meter, should be used for measuring the refrigerant flow rate. Other flow meters that demonstrate the capability to measure flow rate with the specified accuracy can be used.

C.3.4. Oil-in-refrigerant Mass Ratio Measurement

The ratio of oil to refrigerant shall be less than 1% by weight. Unless the system does not contain refrigerant oil, tests for oil concentration shall be made a minimum of once per *test series* per ASHRAE Standard 41.4.

C.3.5. Rated Power Measurement

Prior to conducting a capacity *test series*, the following shall be measured and recorded, refer to Section [C.11.1](#).

- | | | |
|-----------------|---|--|
| E | - | Total electrical power input to fan motor(s) of <i>unit cooler</i> , W |
| FS | - | Fan speed (s), rpm |
| N | - | Number of motors |
| P _b | - | Barometric pressure, in Hg |
| T _{db} | - | Dry-bulb temperature of air at inlet, °F |
| T _{wb} | - | Wet-bulb temperature of air at inlet, °F |
| V | - | Voltage of each phase, V |

For a given motor winding configuration, the total power input shall be measured at the highest nameplated voltage. For three-phase power, voltage imbalance shall be not more than 2%.

C.3.6. Measurement Intervals

Measurement intervals shall be in accordance with [Table 3](#). Duration of the test run shall be a minimum of thirty minutes.

Table 3 Test Readings

Test Parameter	Minimum Data Collection Rate, Test Readings per Hour	Minimum Number of Test Readings per Test Run²
Temperature	30	15
Pressure	30	15
Refrigerant mass flow rate	30	15
Test room barometric pressure	1	1
Fan speed(s)	1	1
Total electrical power input to fan motor(s) ¹	3	2
Total electrical power input to heater and auxiliary equipment ¹	3	2
Notes: 1. For calibrated box only (method 2)		

C.4. Unit Cooler General Data

The following data shall be recorded, where applicable, for each unit tested, including the units of measurement used.

C.4.1. Physical Data

- 1) Manufacturer name and address
- 2) Identification number (model/serial)
- 3) Size (external dimensions), in × in × in
- 4) Nameplate motor data (for each motor)
 - a) Type
 - b) Frame size
 - c) Power, hp
 - d) Speed, rpm
 - e) Voltage, V
 - f) Amps, A
 - g) Phase
 - h) Frequency, Hz
 - i) Efficiency (NEMA nominal or manufacturer’s certificate for polyphase motors)
 - j) Manufacturer
 - k) Serial number or manufacturer identification number
- 5) Fan data
 - a) Diameter, in
 - b) Width (centrifugal fans only), in
 - c) Speed, rpm
 - d) Number of blades
 - e) Manufacturer
 - f) Model number or part number
 - g) Number of fans

- 6) Cooling coil data
 - a) Finned length, in
 - b) Fin height and depth, in
 - c) Number of rows deep
 - d) Number of tubes high
 - e) Fin density, fins per inch or fin spacing, mm based on total fin count
 - f) If fins are staged, fin density per stage, fins per inch or fin spacing per stage
 - g) Measured fin material thickness, in (

Note: Fin thickness for hot dipped galvanized coils can vary.

- h) Fin material
 - i) Finished fin geometry
 - j) Tube material
 - k) Tube description { meaning, outside diameter (or profile), enhancements }
 - l) Number of refrigerant circuits
 - m) Coil or fin coatings
- 7) Accessories (for example, louvers, distributor orifice, grills)

C.4.2. Specific to the Test

- 1) Test location, test company and address
- 2) Method of test
- 3) Date and time of test run
- 4) Names of observers – responsible engineers and all data takers
- 5) Published *gross total cooling effect at standard rating conditions*, Btu/h
- 6) Refrigerant
- 7) *Recirculation ratio* (method 3) - manufacturer specified
- 8) Refrigerant flow rate, lbm/h (method 3) - manufacturer specified

C.5. Methods of Testing

The *gross total cooling effect* of *unit coolers* shall be determined by one of the following methods. In all methods, the recorded *gross total cooling effect*, q_t , shall be the average of two independent determinations.

C.5.1. Method 1, DX Dual Instrumentation

The *cooling capacity* shall be determined by measuring the enthalpy change and the mass flow rate of the refrigerant across the *unit cooler* using two independent measuring systems, see [Figure 1](#).

C.5.2. Method 2, DX Calibrated Box

The *cooling capacity* shall be determined concurrently by measuring the enthalpy change and the mass flow rate of the refrigerant across the *unit cooler* and the heat input to the calibrated box, see [Figure 2](#).

C.5.3. Method 3, Liquid Overfeed

The *cooling capacity* shall be determined by measuring the enthalpy change and the mass flow rate of the refrigerant across the *unit cooler* and measured with a condenser calorimeter. The refrigerant outlet pressure shall be measured, and the corresponding *refrigerant saturation temperature* shall agree with the measured temperature within 0.2°F. The *recirculation ratio* and refrigerant flow rate through *unit cooler* shall be specified by the manufacturer, see [Figure 3](#).

C.6. Test Chamber Dimensions

The *unit cooler* shall be installed in a room of minimum size to prevent airflow restrictions or recirculation such that:

- 1) Obstacles are not positioned within a distance of $2\sqrt{AB}$ from the discharge of the *unit cooler*, where A and B are the air inlet dimensions, in, per fan section of the *unit cooler*.
- 2) All other distances correspond to the minimum requirements of the installation instructions provided by the manufacturer.
- 3) The minimum volume, ft³, of the test chamber shall be 20% of the airflow rate, ft³/min produced by the *unit cooler* together with all auxiliary air moving devices that operate simultaneously with the *unit cooler*.

C.7. General Test Conditions

Test acceptance criteria listed in [Table 4](#), [Table 5](#) and [Table 6](#) apply to all methods of test:

Table 4 Additional Test Conditions

Method	Condition Number	Inlet Saturation Temperature, °F		Inlet Subcooling, °F	Outlet Superheat, °F
		Excluding R-717	R-717 only		
1, 2	All	105.0 ¹	95.0	15 ²	6.5 ³
3	1	40.0	40.0	3	-
	2	40.0	40.0	3	-
	3	30.0	30.0	3	-
	4	7.0	7.0	4	-
	5	-10.0	-10.0	6	-

Notes:

1. For R-744, 50°F.
2. For R-744, 10°F.
3. For Low superheat less than 5.5°F, use method 3 capacity measurement.

Table 5 Test Condition Tolerances

Variable Description	Test Condition Stability Over Test Run Duration, °F		Allowable Deviation of Average Test Temperatures from <i>Standard Rating Conditions</i> , °F	
	Dry Condition	Wet Condition	Dry Condition	Wet Condition
Dry-bulb Temperature	-	-	±1.0	±1.0
Wet-bulb Temperature	-	±0.5	-	±0.5
<i>Dew point</i> Temperature	-	-	Note 2	-
<i>Temperature difference</i>	±0.5 ¹	±0.5 ¹	-	-
Refrigerant Flow Rate	±3.0%		-	-

Notes:

1. The dry-bulb temperature tolerance is set by the *TD*.
2. The *dew point* temperature cannot exceed the temperature shown in [Table 1](#).

Table 6 Refrigerant Temperature Tolerances

Variable Description	Test Temperature Stability During the Test Run, °F		Allowable Deviation of Average Test Temperatures from <i>standard rating conditions</i> , °F	
	Methods 1, 2	Method 3	Methods 1, 2	Method 3
Inlet Saturation Temperature	±5.0	±2.0	±2.5	±1.0
Inlet Subcooling	±5.0	±1.0 ¹	±2.0	±1.0
Outlet Saturation Temperature	-	-	±0.5	±0.5
Outlet Superheat	±1.5	-	±1.0	-

Note:
 1. For Test Condition 5, ±2.0 °F.

C.8. DX Dual Instrumentation Test Procedure (Method 1)

C.8.1. Test Setup and Procedure

Refer to Section [C.5](#), [C.6](#), [C.7](#) and [Figure 1](#) for specific test setup.

C.8.2. Measured and Recorded Data

- 1) Air side (as required for dry or wet coil conditions)
 - FS - Fan speed (s), rpm
 - P_b - Barometric pressure, in Hg
 - rh - Air inlet relative humidity, %
 - T_{db} - Dry-bulb temperature of air at inlet, °F
 - T_{dp} - Dew point temperature of air at inlet, °F
 - T_{wb} - Wet-bulb temperature of air at inlet, °F
- 2) Refrigerant side
 - P_{0a}, P_{0b} - Pressure of subcooled refrigerant liquid entering the expansion valve, psi
 - P_{2a}, P_{2b} - Pressure of superheated refrigerant vapor leaving the *unit cooler*, psi
 - t_{0a}, t_{0b} - Temperature of subcooled refrigerant liquid entering the expansion valve, °F
 - t_{2a}, t_{2b} - Temperature of superheated refrigerant vapor leaving the *unit cooler*, °F
 - w_{v1} - Mass flow rate of subcooled refrigerant liquid through M1, lbm/h
 - w_{v2} - Mass flow rate of subcooled refrigerant liquid through M2 or superheated refrigerant vapor through M2ALT, lbm/h

C.8.3. Calculations

(Refer to Section [C.11](#) for calculated values)

- 1) For each independent refrigerant mass flow measurement at a *dry rating condition*, calculate the *gross total cooling effect*, refer to [C.12.1.1](#).
- 2) For each independent refrigerant mass flow measurement at a *wet rating condition*, calculate the *gross total cooling effect*, refer to [C.12.1.2](#)
- 3) Calculate the *gross total cooling effect* and heat balance, refer to [C.12.1.3](#) and [C.12.1.4](#).

C.9. DX Calibrated Box Test Procedure (Method 2)

C.9.1. Test Setup and Procedure

Refer to Section [C.5](#), [C.6](#), [C.7](#) and [Figure 2](#) for specific test setup.

C.9.1.1. Apparatus Setup for Calibrated Box Calibration and Test

- 1) The calibrated box shall be installed in a temperature-controlled enclosure where the temperature can be maintained at a constant level.
- 2) The temperature-controlled enclosure shall be of a size that provides clearances of not less than 18 in at all sides, top and bottom, except that clearance of any one surface can be reduced to not less than 5.5 in.
- 3) The heat leakage of the calibrated box shall not exceed 30% of the *gross total cooling effect* of the *unit cooler* under test. The ability to maintain a low temperature in the temperature-controlled enclosure reduces the heat leakage into the calibrated box and can extend the application range.
- 4) Refrigerant lines within the calibrated box shall be well insulated to prevent heat loss or gain.
- 5) Instruments for measuring the temperature around the outside of the calibrated box shall be located at the center of each wall, ceiling, and floor at a distance of 6 in from the calibrated box. : In the case where a clearance around the outside of the calibrated box, as indicated above, is reduced to less than 18 in, the number of temperature measuring devices on the outside of that surface shall be increased to six, and shall be treated as a single temperature to be averaged with the temperature of each of the other five surfaces. When the clearance is reduced below 12 in (one surface only), the temperature measuring instruments shall be located midway between the outer wall of the calibrated box and the adjacent wall. The six temperature measuring instruments shall be located at the center of six rectangular sections of equal area.
- 6) Heating means inside the calibrated box shall be shielded or installed in a manner to prevent radiation to the *unit cooler*, the temperature measuring instruments, and to the walls of the box. The heating means shall be constructed to prevent stratification of temperature, and means shall be provided for distributing the temperature uniformly.
- 7) The average air dry-bulb temperature in the calibrated box during *unit cooler* tests and calibrated box heat leakage tests shall be the average of eight temperatures measured at the corners of the box at 2 in to 4 in from the walls. The instruments shall be shielded from any cold or warm surfaces. The instruments shall not be shielded from the adjacent walls of the box. The *unit cooler* under test shall be mounted such that the temperature instruments are not in the direct air stream from the discharge of the *unit cooler*.

C.9.1.2. Calibration of the Calibrated Box

A calibration test shall be made for the maximum and the minimum forced air movements expected in the use of the calibrated box. The calibration heat leakage shall be plotted as a straight line function of these two air quantities and the curve shall be used as calibration for the box.

- 1) The heat input shall be adjusted to maintain an average box temperature not less than 25.0°F above the test enclosure temperature.
- 2) The average dry-bulb temperature inside the calibrated box shall not vary more than 1.0°F over the course of the calibration test.
- 3) A calibration test shall be the average of eleven consecutive hourly readings when the box has reached a steady-state temperature condition.
- 4) The box temperature shall be the average of all readings after a steady-state temperature condition has been reached.
- 5) The calibrated box has reached a steady-state temperature condition when all three of the following conditions are met:
 - a) The average box temperature is not less than 25.0°F above the test enclosure temperature.

- b) Temperature variations do not exceed 5.0°F between temperature measuring stations.
- c) Temperatures do not vary by more than 2.0°F at any one temperature-measuring station.

C.9.2. Data to be Measured and Recorded

- 1) Air side (as required for dry coil conditions)
 - E - Total electrical power input to fan motor(s) of *unit cooler*, W
 - FS - Fan speed (s), rpm
 - P_b - Barometric pressure, in Hg
 - rh - Air inlet relative humidity, %
 - T_{cb} - Average dry-bulb temperature of air within the calibrated box, °F
 - T_{db} - Dry-bulb temperature of air at inlet, °F
 - T_{dp} - Dew point temperature of air at inlet, °F
 - T_{en} - Average dry-bulb temperature of air within the temperature controlled enclosure, °F
 - T_{wb} - Wet-bulb temperature of air at inlet, °F
- 2) Heat load provided to calibrated box
 - E_c - Total electrical power input to heater and auxiliary equipment, W
- 3) Refrigerant Side
 - P₀ - Pressure of subcooled refrigerant liquid entering the expansion valve, psi
 - P₂ - Pressure of superheated refrigerant vapor leaving the *unit cooler*, psi
 - t₀ - Temperature of subcooled refrigerant liquid entering the expansion valve, °F
 - t₂ - Temperature of superheated refrigerant vapor leaving the *unit cooler*, °F
 - w_{v1} - Mass flow rate of subcooled refrigerant liquid through M1, lbm/h

C.9.3. Calculations

Refer to Section [C.11](#) for calculated values.

- 1) Calculate the heat leakage coefficient of the calibrated box, refer to [C.12.2.1](#).
- 2) For each *dry rating condition*, calculate the air-side *gross total cooling effect*, refer to [C.12.2.2](#).
- 3) For each *dry rating condition*, calculate the refrigerant-side *gross total cooling effect*, refer to [C.12.2.3](#).
- 4) Calculate the *gross total cooling effect* and heat balance, refer to [C.12.2.4](#) and [C.12.2.5](#).

C.10. Liquid Overfeed Test Procedure (Method 3)

C.10.1. Test Setup and Procedure

Refer to Section [C.5](#), [C.6](#), [C.7](#) and [Figure 3](#) for specific test setup.

C.10.2. Data to be Measured and Recorded

- 1) Air side (as required for dry or wet coil conditions)
 - FS - Fan speed (s), rpm
 - P_b - Barometric pressure, in Hg
 - rh - Air inlet relative humidity, %
 - T_a - Local pipe ambient temperature, °F
 - T_{a1} - Condenser calorimeter ambient temperature, °F
 - T_{a2} - Liquid/vapor separator ambient temperature, °F
 - T_{db} - Dry-bulb temperature of air at inlet, °F

- T_{dp} - Dew point temperature of air at inlet, °F
- T_{wb} - Wet-bulb temperature of air at inlet, °F

2) Refrigerant Side

- P_0 - Pressure of subcooled refrigerant liquid entering the expansion valve, psi
- P_3 - Pressure of saturated refrigerant liquid/vapor mixture leaving the *unit cooler*, psi
- P_4 - Pressure of refrigerant in liquid/vapor separator, psi
- P_5 - Pressure of refrigerant entering condenser calorimeter, psi
- P_6 - Pressure of subcooled refrigerant liquid leaving condenser calorimeter and entering condensate pump, psi
- P_7 - Pressure of subcooled refrigerant liquid leaving condensate pump, psi
- P_8 - Pressure of subcooled refrigerant liquid entering recirculation pump, psi
- P_9 - Pressure of subcooled refrigerant liquid leaving recirculation pump, psi
- P_{c1} - Pressure of fluid entering condenser calorimeter, psi
- P_{c2} - Pressure of fluid leaving condenser calorimeter, psi
- t_0 - Temperature of subcooled refrigerant liquid entering the expansion valve, °F
- t_3 - Temperature of saturated refrigerant liquid/vapor mixture at outlet, °F
- t_5 - Temperature of refrigerant entering condenser calorimeter, °F
- t_6 - Temperature of subcooled refrigerant liquid entering condensate pump, °F
- t_7 - Temperature of subcooled refrigerant liquid leaving condensate pump, °F
- t_8 - Temperature of subcooled refrigerant liquid entering recirculation pump, °F
- t_9 - Temperature of subcooled refrigerant liquid leaving recirculation pump, °F
- t_{c1a}, t_{c1b} - Temperature of fluid entering condenser calorimeter, °F
- t_{c2a}, t_{c2b} - Temperature of fluid leaving condenser calorimeter, °F
- t_s - Local pipe refrigerant temperature, °F
- w_c - Mass flow rate of fluid through M1 entering the condenser calorimeter, lbm/h
- w_{v2} - Mass flow rate of subcooled refrigerant liquid through M2, lbm/h
- w_{v3} - Mass flow rate of subcooled refrigerant liquid through M3, lbm/h

C.10.3. Calculations

(Refer to Section [C.11](#) for calculated values)

- 1) Calculate system heat losses or gains, refer to [C.12.3.1](#).
- 2) Calculate the *recirculation ratio*, refer to [C.12.3.2](#).
- 3) Calculate the condenser calorimeter capacity, refer to [C.12.3.3.1](#).
- 4) Calculate the independent *gross total cooling effect: dry rating condition*, refer to [C.12.3.3.2](#).
- 5) Calculate the independent *gross total cooling effect: wet rating condition*, refer to [C.12.3.3.3](#).
- 6) Calculate the *gross total cooling effect* and heat balance, refer to [C.12.3.3.4](#) and [C.12.3.3.5](#).
- 7) Calculate the system heat loss or gain as a percent of the *gross total cooling effect*, refer to [C.12.3.3.6](#).

C.11. Calculated Values

Results from these calculations are required for Section [C.12](#).

C.11.1. Calculating Rated Power (All Methods)

C.11.1.1. Air Density for Rated Power Test

Determine the test air density (ρ_{test}) using dry-bulb temperature (T_{db}), barometric pressure (P_b) and wet-bulb temperature (T_{wb}) by referencing ASHRAE Psychrometric Analysis software.

C.11.1.2. Rated Power for Units with Single Phase

Use Equation 1 to calculate *rated power* for units with single phase.

$$p_{fmi} = \frac{(E)(\rho_{sa})}{\rho_{test}} \quad 1$$

C.11.1.3. Rated Power for Units with Polyphase Motors

Use Equation 2 to calculate *rated power* for units with polyphase motors.

$$p_{fmo} = \frac{(E)(e_{fm})(\rho_{sa})}{746(\rho_{test})} \quad 2$$

C.11.2. Average Measured Temperatures

C.11.2.1. Dry-bulb Temperature (All Methods)

Use Equation 3 to calculate dry-bulb temperature (using all methods).

$$T_{db} = \frac{\sum_1^n T_{dbn}}{n} \quad 3$$

C.11.2.2. Wet-bulb Temperature (All Methods)

Use Equation 4 to calculate wet-bulb temperature (using all methods).

$$T_{wb} = \frac{\sum_1^n T_{wb_n}}{n} \quad 4$$

C.11.2.3. Temperature of Subcooled Refrigerant Liquid Entering the Expansion Valve (Method 1)

Use Equation 5 to calculate the temperature of subcooled refrigerant liquid entering the expansion valve with method 1.

$$t_0 = \frac{t_{0a} + t_{0b}}{2} \quad 5$$

C.11.2.4. Temperature of Refrigerant Vapor Leaving the Unit Cooler (Method 1)

Use Equation 6 to calculate the temperature of refrigerant vapor leaving the unit cooler with method 1.

$$t_2 = \frac{t_{2a} + t_{2b}}{2} \quad 6$$

C.11.2.5. Temperature of Fluid Entering and Leaving Condenser Calorimeter (Method 3)

Use Equation 7 and Equation 8 to calculate the temperature of fluid entering and leaving the condenser calorimeter with method 3.

$$t_{c1} = \frac{t_{c1a} + t_{c1b}}{2} \quad 7$$

$$t_{c2} = \frac{t_{c2a} + t_{c2b}}{2} \quad 8$$

C.11.2.6. Temperature Controlled Enclosure Temperature (Method 2)

Use Equation 9 to calculate

$$T_{en} = \frac{\sum_1^n T_{en_n}}{n} \quad 9$$

C.11.2.7. Calibrated Box Temperature (Method 2)

Use Equation 10 to calculate calibrated box temperature (method 2).

$$T_{cb} = \frac{\sum_1^n T_{cb_n}}{n} \quad 10$$

C.11.3. Average Measured Pressures

C.11.3.1. Pressure of Subcooled Refrigerant Liquid Entering the Expansion Valve (Method 1)

Use Equation 11 to calculate pressure of subcooled refrigerant liquid entering the expansion valve (method 1).

$$P_0 = \frac{P_{0a} + P_{0b}}{2} \quad 11$$

C.11.3.2. Pressure of Refrigerant Vapor Leaving the Unit Cooler (Method 1)

Use Equation 12 to calculate pressure of refrigerant vapor leaving the unit cooler (method 1).

$$P_2 = \frac{P_{2a} + P_{2b}}{2} \quad 12$$

C.11.4. Calculated Saturation Temperatures

C.11.4.1. Refrigerant Liquid Saturation Temperature Entering the Expansion Valve (All Methods)

Determine t_{0s} for P_0 by referencing thermophysical properties in texts from ASHRAE Handbook Fundamentals or NIST REFPROP.

C.11.4.2. Unit Cooler Outlet Saturation Temperature (Methods 1 and 2)

Determine t_{2s} for P_2 by referencing thermophysical properties in texts from ASHRAE Handbook Fundamentals or NIST REFPROP.

C.11.4.3. Unit Cooler Outlet Saturation Temperature (Method 3) for Comparison to Measured t_3

Determine t_{3s} for P_3 by referencing thermophysical properties in texts from ASHRAE Handbook Fundamentals or NIST REFPROP.

C.11.4.4. Liquid/Vapor Separator Saturation Temperature (Method 3)

Determine t_{4s} for P_4 by referencing thermophysical properties in texts from ASHRAE Handbook Fundamentals or NIST REFPROP.

C.11.4.5. Condenser Calorimeter Saturation Temperature (Method 3)

Determine t_{5s} for P_5 by referencing thermophysical properties in texts from ASHRAE Handbook Fundamentals or NIST REFPROP.

C.11.5. Liquid Subcooling Entering Expansion Valve (All Methods)

Use Equation 13 to calculate liquid subcooling entering the expansion valve (using all methods).

$$t_{0sc} = t_{0s} - t_0 \quad 13$$

C.11.6. Vapor Superheat Leaving Unit Cooler (Methods 1 and 2)

Use Equation 14 to calculate vapor superheat leaving the unit cooler using methods 1 and 2.

$$t_{2sh} = t_2 - t_{2s} \quad 14$$

C.11.7. Enthalpies

C.11.7.1. Air Enthalpies (Methods 1 and 3)

Determine enthalpies using dry-bulb (T_{db}), barometric pressure (P_b) and wet-bulb (T_{wb}) by referencing ASHRAE Psychrometric Analysis software.

C.11.7.2. Refrigerant Enthalpies

Determine enthalpies for the appropriate refrigerant by using average pressure and temperature measured at each location and referencing thermodynamic software or texts from ASHRAE Handbook Fundamentals or NIST REFPROP.

C.11.8. TD Correction Factor

Use Equation 15 through Equation 17 to calculate the *TD* correction factor. Equation 15 uses methods 1 and 2. Equation 16 uses method 3.

$$TD_{test} = T_{db} - t_{2s} \quad 15$$

$$TD_{test} = T_{db} - t_{2s} \quad 16$$

$$TD_{CF} = \left(\frac{TD_{rated}}{TD_{test}} \right) \quad 17$$

Refer to Table 1 for TD_{rated} values.

C.11.9. Air Enthalpy Correction Factor (Methods 1 and 3)

Use Equation 18 through Equation 20 to calculate the air enthalpy correction factor with methods 1 and 3.

$$HD_{rated} = h_{a1} - h_{ar} \quad 18$$

$$HD_{test} = h_{a2} - h_{at} \quad 19$$

$$HD_{CF} = \left(\frac{HD_{rated}}{HD_{test}} \right) \quad 20$$

C.12. Capacity Calculations for Each Method

C.12.1. Gross Total Cooling Effect (Method 1)

C.12.1.1. Independent Measurement Gross Total Cooling Effect: Dry Rating Condition

Use Equation 21 and Equation 22 to calculate the independent measurement *gross total cooling effect* for *dry rating condition* with method 1.

$$q_{tr1} = w_{v1}(h_2 - h_0)(TD_{CF}) \quad 21$$

$$q_{tr2} = w_{v2}(h_2 - h_0)(TD_{CF}) \quad 22$$

C.12.1.2. Independent Measurement Gross Total Cooling Effect: Wet Rating Condition

Use Equation 23 and Equation 24 to calculate the independent measurement *gross total cooling effect* for *wet rating conditions* with method 1.

$$q_{tr1} = w_{v1}(h_2 - h_0)(HD_{CF}) \quad 23$$

$$q_{tr2} = w_{v2}(h_2 - h_0)(HD_{CF}) \quad 24$$

C.12.1.3. Gross Total Cooling Effect

Use Equation 25 to calculate the *gross total cooling effect* with method 1.

$$q_t = \frac{q_{tr1} + q_{tr2}}{2} \quad 25$$

C.12.1.4. Allowable Cooling Capacity Heat Balance

Use Equation 26 to calculate the allowable *cooling capacity* heat balance with method 1.

$$+5\% \geq \frac{100(q_{tr1} - q_{tr2})}{q_t} \geq -5\% \quad 26$$

C.12.2. Gross Total Cooling Effect – Dry Rating Condition Only (Method 2)

C.12.2.1. Heat Leakage Coefficient of Calibrated Box

Use Equation 27 to calculate the heat leakage coefficient of the calibrated box with method 2.

$$K_{cb} = 3.41 \frac{E_c}{(T_{en} - T_{cb})} \quad 27$$

C.12.2.2. Air-side Gross Total Cooling Effect

Use Equation 28 to calculate the air-side *gross total cooling effect* with method 2.

$$q_{ta} = [K_{cb}(T_{en} - T_{cb}) + 3.41(E_c + E)](TD_{CF}) \quad 28$$

C.12.2.3. Refrigerant-side Gross Total Cooling Effect

Use Equation 29 to calculate the refrigerant -side *gross total cooling effect* with method 2.

$$q_{tr} = w_{v1}(h_2 - h_0)(TD_{CF}) \quad 29$$

C.12.2.4. Gross Total Cooling Effect

Use Equation 30 to calculate the *gross total cooling effect* with method 2.

$$q_t = \frac{q_{ta} + q_{tr}}{2} \quad 30$$

C.12.2.5. Allowable Cooling Capacity Heat Balance

Use Equation 31 to calculate the allowable *cooling capacity* heat balance with method 2.

$$+5\% \geq \frac{100(q_{ta} - q_{tr})}{q_t} \geq -5\% \quad 31$$

C.12.3. Gross Total Cooling Effect Calculation. (Method 3)

C.12.3.1. System Heat Loss or Gain

C.12.3.1.1. Condenser Heat Loss or Gain

Use Equation 32 to calculate the condenser heat loss or gain with method 3.

$$q_{c1} = A_c k_c \left[T_{a1} - \frac{t_{5s} + t_6}{2} \right] \quad 32$$

C.12.3.1.2. Liquid/Vapor Separator Heat Loss or Gain

Use Equation 33 to calculate liquid/vapor separator heat loss with method 3.

$$q_s = A_s k_s (T_{a2} - t_{4s}) \quad 33$$

C.12.3.1.3. Piping Heat Loss or Gain

Use Equation 34 to calculate piping heat loss or gain with method 3.

$$q_p = \sum_1^n A_{p_n} k_{p_n} (T_{a_n} - t_{s_n}) \quad 34$$

C.12.3.1.4. Pump Heat Gain

Use Equation 35 and Equation 36 to calculate pump heat gain with method 3.

$$q_{cp} = w_{v2} (h_7 - h_6) \quad 35$$

$$q_{rp} = w_{v3} (h_9 - h_8) \quad 36$$

C.12.3.1.5. Heat Exchanger Heat Loss or Gain.

Use Equation 37 to calculate heat exchanger heat loss or gain with method 3.

$$q_{he} = w_{v3} (h_0 - h_9) \quad 37$$

C.12.3.2. Recirculation Ratio

Use Equation 38 to calculate the *recirculation ratio* with method 3.

$$RR = \left(\frac{w_{v3}}{w_{v2}} \right) \quad 38$$

C.12.3.3. Gross Total Cooling Effect

C.12.3.3.1. Condenser Calorimeter Capacity

Use Equation 39 through Equation 41 to calculate the condenser calorimeter capacity with method 3.

$$q_c = w_c (h_{c2} - h_{c1}) \quad 39$$

$$q_v = w_{v2} (h_5 - h_6) + q_{c1} \quad 40$$

$$w_{cc} = \frac{w_{v2} (h_5 - h_6) + q_{cl}}{(h_{c2} - h_{c1})} \quad 41$$

C.12.3.3.2. Independent Gross Total Cooling Effect: Dry Rating Condition

Use Equation 42 and Equation 43 to calculate the independent *gross total cooling effect* for *dry rating conditions* with method 3.

$$q_{tr1} = [w_c (h_{c2} - h_{c1}) - (q_{cp} + q_{rp} + q_{he})] (TD_{CF}) - (q_p + q_s) \quad 42$$

$$q_{tr2} = [w_{cc} (h_{c2} - h_{c1}) - (q_{cp} + q_{rp} + q_{he})] (TD_{CF}) - (q_p + q_s) \quad 43$$

C.12.3.3.3. Independent Gross Total Cooling Effect: Wet Rating Condition

Use Equation 44 and Equation 45 to calculate independent *gross total cooling effect* in *wet rating conditions* with method 3.

$$q_{tr1} = [w_c(h_{c2} - h_{c1}) - (q_{cp} + q_{rp} + q_{he})](HD_{CF}) - (q_p + q_s) \quad 44$$

$$q_{tr2} = [w_{cc}(h_{c2} - h_{c1}) - (q_{cp} + q_{rp} + q_{he})](HD_{CF}) - (q_p + q_s) \quad 45$$

C.12.3.3.4. Gross Total Cooling Effect

Use Equation 46 to calculate *gross total cooling effect* with method 3.

$$q_t = \frac{q_{tr1} + q_{tr2}}{2} \quad 46$$

C.12.3.3.5. Allowable Cooling Capacity Heat Balance

Use Equation 47 to calculate allowable *cooling capacity* heating balance with method 3.

$$+5\% \geq \frac{100(q_{tr1} - q_{tr2})}{q_t} \geq -5\% \quad 47$$

C.12.3.3.6. Allowable System Heat Loss or Gain

Use Equation 48 to calculate the allowable system heat loss or gain with method 3.

$$+5\% \geq \frac{100(q_{cl} + q_s + q_p)}{q_t} \geq -5\% \quad 48$$

C.13. Symbols and Subscripts

- A_c - Surface area of exposed external area of the condenser calorimeter, ft²
- A_p - Pipe surface area, ft²
- A_s - Liquid/vapor separator surface area, ft²
- E - Total electrical power input to fan motor(s) of *unit cooler*, W
- E_c - Total electrical power input to heater and auxiliary equipment, W
- e_{fm} - Fan motor efficiency
- FS - Fan speed (s), rpm
- h₀ - Enthalpy of refrigerant liquid entering the *unit cooler*, Btu/lb
- h₂ - Enthalpy of refrigerant leaving the *unit cooler*, Btu/lb
- h₅ - Enthalpy of refrigerant vapor entering the condenser, Btu/lb
- h₆ - Enthalpy of refrigerant liquid leaving condenser calorimeter and entering condensate pump, Btu/lb
- h₇ - Enthalpy of refrigerant liquid leaving the condensate pump, Btu/lb
- h₈ - Enthalpy of refrigerant liquid leaving the liquid/vapor separator, Btu/lb
- h₉ - Enthalpy of refrigerant liquid leaving the recirculation pump, Btu/lb
- h_{a1} - Enthalpy of the air entering the *unit cooler* at *standard rating conditions*, Btu/lb
- h_{a2} - Enthalpy of the air entering the *unit cooler* at the test condition, Btu/lb
- h_{ar} - Enthalpy of saturated air at *standard rating refrigerant saturation temperature*, Btu/lb
- h_{at} - Enthalpy of saturated air at the test *refrigerant saturation temperature*, Btu/lb
- h_{c1} - Enthalpy of fluid entering the condenser, Btu/lb

h_{c2}	-	Enthalpy of fluid leaving the condenser, Btu/lb
HD_{CF}	-	Enthalpy of air correction factor
HD_{rated}	-	<i>Enthalpy difference</i> of air at <i>rating conditions</i> , Btu/lb
HD_{test}	-	<i>Enthalpy difference</i> of air at test conditions, Btu/lb
k_c	-	Conductance of condenser calorimeter insulation, Btu/(h·°F·ft ²)
K_{cb}	-	Heat leakage coefficient of calibrated box, Btu/(h·°F)
k_p	-	Conductance of piping insulation, Btu/(h·°F·ft ²)
k_s	-	Conductance of liquid/vapor separator insulation, Btu/(h·°F·ft ²)
n	-	Number of measurement stations
N	-	Number of motors
P_0	-	Pressure of subcooled refrigerant liquid entering the expansion valve (method 1 average value), psi
P_{0a}	-	Pressure of subcooled refrigerant liquid entering the expansion valve, psi
P_{0b}	-	Pressure of subcooled refrigerant liquid entering the expansion valve, psi
P_2	-	Pressure of superheated refrigerant vapor leaving the <i>unit cooler</i> (method 1 average value), psi
P_{2a}	-	Pressure of superheated refrigerant vapor leaving the <i>unit cooler</i> , psi
P_{2b}	-	Pressure of superheated refrigerant vapor leaving the <i>unit cooler</i> , psi
P_3	-	Pressure of saturated refrigerant liquid/vapor mixture leaving the <i>unit cooler</i> , psi
P_4	-	Pressure of refrigerant in liquid/vapor separator, psi
P_5	-	Pressure of refrigerant entering condenser calorimeter, psi
P_6	-	Pressure of subcooled refrigerant liquid leaving condenser calorimeter and entering condensate pump, psi
P_7	-	Pressure of subcooled refrigerant liquid leaving condensate pump, psi
P_8	-	Pressure of subcooled refrigerant liquid entering recirculation pump, psi
P_9	-	Pressure of subcooled refrigerant liquid leaving recirculation pump, psi
P_b	-	Barometric pressure, in Hg
P_{c1}	-	Pressure of fluid entering condenser calorimeter, psi
P_{c2}	-	Pressure of fluid leaving condenser calorimeter, psi
p_{fmi}	-	Input <i>rated power</i> , W
p_{fmo}	-	Output <i>rated power</i> , hp
q_c	-	Capacity of the condenser calorimeter calculated from the non-volatile side, Btu/h
q_{cl}	-	Heat gain or loss to condenser calorimeter, Btu/h
q_{cp}	-	Heat gain from condensate pump, Btu/h
q_p	-	Total piping heat loss or gain, Btu/h
q_{rp}	-	Heat gain from recirculation pump, Btu/h
q_s	-	Heat gain or loss from liquid/vapor separator, Btu/h
q_t	-	<i>Gross total cooling effect</i> , Btu/h
q_{ta}	-	<i>Air-side gross total cooling effect</i> , Btu/h
q_{tr}	-	<i>Refrigerant-side gross total cooling effect</i> , Btu/h
q_{tr1}	-	<i>Refrigerant-side gross total cooling effect</i> established by first independent measurement, Btu/h
q_{tr2}	-	<i>Refrigerant-side gross total cooling effect</i> established by second independent measurement, Btu/h
q_v	-	Capacity of the condenser calorimeter calculated from the volatile side, Btu/h
q_{he}	-	Heat exchanger heat loss or gain, Btu/h

rh	-	Air inlet relative humidity, %
RR	-	<i>Recirculation ratio</i>
t ₀	-	Temperature of subcooled refrigerant liquid entering the expansion valve (method 1 average value), °F
t _{0a}	-	Temperature of subcooled refrigerant liquid entering the expansion valve, °F
t _{0b}	-	Temperature of subcooled refrigerant liquid entering the expansion valve, °F
t _{0s}	-	Temperature of saturated refrigerant entering the expansion valve, °F
t _{0sc}	-	Subcooling entering the expansion valve, °F
t ₂	-	Temperature of superheated refrigerant vapor leaving the <i>unit cooler</i> (method 1 average value), °F
t _{2a}	-	Temperature of superheated refrigerant vapor leaving the <i>unit cooler</i> , °F
t _{2b}	-	Temperature of superheated refrigerant vapor leaving the <i>unit cooler</i> , °F
t _{2s}	-	Temperature of saturated refrigerant leaving <i>unit cooler</i> , °F
t _{2sh}	-	Amount of superheat leaving <i>unit cooler</i> , °F
t ₃	-	Temperature of refrigerant liquid/vapor leaving the <i>unit cooler</i> , °F
t _{3s}	-	Temperature of saturated refrigerant leaving <i>unit cooler</i> , °F
t _{4s}	-	Temperature of saturated refrigerant in liquid/vapor separator, °F
t ₅	-	Temperature of refrigerant entering condenser calorimeter, °F
t _{5s}	-	Temperature of saturated refrigerant entering condenser calorimeter, °F
t ₆	-	Temperature of subcooled refrigerant liquid entering condensate pump, °F
t ₇	-	Temperature of subcooled refrigerant liquid leaving condensate pump, °F
t ₈	-	Temperature of subcooled refrigerant liquid entering recirculation pump, °F
t ₉	-	Temperature of subcooled refrigerant liquid leaving recirculation pump, °F
T _a	-	Local pipe ambient temperature, °F
T _{a1}	-	Condenser calorimeter ambient temperature, °F
T _{a2}	-	Liquid/vapor separator ambient temperature, °F
t _{c1}	-	Average temperature of fluid entering condenser calorimeter, °F
t _{c1a}	-	Temperature of fluid entering condenser calorimeter, °F
t _{c1b}	-	Temperature of fluid entering condenser calorimeter, °F
t _{c2}	-	Average temperature of fluid leaving condenser calorimeter, °F
t _{c2a}	-	Temperature of fluid leaving condenser calorimeter, °F
t _{c2b}	-	Temperature of fluid leaving condenser calorimeter, °F
T _{cb}	-	Average dry-bulb temperature of air within the calibrated box, °F
T _{db}	-	Average dry-bulb temperature of air entering <i>unit cooler</i> , °F
T _{dp}	-	<i>Dew point</i> temperature of air entering <i>unit cooler</i> , °F
T _{en}	-	Average dry-bulb temperature of air within the temperature controlled enclosure, °F
t _s	-	Local pipe refrigerant temperature, °F
T _{wb}	-	Wet-bulb temperature of air entering <i>unit cooler</i> , °F
TD _{CF}	-	<i>Temperature difference</i> correction factor
TD _{rated}	-	<i>Temperature difference</i> at rating conditions, °F
TD _{test}	-	<i>Temperature difference</i> at test conditions, °F
V	-	Voltage of each phase, V
w _c	-	Mass flow rate of fluid through M1 entering the condenser calorimeter, lbm/h
w _{cc}	-	Calculated mass flow rate of fluid through M1 entering the condenser calorimeter, lbm/h

- w_{v1} - Mass flow rate of subcooled refrigerant liquid through M1, lbm/h
- w_{v2} - Mass flow rate of subcooled liquid or superheated refrigerant vapor through M2 or M2ALT, lbm/h
- w_{v3} - Mass flow rate of subcooled refrigerant liquid through M3, lbm/h

Greek Symbols

- ρ_{sa} - Density of air at *standard air conditions*, 0.075 lb/ft³
- ρ_{test} - Density of air at test conditions, lb/ft³

Conversion factors

- 1 hp = 746 W
- 1 W = 3.41 Btu/h

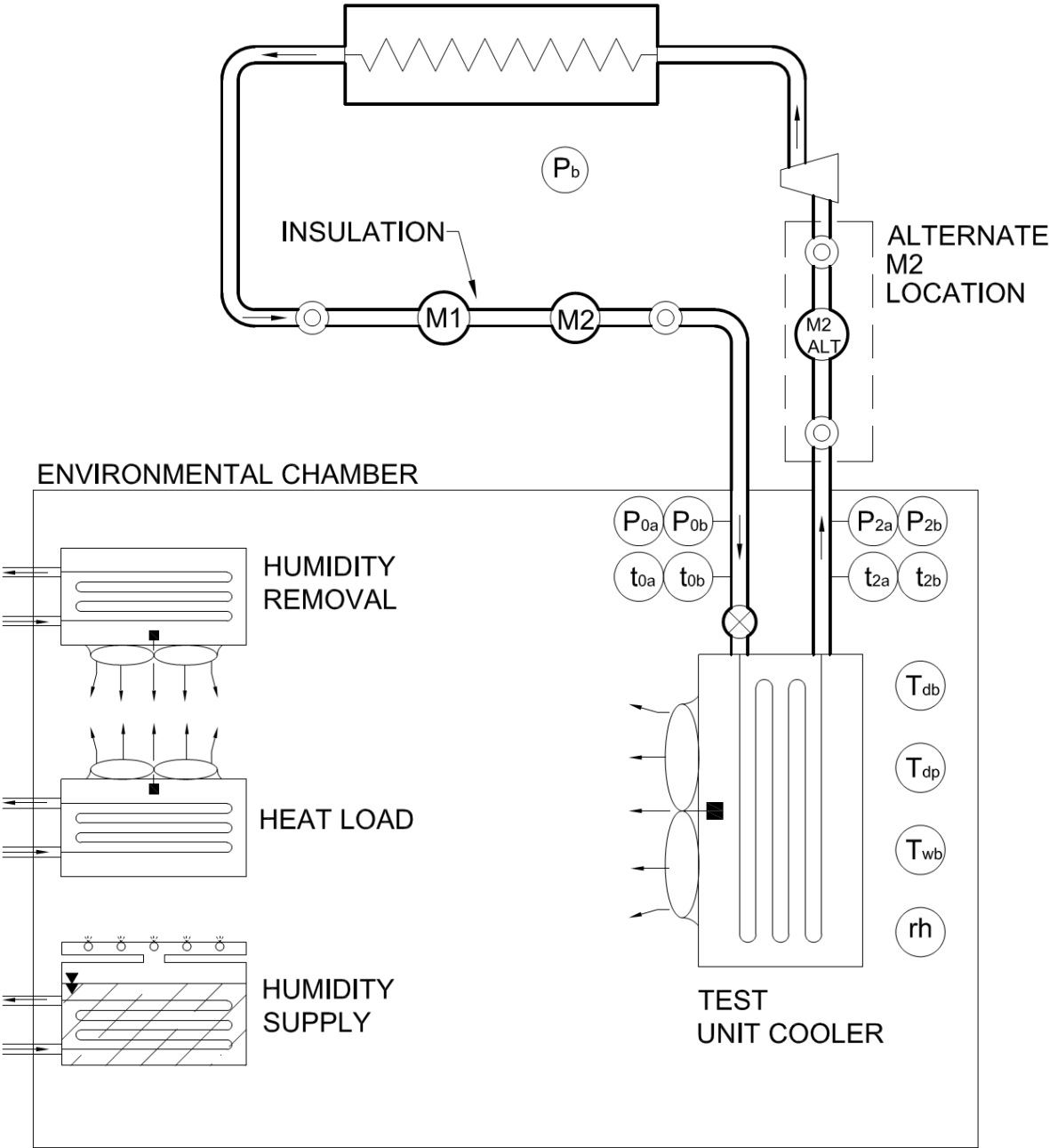

LEGEND			
	Vapor Compressor		Pressure measurement station
	Mass flow meter		Air temperature measurement station
	Expansion valve		Refrigerant temperature measurement station
	Sight Glass		Air inlet relative humidity
	Insulation Required		Barometric pressure

Figure 1 Method 1: DX – Dual Instrumentation

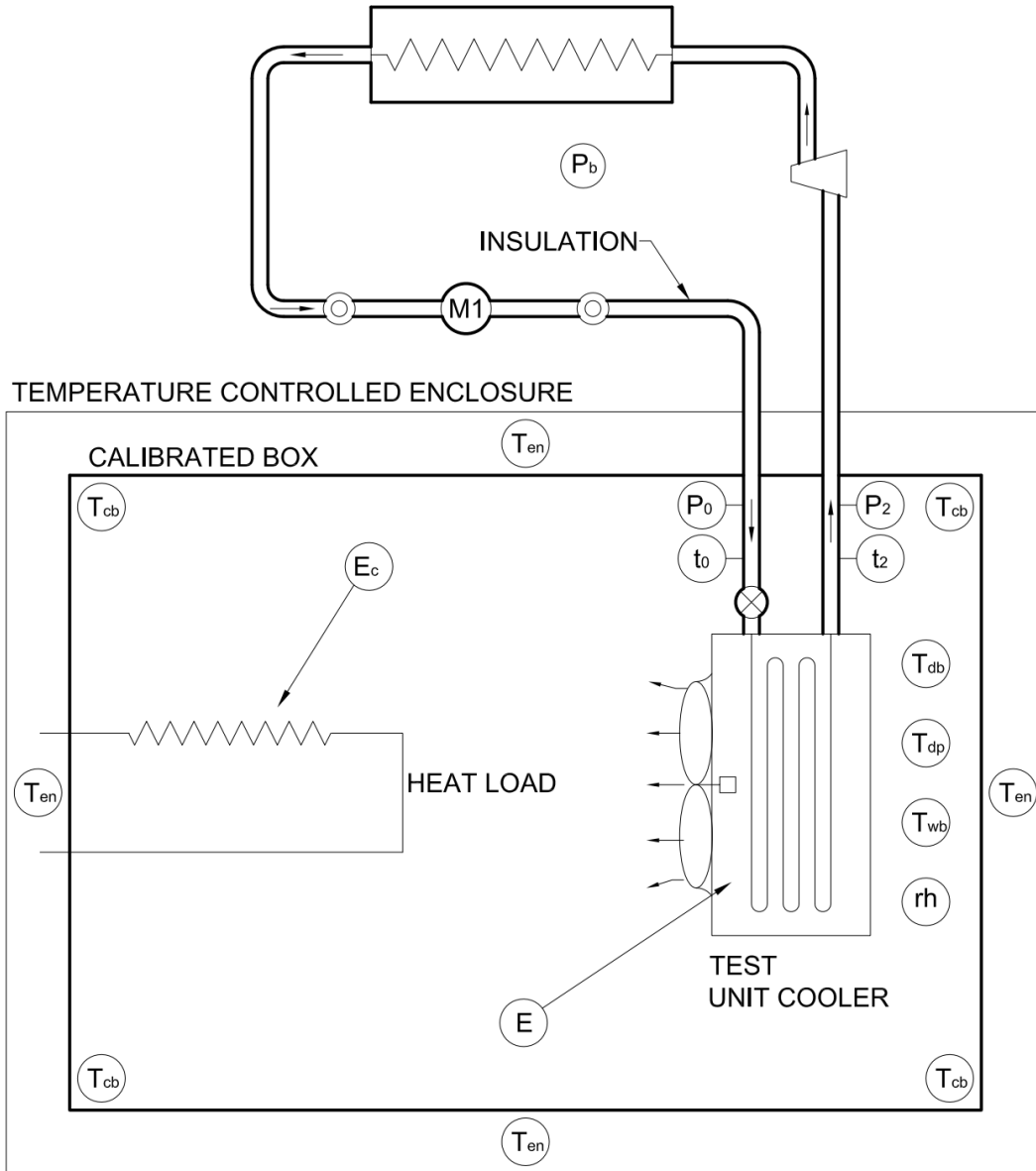

LEGEND			
	Vapor Compressor		Pressure measurement station
	Mass flow meter		Air temperature measurement station
	Expansion valve		Refrigerant temperature measurement station
	Sight Glass		Air inlet relative humidity
	Insulation Required		Barometric pressure
			Fan Power
			Heat load input power

Figure 2 Method 2: DX – Calibrated Box

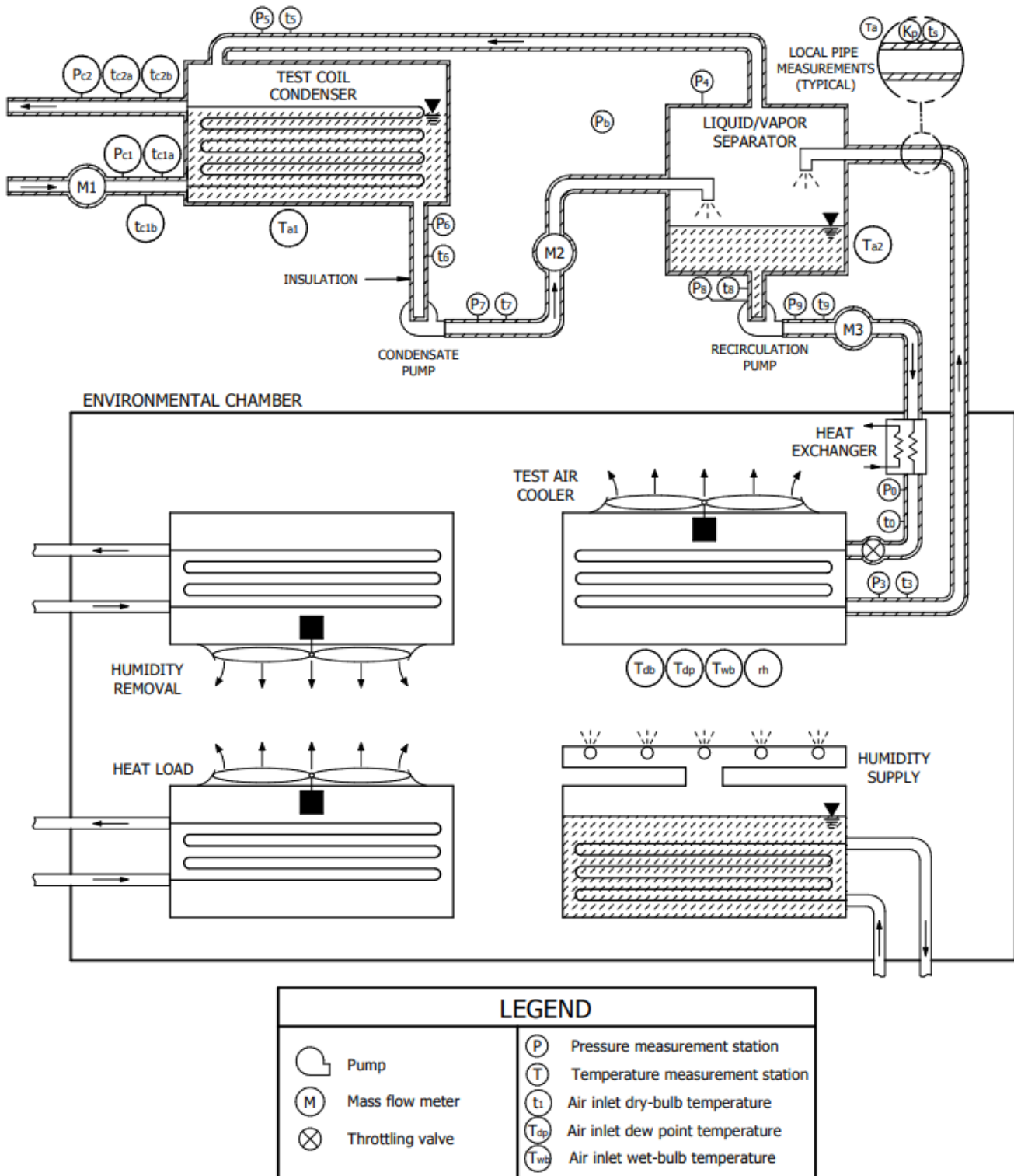

Figure 3 Method 3: Liquid Overfeed