

AHRI Standard 760-2014 (I-P)

2014 Standard for
**Performance Rating of
Solenoid Valves for Use with
Volatile Refrigerants**



we make life better®

2311 Wilson Boulevard, Suite 400
Arlington, VA 22201, USA
www.ahrinet.org
PH 703.524.8800
FX 703.562.1942

IMPORTANT

SAFETY DISCLAIMER

AHRI does not set safety standards and does not certify or guarantee the safety of any products, components or systems designed, tested, rated, installed or operated in accordance with this standard/guideline. It is strongly recommended that products be designed, constructed, assembled, installed and operated in accordance with nationally recognized safety standards and code requirements appropriate for products covered by this standard/guideline.

AHRI uses its best efforts to develop standards/guidelines employing state-of-the-art and accepted industry practices. AHRI does not certify or guarantee that any tests conducted under the standards/guidelines will not be non-hazardous or free from risk.

ICS Code: 27.200

Note:

This standard supersedes AHRI Standard 760-2007.
For SI ratings, see AHRI Standard 761-2014 (SI).

Approved as an American National Standard (ANS) on 15 May 2015.
AHRI Administratively withdrew support of ANS on 17 May 2023.

TABLE OF CONTENTS

SECTION	PAGE
Section 1. Purpose	1
Section 2. Scope	1
Section 3. Definitions	1
Section 4. Test Requirements	2
Section 5. Rating Requirements	2
Section 6. Minimum Data Requirements for Published Ratings.....	4
Section 7. Marking and Nameplate Data.....	4
Section 8. Conformance Conditions.....	4

TABLES

Table 1. Standard Rating Conditions.....	2
Table 2. Published Application Ratings for Discharge Gas Service	4

APPENDICES

Appendix A. References - Normative	5
Appendix B. References - Informative	5
Appendix C. Method of Testing for Rating Solenoid Valves for Maximum Operating Pressure Differential (MOPD) - Normative	6
Appendix D. Recommended Standard Connection Sizes - Informative.....	13

TABLES FOR APPENDICES

Table C1. Pressure-tap Hole Diameters and Lengths	8
Table D1. Recommended Standard Connection Sizes	13

FIGURES FOR APPENDICES

Figure C1.	Typical System Piping for Solenoid Valve MOPD Test with Gas or Liquid	7
Figure C2.	Typical Electrical Test Apparatus for an Alternating Current Solenoid Valve.....	9
Figure C3.	Typical Electrical Test Apparatus for a Direct Current Solenoid Valve.....	10

PERFORMANCE RATING OF SOLENOID VALVES FOR USE WITH VOLATILE REFRIGERANTS

Section 1. Purpose

1.1 *Purpose.* The purpose of this standard is to establish for Solenoid Valves for use with volatile refrigerants: definitions; test requirements; rating requirements; minimum data requirements for Published Ratings; marking and nameplate data; and conformance conditions.

1.1.1 *Intent.* This standard is intended for the guidance of the industry, including manufacturers, engineers, installers, contractors and users.

1.1.2 *Review and Amendment.* This standard is subject to review and amendment as technology advances.

Section 2. Scope

2.1 *Scope.* This standard applies to Solenoid Valves for use with volatile refrigerants as defined in Section 3.

Section 3. Definitions

All terms in this document follow the standard industry definitions in the *ASHRAE Terminology* website (<https://www.ashrae.org/resources--publications/free-resources/ashrae-terminology>) unless otherwise defined in this section.

3.1 *Bubble Point.* Refrigerant liquid saturation temperature at a specified pressure.

3.2 *Dew Point.* Refrigerant vapor saturation temperature at a specified pressure.

3.3 *Main.* Tubing or piping by which the Solenoid Valve is connected to the apparatus.

3.4 *Maximum Operating Pressure Differential (MOPD).* The maximum pressure difference between the solenoid valve inlet and the solenoid valve outlet at which the Solenoid Valve will operate, psi.

3.5 *Pressure Drop.* The pressure difference between the solenoid valve inlet and the solenoid valve outlet with the main port (orifice) open, psi.

3.6 *Published Rating.* A statement of the assigned values of those performance characteristics, under stated Rating Conditions, by which a unit may be chosen to fit its application. These values apply to all units of like nominal size and type (identification) produced by the same manufacturer. The term Published Rating includes the rating of all performance characteristics shown on the unit or published in specifications, advertising or other literature controlled by the manufacturer, at stated Rating Conditions.

3.6.1 *Application Rating.* A rating based on tests performed at application Rating Conditions (other than Standard Rating Conditions).

3.6.2 *Standard Rating.* A rating based on tests performed at Standard Rating Conditions.

3.7 *Rating Conditions.* Any set of operating conditions under which a single level of performance results and which causes only that level of performance to occur.

3.7.1 *Standard Rating Conditions.* Rating Conditions used as the basis of comparison for performance characteristics.

3.8 *"Shall" or "Should."* "Shall" or "should" shall be interpreted as follows:

3.8.1 *Shall.* Where "shall" or "shall not" is used for a provision specified, that provision is mandatory if compliance with the standard is claimed.

3.8.2 *Should.* "Should" is used to indicate provisions which are not mandatory but which are desirable as good practice.

3.9 *Solenoid Valve.* A valve which is actuated by the magnetic action of an electrically energized coil. The opposite action is accomplished by gravity, pressure or spring action.

3.9.1 *Direct-action Solenoid Valve.* A valve in which the magnetic power of an electrically energized coil moves the main port (orifice) closure member.

3.9.2 *Normally Closed Solenoid Valve.* A valve which is closed when de-energized. When the coil is electrically energized, the closure member is moved away from and off the port (orifice) to cause the opening action.

3.9.3 *Normally Open Solenoid Valve.* A valve which is open when de-energized. When the coil is electrically energized, the closure member is moved toward and onto the port (orifice) to cause the closing action.

3.9.4 *Pilot-operated Solenoid Valve.* A valve in which the motion of a direct-acting member allows a pressure difference to occur across the main port (orifice) closure member, causing it to move.

3.10 *Solenoid Valve Capacity.* The mass flow rate of a fluid through the Solenoid Valve, equated to tons of refrigeration at the specified conditions.

3.11 *Volatile Refrigerants.* A refrigerant that changes from the liquid to the vapor state in the process of absorbing heat.

Section 4. Test Requirements

4.1 *Capacity Tests.* All capacity tests shall be in accordance with the test procedure defined in ANSI/ASHRAE Standard 158.1.

4.2 *MOPD Tests.* All MOPD tests shall be in accordance with the test procedure in Appendix C.

4.2.1 If the Solenoid Valve MOPD depends on the valve position, the valve shall be tested in all positions for which the ratings apply.

Section 5. Rating Requirements

5.1 *Rating Requirements.* Published capacity ratings shall consist of Standard Ratings and may include Application Ratings. The AHRI Standard Ratings of Solenoid Valve Capacity for Volatile Refrigerants shall be stated in tons of refrigeration and at the conditions specified in Table 1.

5.2 *Standard Rating Conditions.* Standard ratings shall be for liquid service applications of solenoid valves per Table 1.

5.2.1 *Liquid Service Solenoid Valve Entrance Conditions.*

Table 1. Standard Rating Conditions	
Liquid Service Solenoid Valve Rating Condition	
Saturated Condenser (Dew Point) Temperature, °F	110.0
Liquid Service Temperature Entering the Valve, °F	100.0
Saturated Evaporating (Bubble Point) Temperature, °F	40.0

5.2.2 Pressure Drop Values.

5.2.2.1 Liquid Service. The Pressure Drop across the Solenoid Valve shall be the closest integer value in psi equivalent to a 1.0°F drop in saturation temperature.

5.2.3 In no case shall the Pressure Drop be less than required for proper operation of the Solenoid Valve.

5.2.4 The solenoid valve capacity ratings for refrigerant liquid service shall be based on the method described in Section C4.1.

5.2.5 Expansion Point Enthalpy (h_f). Enthalpy based on 100°F liquid refrigerant entering the liquid service Solenoid Valve.

5.2.6 Enthalpy of the Refrigerant Suction Gas (h_g). Enthalpy based on vapor at a dew point pressure corresponding to 40°F leaving the evaporator.

5.3 MOPD Ratings. MOPD ratings shall be obtained in accordance with Section 4.2 and Appendix C, and shall be stated in psi.

5.3.1 If the solenoid valve MOPD depends on the valve orientation, then it shall be rated for the orientation that results in the lowest MOPD pressure.

5.4 Application Ratings. Application Ratings give performance data at operating conditions other than those given above. Applications Ratings shall contain all information shown in Section 6.2. Published Ratings shall be subject to the tolerances of this standard.

5.4.1 Liquid Service.

5.4.1.1 In addition to AHRI standard capacity ratings at pressure drop values specified in Table 1, capacity ratings may also be given at other pressure drop values, provided that they are specified as such and based on all the other conditions given in Section 5.2.

5.4.2 Suction Service.

5.4.2.1 The Pressure Drop shall be 1.0 psi for all refrigerants unless the manufacturer's stated lowest pressure differential is greater than 1.0 psi for satisfactory operation.

5.4.2.2 Solenoid Valves requiring greater than 1.0 psi pressure differential shall show an AHRI Standard Rating at the manufacturer's stated lowest pressure differential required for satisfactory operation.

5.4.2.3 Enthalpy of the Refrigerant Suction Gas (h_g). Enthalpy based on vapor at a dew point pressure corresponding to 40°F leaving the evaporator.

5.4.3 Discharge Gas Service.

5.4.3.1 The Pressure Drop shall be 2.0 psi for all refrigerants.

5.4.3.2 Discharge Gas Temperature. The temperature that would result from isentropic compression from the saturated evaporator (Dew Point) temperature with 25.0°F superheat, to a saturated condensing (Bubble Point) temperature of 110°F with 50.0°F added as an approximation of the actual polytropic refrigerant compression process.

5.4.3.3 In addition to the Standard Rating at a 2.0 psi Pressure Drop, Application Ratings for discharge gas service may be published for the pressure drop values shown in Table 2 (for all refrigerants).

Table 2. Published Application Ratings for Discharge Gas Service	
Condition Number	Pressure Drop Values, psi
1	5.0
2	10.0
3	25.0
4	50.0
5	75.0
6	100

5.5 Tolerances. To comply with this standard, measured test results shall not be less than 95% of the published capacity rating.

Section 6. Minimum Data Requirements for Published Ratings

6.1 Minimum Data Requirements for Published Ratings. As a minimum, Published Ratings shall include all Standard Ratings. All claims to ratings within the scope of this standard shall include the statement “Rated in accordance with AHRI Standard 760 (I-P).” All claims to ratings outside the scope of this standard shall include the statement “Outside the scope of AHRI Standard 760 (I-P).” Wherever Applications Ratings are published or printed, they shall include a statement of the conditions at which the ratings apply.

6.2 Published Ratings. Published Ratings shall include the following information:

- 6.2.1** MOPD, psi (See Section 5.3.1, when MOPD varies with valve orientation)
- 6.2.2** Refrigerant designation(s) per ANSI/ASHRAE 34 with Addenda
- 6.2.3** AHRI standard capacity rating(s) including application (liquid/suction/discharge capacities)
- 6.2.4** Model designation
- 6.2.5** Line connections (size and type)
- 6.2.6** Electrical characteristics: voltage(s), V; frequency(s), Hz (if alternating current); and power, W
- 6.2.7** Manufacturer's name and address

Section 7. Marking and Nameplate Data

7.1 Marking and Nameplate Data. As a minimum, each Solenoid Valve shall be marked with the following information:

- 7.1.1** The manufacturer's name or trade name
- 7.1.2** Model designation
- 7.1.3** Electrical characteristics: voltage(s), V; frequency(s), Hz (if alternating current); and power, W
- 7.1.4** MOPD, psi (See Section 5.3.1, when MOPD varies with valve orientation)

Section 8. Conformance Conditions

8.1 Conformance. While conformance with this standard is voluntary, conformance shall not be claimed or implied for products or equipment within the standard’s *Purpose* (Section 1) and *Scope* (Section 2) unless such claims meet all of the requirements of the standard and all of the testing and rating requirements are measured and reported in complete compliance with the standard. Any product that has not met all the requirements of the standard shall not reference, state, or acknowledge the standard in any written, oral, or electronic communication.

APPENDIX A. REFERENCES - NORMATIVE

A1 Listed here are all standards, handbooks and other publications essential to the formation and implementation of the standards. All references in this appendix are considered as part of the standard.

A1.1 ANSI/ASHRAE Standard 34-2013, *Designation and Safety Classification of Refrigerants*, 2013, American National Standards Institute/American Society of Heating, Refrigerating and Air-Conditioning Engineers, Inc., 1791 Tullie Circle N.E., Atlanta, GA 30329, U.S.A.

A1.2 ANSI/ASHRAE Standard 41.1-2013, *Standard Method for Temperature Measurement*, 2013, American National Standards Institute/American Society of Heating, Refrigerating and Air-Conditioning Engineers, Inc., 1791 Tullie Circle N.E., Atlanta, GA 30329, U.S.A.

A1.3 ANSI/ASHRAE Standard 41.3-2014, *Standard Method for Pressure Measurement*, 2014, American National Standards Institute/American Society of Heating, Refrigerating and Air-Conditioning Engineers, Inc., 1791 Tullie Circle N.E., Atlanta, GA 30329, U.S.A.

A1.4 ANSI/ASHRAE Standard 158.1-2012, *Method of Testing Capacity of Refrigerant Solenoid Valves*, 2012, American National Standards Institute/American Society of Heating, Refrigerating and Air-Conditioning Engineers, Inc., 1791 Tullie Circle N.E., Atlanta, GA 30329, U.S.A.

A1.5 *ASHRAE Terminology*, <https://www.ashrae.org/resources--publications/free-resources/ashrae-terminology>, 2014, American Society of Heating, Refrigerating and Air-Conditioning Engineers, Inc., 1791 Tullie Circle N.E., Atlanta, GA 30329, U.S.A.

APPENDIX B. REFERENCES - INFORMATIVE

B1 Listed here are standards, handbooks and other publications, which may provide useful information and background but are not considered essential. References in this appendix are not considered part of the standard.

B1.1 *ASHRAE Handbook - Fundamentals*, 2013, American Society of Heating, Refrigerating and Air-Conditioning Engineers, Inc., 1791 Tullie Circle N.E., Atlanta, GA 30329, U.S.A.

B1.2 *ASHRAE Handbook - HVAC Systems and Equipment*, 2012, American Society of Heating, Refrigerating and Air-Conditioning Engineers, Inc., 1791 Tullie Circle N.E., Atlanta, GA 30329, U.S.A.

B1.3 *ASHRAE Refrigerant Line Sizing RP185*, 1977, American Society of Heating, Refrigerating and Air-Conditioning Engineers, Inc., 1791 Tullie Circle N.E., Atlanta, GA 30329, U.S.A.

B1.4 *ASME Fluid Meters. Their Theory and Application*, Sixth Edition, 1971, ASME International, Three Park Avenue, New York, NY 10016, U.S.A.

B1.5 *Flow Characteristics of Solenoid Valves - Report No. 3 – Final Report*, dated January 1970, a thesis submitted by George T. Kartsounes to the faculty of Purdue University, West Lafayette, IN 47907-1077.

APPENDIX C. METHOD OF TESTING FOR RATING SOLENOID VALVES FOR MAXIMUM OPERATING PRESSURE DIFFERENTIAL (MOPD) – NORMATIVE

C1 *Method of Test.*

C1.1 *MOPD Testing.*

C1.1.1 The Solenoid Valve shall be tested on a test loop with instrumentation in accordance with Section C2 and apparatus in accordance with Section C3.

C1.1.2 The tests shall be conducted in accordance with Section C4 and the data shall be recorded in accordance with Section C5.

C2 *Instruments.*

C2.1 *General.* Instruments shall have accuracy listed in this standard and shall be certified standard instruments.

C2.2 *Temperature Measuring Instruments.* All temperature-measuring instruments shall be calibrated in accordance with ANSI/ASHRAE Standard 41.1.

C2.3 *Pressure Measuring Instruments.* All pressure measuring instruments shall be calibrated in accordance with ANSI/ASHRAE Standard 41.3.

C2.4 *Fluid Flow Measuring Instruments.*

C2.4.1 All fluid flow measuring instruments shall be accurate within 2.0% of the reading, throughout the range of flows measured.

C2.4.2 In no case shall the smallest scale division of the measuring instrument exceed 2.5 times the specified accuracy.

C2.5 *Electrical Measuring Instruments.*

C2.5.1 The accuracy of all electrical measuring instruments shall be within the following tolerance limits.

C2.5.1.1 For voltage measuring instruments, the tolerance shall be $\pm 0.5\%$ of the voltage indicated by the voltmeter.

C2.5.1.2 For resistance measuring instruments, the tolerance limits shall be $\pm 1.0\%$ of the resistance indicated by the resistance bridge meter.

C2.5.1.3 For current measuring instruments, the tolerance limits shall be $\pm 1.0\%$ of the current indicated on the ammeter.

C2.5.2 In no case shall the smallest scale division of the measuring instrument exceed 2.0 times the specified accuracy.

C3 Apparatus.

C3.1 MOPD Tests.

C3.1.1 MOPD Test (Liquid). The Solenoid Valve to be tested shall be installed in a system such as the one shown in Figure C1, where water is supplied to the valve by a pressurized tank of adequate capacity through a suitable pressure regulating device. Other essential apparatus which shall be used are covered in Section C3.2.

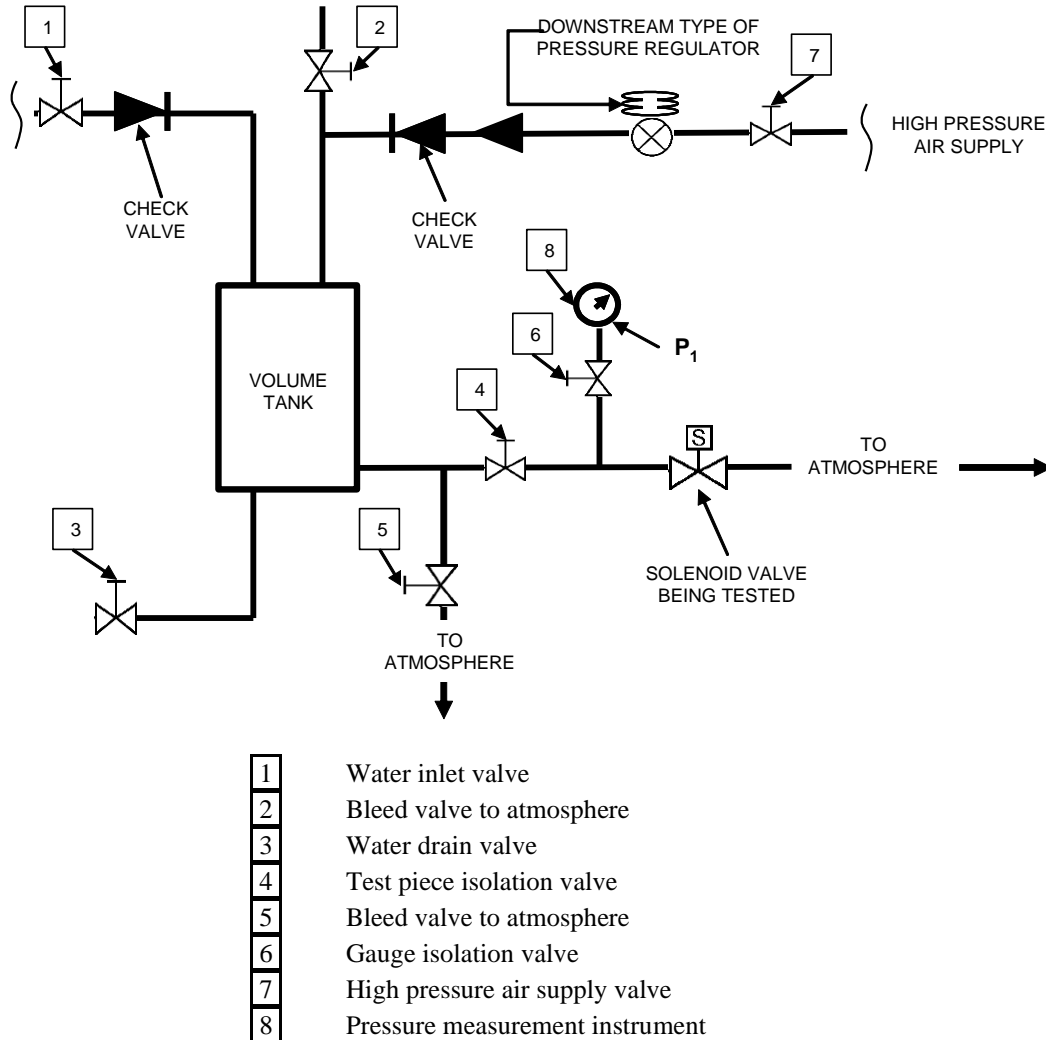

Figure C1. Typical System Piping for Solenoid Valve MOPD Test with Gas or Liquid

C3.1.2 MOPD Test (Gas). The Solenoid Valve to be tested shall be installed in a system such as the one shown in Figure C1 where air pressure from a regulated source is supplied. Other essential apparatus which shall be used are covered in Section C3.2.

C3.2 Other Essential Apparatus.

C3.2.1 Instrumentation. Suitable instrumentation shall be chosen for measuring temperature (Section C2.2), pressure (Section C2.3) and flow (Section C2.4).

C3.2.2 Main Size. The pipe or tubing used for the inlet and outlet connecting Mains to the Solenoid Valve being tested shall be Schedule 40 wrought iron or steel pipe, or Type L hard drawn copper tubing. The Main size shall be the same size and type provided by the Solenoid Valve body connections. In the case of solder

type body connections which are machined to be used with either of two sizes of tubing, the smaller size shall govern the Main size for test purposes. The Main shall be free from scale, rust or other obstructions which may cause excessive turbulence.

C3.2.3 Main Length. The inlet and outlet Mains connected to the Solenoid Valve being tested shall be straight for a minimum of fourteen internal Main diameters from the face of the Solenoid Valve inlet and outlet connections, respectively.

C3.2.4 Pressure-tap Holes.

C3.2.4.1 It is necessary to locate the pressure-tap holes at the proper points. With vertical Mains the points on the circumference of the Main at which the holes are drilled shall depend on the position of the Main with respect to adjacent surroundings. With horizontal Mains, the position of the holes on the circumference of the Main depends largely on the fluid being carried in the Main, and somewhat on the available clearance and the position of any bends preceding the holes.

With liquids, the pressure-tap holes shall be at or below the centerline of the Main and shall not be placed near the bottom if there is any possibility of their becoming clogged with sediment.

Extreme care shall be exercised in providing pressure-tap holes in the wall of the Main in order to avoid errors due to impact and eddies. The character of the Main adjoining the holes shall be such as to ensure that the flow is parallel to the wall. There shall be no rivet heads, jogs or other sources of eddies nearby.

The holes shall be drilled radial and perpendicular to the axis of the Main and should be on the same side with their axes parallel. The pressure-tap holes shall be straight, and of uniform size, for a length from the inner surface of the Main equal to at least two hole diameters. Additional material shall be affixed to the Main if the Main has a wall thickness less than two hole diameters. The inner rim of the hole shall be flush with the inner surface of the Main, shall have no burrs or jagged edges and shall be slightly rounded to make smoothness more certain.

Table C1 lists the pressure-tap hole diameters and lengths which shall be used in various sizes of Mains.

Table C1. Pressure-tap Hole Diameters and Lengths			
Main Type and Size		Pressure-tap Hole	
Nominal Pipe Size, in	Nominal Tube Size – OD, in	Diameter, in	Length from Internal Surface of the Main, in
1/8 - 1/4	3/16 - 3/8	1/32	1/16
3/8	1/2	3/64	3/32
1/2	5/8 - 3/4	1/16	1/8
3/4	7/8	5/64	5/32
1	1-1/8	3/32	3/16

C3.2.4.2 The upstream hole shall be located in the Main, two internal main diameters upstream from the face of the inlet connection of the Solenoid Valve being tested.

C3.2.4.3 The downstream hole shall be located in the Main, ten internal main diameters downstream from the face of the outlet connection of the Solenoid Valve being tested.

C3.2.5 Fluid Temperature Measurement Locations. Measurement of the fluid temperature entering the Solenoid Valve, when required, shall be made at a point located not over twelve internal Main diameters upstream from the face of the inlet connection of the Solenoid Valve being tested.

C3.2.6 Electrical Apparatus and Current Supply. The correct electric current source of adequate capacity shall be made available with a stabilized voltage ($\pm 1.0\%$ regulation for alternating and direct current, $\pm 1.0\%$

ripple for direct current; the alternating current supply shall be pure sine wave form voltage with total harmonic distortion of 5% maximum) which can be adjusted, using any necessary electrical apparatus, to provide the following:

C3.2.6.1 The rated solenoid valve coil voltage which is used to heat the solenoid valve coil to equilibrium temperature.

C3.2.6.2 A lower voltage, equal to 90% of the rated solenoid valve coil voltage, which is used to determine the MOPD of the Solenoid Valve. For DC Solenoid Valves, if preferred, a lower current equal to 90% of the current drawn at equilibrium temperature, which is used to determine the MOPD of DC Solenoid Valves.

When conducting the MOPD tests, it is advisable to impose an additional constant electrical load on the lines to which the solenoid valve coil is connected in order to avoid a dip in the voltage applied to the solenoid valve coil at the moment the coil is energized. Typical arrangements of electrical apparatus, required for alternating and direct current solenoid valve tests, are described in the following paragraphs.

C3.2.6.3 Alternating Current. Connect the input side of an adjustable autotransformer to a stabilized alternating current source having the correct voltage, frequency and adequate capacity. Connect the output side of the autotransformer to the solenoid valve coil with a voltmeter across the coil leads. By adjusting the autotransformer, the voltage applied to the solenoid valve coil can be changed to satisfy the specified conditions and test procedure. A resistance bridge meter is used to measure the DC resistance of the solenoid valve coil (Figure C2).

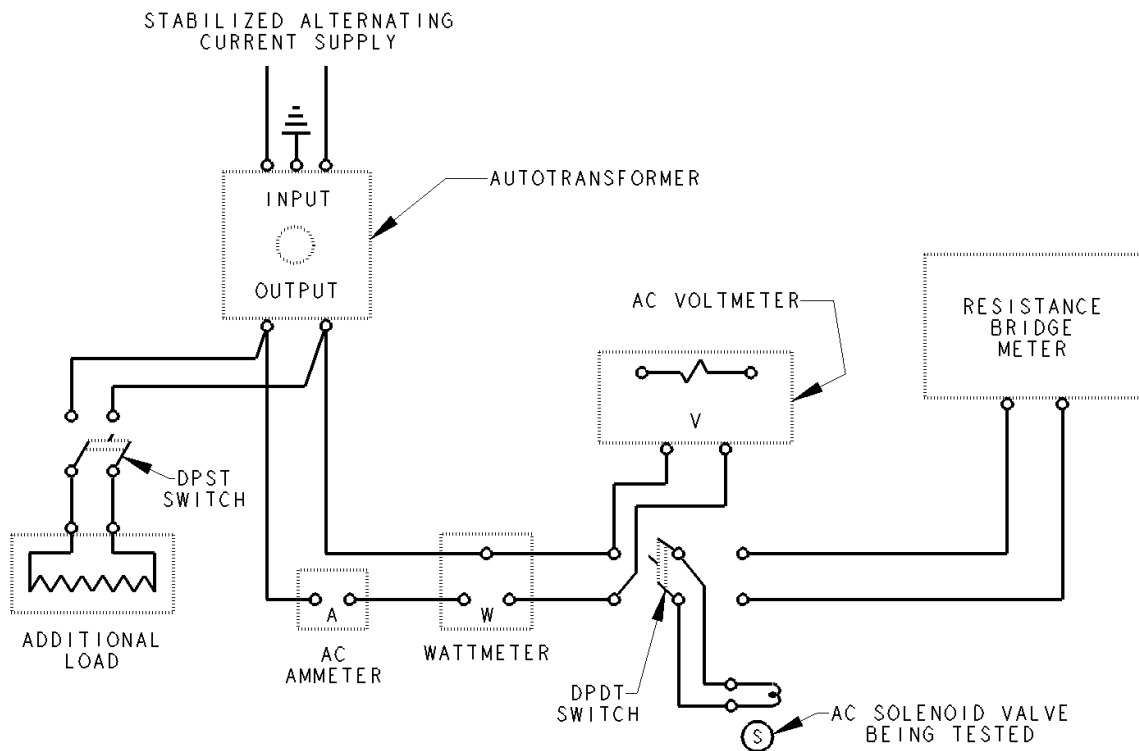

Figure C2. Typical Electrical Test Apparatus for an Alternating Current Solenoid Valve

C3.2.6.4 Direct Current. Connect the input side of an adjustable autotransformer to a stabilized alternating current source having the correct voltage, frequency and adequate capacity. Connect the output side of the autotransformer to the input side of a rectifier. Connect the output side of the

rectifier to the solenoid valve coil with the voltmeter across the coil leads and an ammeter in series with the coil. By adjusting the autotransformer which controls the input alternating current voltage to the rectifier, the output direct current voltage or current of the rectifier applied to the solenoid valve coil, can be changed to satisfy the specified conditions and test procedure. The resistance bridge meter is used to measure the DC resistance of the solenoid valve coil (Figure C3).

The combination of the autotransformer and the rectifier used for a source of direct current in Figure C3 can be replaced by one of the following

C3.2.6.4.1 A direct current generator having adequate capacity, a regulated voltage output and a means of adjustment to provide the specified test voltage requirements.

C3.2.6.4.2 One or more batteries of adequate capacity wired together in series and/or parallel, having one of the supply terminals connected between cells, when necessary, to provide the specified test voltage requirements.

An adjustable resistor placed in one of the lines, to which the Solenoid Valve is connected, will permit making small adjustments in the voltage to meet the specified test voltage requirements.

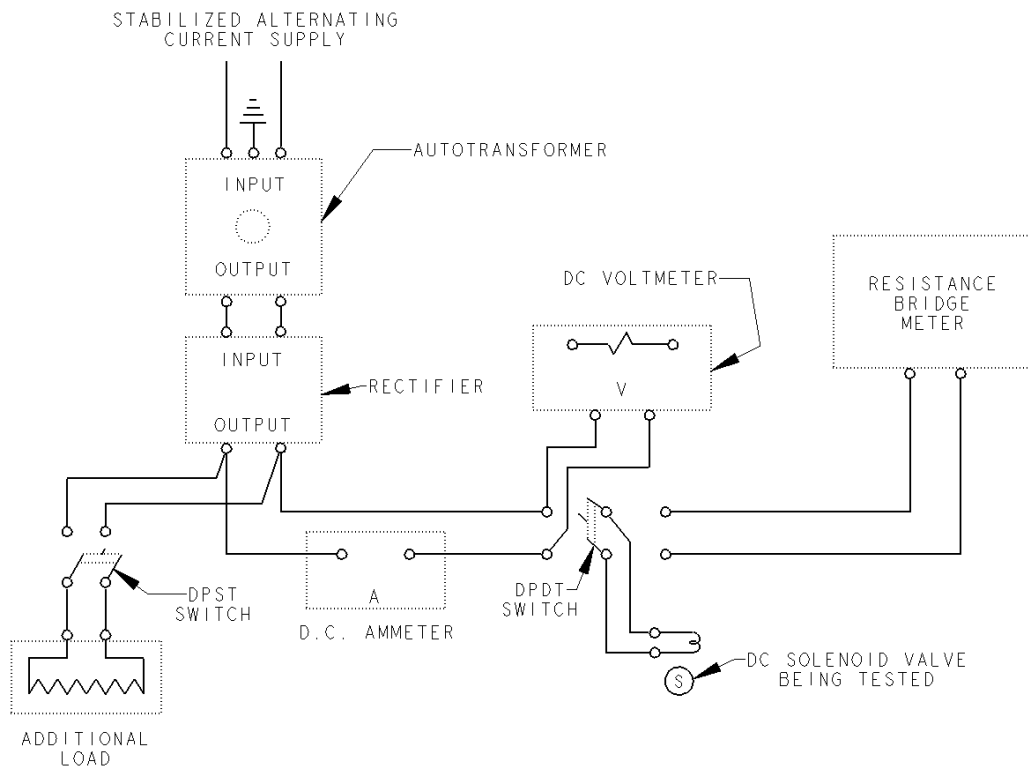

Figure C3. Typical Electrical Test Apparatus for a Direct Current Solenoid Valve

C4 Test Procedure.

C4.1 MOPD Test. The MOPD of the Solenoid Valve shall be determined in the following manner:

C4.1.1 The Solenoid Valve shall be tested on a system with instrumentation in accordance with Section C2 and apparatus in accordance with Section C3.2.

C4.1.2 The test shall consist of the following procedures:

C4.1.2.1 The Solenoid Valve shall be subjected to the required ambient temperature with a tolerance of $\pm 3.0^{\circ}\text{F}$. At the same time, the solenoid valve coil shall be energized at the rated coil voltage with a tolerance of $\pm 0.25\%$ thereby heating the coil until equilibrium temperature (maximum attained temperature) in the coil is reached as determined by the DC resistance method of measurement.

Equilibrium temperature (maximum attained temperature) in the solenoid valve coil is reached when the resistance bridge meter reading ceases to rise. Then, the Solenoid Valve shall be immediately tested for MOPD operation at 85% ($\pm 0.25\%$) of rated coil voltage, or if preferred for DC Solenoid Valves, 85% of the equilibrium current. This is done by alternately de-energizing and energizing the solenoid valve coil to determine the MOPD at which the Solenoid Valve will operate consistently. The test shall be started with a value less than the anticipated MOPD and the solenoid valve inlet pressure increased until the MOPD is determined. This MOPD shall then be verified at the proper coil temperature as successive testing tends to vary the solenoid coil temperature.

C4.1.2.2 Record data in accordance with Section C5 after each reading.

C5 *Data to be Recorded.*

C5.1 *General Data.*

C5.1.1 Date

C5.1.2 Observers

C5.2 *Solenoid Valve Descriptive Data.*

C5.2.1 Manufacturer's name and address

C5.2.2 Model (if applicable)

C5.2.3 Designation (if applicable)

C5.2.4 Type (if applicable)

C5.2.5 Serial number (if applicable)

C5.2.6 Size (if applicable)

C5.2.7 Electrical characteristics

C5.2.7.1 Alternating current (AC)

C5.2.7.1.1 Voltage(s), V

C5.2.7.1.2 Frequency(s), Hz

C5.2.7.1.3 Power, W

C5.2.7.1.4 Current, A

C5.2.7.2 Direct current (DC)

C5.2.7.2.1 Voltage(s), V

C5.2.7.2.2 Power, W

C5.2.7.2.3 Current, A

C5.3 *MOPD Test Data.*

C5.3.1 Test fluid

C5.3.2 Ambient temperature, $^{\circ}\text{F}$

C5.3.3 Pressure of the fluid at the solenoid valve inlet, P_1 , psig

C5.3.4 Electrical characteristics used when heating the solenoid valve coil,

C5.3.4.1 AC voltage, V, and frequency, Hz

C5.3.4.2 DC voltage, V

C5.3.5 The DC resistance, ohms, of the solenoid valve coil at equilibrium temperature (maximum attained temperature) when it is energized by the electrical characteristics in Section C5.3.4.

C5.3.6 Electrical characteristics used when conducting the MOPD test: AC voltage, V, and frequency, Hz; DC voltage, V, or current, A

C5.3.7 MOPD value obtained, psi

APPENDIX D. RECOMMENDED STANDARD CONNECTION SIZES – INFORMATIVE

D1 Connection Sizes. Recommended standard connection sizes are listed in Table D1.

Table D1. Recommended Standard Connection Sizes¹			
Capacity, Tons		Nominal Connection Size, in (ODF ²)	
R-134a, R-407A, R-404A, , R-507A & R-600a	R-22, R-290, R-407C, R-410A	Inlet	Outlet
0.50	1.0	1/4	1/2
2.0	3.0	3/8	1/2
3.0	5.0	1/2	5/8
7.5	10	5/8	7/8
10	16	7/8	1-1/8
20	20	7/8	1-1/8
30	30	1-1/8	1-3/8
50	50	1-1/8	1-3/8
70	70	1-1/8	1-3/8
80	80	1-1/8	1-3/8
100	100	1-1/8	1-3/8

Note:

1. For capacities which fall between those listed, the larger connection size is the recommended standard.
2. ODF is Outside Diameter Flared.