

AHRI Standard 350

**2015 (R2021) Standard for
Sound Performance Rating
of Non-ducted Indoor Air-
conditioning and Heat
Pump Equipment**



we make life better*

2311 Wilson Boulevard, Suite 400
Arlington, VA 22201, USA
www.ahrinet.org
PH 703.524.8800
FX 703.562.1942

IMPORTANT

SAFETY DISCLAIMER

AHRI does not set safety standards and does not certify or guarantee the safety of any products, components or systems designed, tested, rated, installed or operated in accordance with this standard/guideline. It is strongly recommended that products be designed, constructed, assembled, installed and operated in accordance with nationally recognized safety standards and code requirements appropriate for products covered by this standard/guideline.

AHRI uses its best efforts to develop standards/guidelines employing state-of-the-art and accepted industry practices. AHRI does not certify or guarantee that any tests conducted under its standards/guidelines will be non-hazardous or free from risk.

Note:

This standard supersedes AHRI Standard 350-2008.

Foreword

- This standard references the sound intensity test method defined in ANSI/AHRI Standard 230, as an alternate method of test to the reverberation room test method defined in ANSI/AHRI Standard 220 for determination of sound power ratings.
- Provisions for addressing Concealed versus Exposed Equipment test configurations have been added.

TABLE OF CONTENTS

SECTION	PAGE
Section 1. Purpose.....	1
Section 2. Scope.....	1
Section 3. Definitions.....	1
Section 4. Test Requirements.....	2
Section 5. Rating Requirements.....	5
Section 6. Minimum Data Requirements for Published Ratings.....	6
Section 7. Marking and Nameplate Data	6
Section 8. Conformance Conditions.....	6

TABLES

Table 1. Reproducibility in the Determination of Non-ducted Equipment Sound Power Levels.....	5
---	---

FIGURES

Figure 1. Location of Equipment in the Test Room	3
--	---

APPENDICES

Appendix A. References – Normative	7
Appendix B. References – Informative	9
Appendix C. Examples of Various Types of Exposed and Concealed Equipment – Informative.....	10

FIGURES FOR APPENDICES

Figure C1. Exposed Sill Unit	10
Figure C2. Exposed Vertical Stack Unit	10
Figure C3. Exposed Horizontal Fan Coil Unit.....	11
Figure C4. Concealed Sill Unit	12
Figure C5. Concealed Vertical Stack Unit	12
Figure C6. Concealed Horizontal Fan Coil Unit.....	13
Figure C7. Concealed Vertical Stack Unit Test Setup – 5cm x 10cm Studs Cladded with 1.3cm Thick Drywall	14
Figure C8. Concealed Horizontal Stack Unit Test Setup – Cladded with 1.3cm Thick Drywall	14

SOUND PERFORMANCE RATING OF NON-DUCTED INDOOR AIR-CONDITIONING AND HEAT PUMP EQUIPMENT

Section 1. Purpose

1.1 Purpose. The purpose of this standard is to establish for Non-ducted Indoor Air-conditioning and Heat Pump Equipment definitions; test requirements; rating requirements; minimum data requirements for Published Ratings; marking and nameplate data; and conformance conditions.

1.1.1 Intent. This standard is intended for the guidance of the industry, including manufacturers, engineers, installers, contractors and users.

1.1.2 Review and Amendment. This standard is subject to review and amendment as technology advances.

Section 2. Scope

2.1 Scope. This standard applies to the indoor portions of factory-made Non-ducted Air-conditioning and Heat Pump Equipment as defined in ANSI/AHRI Standards 210/240, 340/360, 310/380, 440 and 1230. Products covered include but are not limited to: fan coils, air-source unitary heat pumps as well as unitary air-conditioners, water-source heat pumps, packaged terminal equipment, and variable refrigerant flow (VRF) systems.

Section 3. Definitions

All terms in this document will follow the standard industry definitions in the *ASHRAE Terminology* website (<https://www.ashrae.org/resources--publications/free-resources/ashrae-terminology>) unless otherwise defined in this section.

3.1 Concealed Equipment. Non-ducted Indoor Air-conditioning and Heat Pump Equipment that is designed to be located outside of the occupied space such that the casing radiated noise is acoustically isolated from the inlet and discharge sound. Refer to Appendix C for examples of various types of Concealed Equipment configurations.

3.2 Exposed Equipment. Non-ducted Indoor Air-conditioning and Heat Pump Equipment that is in the occupied space such that the casing radiated noise is included with the inlet and discharge sound. Refer to Appendix C for examples of various types of Exposed Equipment configurations.

3.3 Hertz (Hz). A unit of frequency equal to one cycle per second.

3.4 Non-ducted Indoor Air-conditioning and Heat Pump Equipment. For the purposes of this standard, non-ducted equipment communicates with the occupied space by free delivery and inlet or through enclosed airways with lengths less than 1 effective duct diameter.

3.5 Octave Band. A band of sound covering a range of frequencies such that the highest is twice the lowest. The Octave Bands used in this standard are those defined in ANSI/ASA Standard S1.11.

3.6 One-third Octave Band. A band of sound covering a range of frequencies such that the highest frequency is the cube root of two times the lowest frequency. The One-third Octave Bands used in this standard are those defined in ANSI/ASA Standard S1.11.

3.7 Published Rating. A statement of the assigned values of those performance characteristics, under stated rating conditions, by which a unit may be chosen to fit its application. These values apply to all units of like nominal size and type (identification) produced by the same manufacturer. As used herein, the term Published Rating includes the rating of all performance characteristics shown on the unit or published in specifications, advertising or other literature controlled by the manufacturer, at stated rating conditions.

3.7.1 Application Rating. A rating based on tests performed at application Rating Conditions (other than Standard Rating Conditions).

3.7.2 Standard Rating. A rating based on tests performed at Standard Rating Conditions.

3.8 Reference Sound Source (RSS). Portable, aerodynamic sound source that produces a known stable broad band sound power output as defined in ANSI/AHRI Standard 250.

3.9 Reproducibility. Deviations in test results are obtained with the same method on identical test items in different laboratories with different operators using different equipment.

3.10 “Shall” or “Should”. “Shall” or “should” shall be interpreted as follows:

3.10.1 Shall. Where “shall” or “shall not” is used for a provision specified, that provision is mandatory if compliance with the standard is claimed.

3.10.2 Should. “Should” is used to indicate provisions which are not mandatory but which are desirable as good practice.

3.11 Sound Power Level, L_w . Ten times the logarithm to the base ten of the ratio of the sound power radiated by the source to a reference sound power, expressed in decibels, dB. The reference sound power used in this standard is 1 picowatt, pW.

3.11.1 A-weighted Sound Power Level, L_{wA} . The logarithmic summation of A-weighted, one-third octave band Sound Power Levels.

3.12 Sound Pressure Level, L_p . Twenty times the logarithm to the base ten of the ratio of a given sound pressure to a reference sound pressure of 20 μ Pa, expressed in decibels, dB.

3.13 Sound Quality Indicator (SQI). The calculated metric determined when following the procedure contained in ANSI/AHRI Standard 1140 for quantifying sound quality whereby measured sound levels are weighted to adjust for psychoacoustic sensitivity to frequency distribution and any discrete tones which may be present and then converted to a single number Sound Quality Indicator.

Section 4. Test Requirements

4.1 Test Requirements. Unit Sound Power Level shall be determined by tests conducted in a reverberation room or using sound intensity.

4.1.1 If the reverberation room method is used, Sound Power Levels for the unit under test shall be determined according to ANSI/AHRI Standard 220. The reverberation room shall meet the requirements of and be qualified in accordance with ANSI/AHRI Standard 220, except as noted within the body of this standard. A RSS shall be used that meets the performance requirements and is calibrated per ANSI/AHRI Standard 250

4.1.2 If the sound intensity method is used, Sound Power Levels for the unit under test shall be conducted in accordance with ANSI/AHRI Standard 230.

4.1.3 Measured sound data shall be in One-third Octave Bands (100 Hz to 10,000 Hz are required, 50 Hz to 80 Hz are optional) in accordance with the procedures specified above for the method of test being used. A record shall be made of the actual equipment thermal rating conditions under which the equipment was tested. In addition, the equipment volumetric flow rate, m³/s, and external static pressure, kPa gage, shall be recorded.

4.2 Setup of Equipment for Testing. Equipment shall be mounted in a way that is representative of a design application of the product.

4.2.1 Position A (Figure 1) – Mounted away from wall.

4.2.2 Position B (Figure 1) – Mounted against or through the wall with the bottom of equipment on the floor. The equipment shall be mounted at the minimum manufacturer’s recommended projection into the room.

4.2.3 Position C (Figure 1) – Mounted against or through the wall but the bottom of equipment is not on the floor. The equipment shall be mounted at the minimum manufacturer’s recommended projection into the room.

4.2.4 Position D (Figure 1) – Ceiling mounted equipment may be suspended from the sound room ceiling or from a frame device or mounted on rails rigidly supported, for example, by concrete blocks.

4.2.5 All equipment shall be mounted according to the manufacturer’s installation instructions. If any deviations from these instructions are necessary, they shall be done in a manner that will not affect the acoustic performance of the equipment.

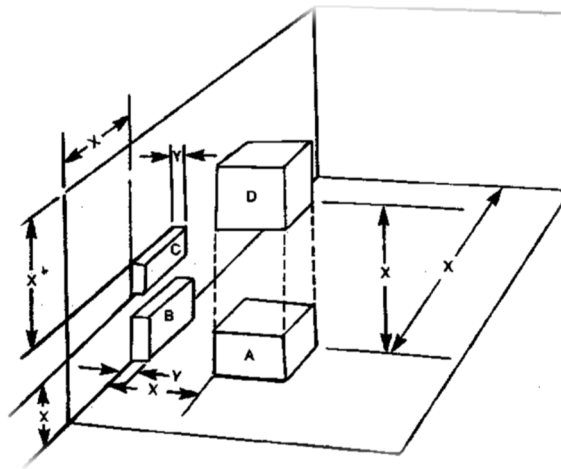

- A = Location for equipment used away from a wall
- B = Location for equipment used against or through the wall on the floor
- C = Location for equipment mounted against or through a wall
- D = Location for equipment suspended or fastened to ceiling
- X = 1.5 m minimum to adjoining room surfaces(s) other than mounting plane
- Y = Manufacturers recommended minimum

Figure 1. Location of Equipment in the Test Room

4.2.6 In the case of wall-mounted equipment, the mounting wall shall be a heavy masonry or equivalent construction, or auxiliary mounting platform shall be provided, to minimize wall vibration effects.

4.2.7 Exposed, non-ducted equipment shall be setup in the test room without enclosure or ductwork.

4.2.8 Concealed Equipment shall be installed with the casing radiated noise acoustically isolated from the measured combined inlet and discharge sound and operated at free-delivery conditions. Acoustic isolation shall be achieved with either:

4.2.8.1 A stud construction enclosure with a minimum of 12 mm drywall or equivalent. The enclosure shall not be in contact with the equipment under test except at the inlet and outlet. Installation shall be mid-wall style (conforming to Figure 1, and as suggested in Figure C7), unless otherwise specified in the manufacturer’s installation, operation and maintenance (IOM) manual.

4.2.8.2 Direct attachment of 12 mm drywall to the equipment with sheet metal screws or adhesive.

The laboratory shall record details of the construction enclosure, including: stud type, orientation and spacing, drywall thickness, spacing between the equipment and drywall and sound absorptive material if present. If direct attached the attachment method shall be noted.

A description of any grills, diffusers or acoustic panels used in the test setup shall be recorded.

4.2.9 Concealed Equipment with either the inlet or discharge airway ducted shall be rated in accordance with ANSI/AHRI Standards 260 (I-P) and 261 (SI). For the purposes of this standard, a duct is an enclosed airway with a length greater than 1 effective diameter according to Equation 1.

$$D = \left(\frac{4 \cdot A}{\pi} \right)^{1/2}$$

1

Where:

A = Cross-sectional area of the duct, m²

D = Effective diameter, m

4.3 *Electrical Characteristics.* Tests shall be performed at the rated voltage(s), phase, and frequency specified on the unit nameplate and measured at the unit service connection.

4.4 *Air Quantity.* The volumetric flow rate of both indoor and outdoor fans (if any) shall be the same as required to produce the rated capacity under the appropriate AHRI standard.

4.5 *Operation.* All components required to produce the standard rating cooling capacity under the appropriate AHRI standard shall be operated while data is being taken. Standard Rating Conditions (cooling) for the appropriate standard shall be maintained.

4.5.1 For free-delivery air-source heat pumps rated under ANSI/AHRI Standards 210/240, 340/360, and 310/380, the heating mode shall also be used to sound rate this equipment using the following conditions:

Indoor dry bulb:	21.0°C
Outdoor dry bulb:	18.0°C
Outdoor wet bulb:	13.0°C

4.5.2 Room fan-coil air-conditioners rated per ANSI/AHRI Standard 440 shall be tested without water circulating through the coil.

4.5.3 Indoor Variable Refrigerant Flow (VRF) units rated per ANSI/AHRI Standard 1230 shall be tested with refrigerant circulating through the evaporator.

4.6 *Test Condition Tolerances.* The allowable tolerances for sound ratings are as follows:

Air temperature:	±1.0 °C
Water temperature:	±1.0 °C

When the indoor-side loading is simulated by a method not requiring air, the following tolerances apply:

Suction gas temperature at compressor:	±3.0°C
Evaporator pressure:	±14 kPa

Note: Suction gas temperature at the compressor is applicable only when the suction gas superheat temperature is at least 6.0 K in the equivalent Standard Rating test specified in the AHRI standard for the equipment being tested.

4.7 *Test Method Measurement Reproducibility.* Sound Power Levels obtained from either reverberant room or sound intensity methods made in conformance with this standard will result in measurement standard deviations which are equal to or less than those in Table 1. For the reverberation room method this table represents the uncertainty that would result from using ANSI/AHRI Standard 220 and a Reference Sound Source calibrated per ANSI/AHRI Standard 250. For the sound intensity method the uncertainties in this table include uncertainty in the sound intensity measurement due to the test environment, background noise levels and selection of measurement points as defined in ANSI/AHRI Standard 230. The standard deviations in Table 1 do not account for variations of sound power caused by changes in operating conditions.

Table 1. Reproducibility in the Determination of Non-ducted Equipment Sound Power Levels		
Octave Band Center Frequency, Hz	One-third Octave Band Center Frequency, Hz	Maximum Standard Deviation of Reproducibility, dB
63	50 to 80	4.0
125	100 to 160	3.0
250	200 to 315	2.0
500 to 4,000	400 to 5,000	1.5
8,000	6,300 to 10,000	3.0

Section 5. Rating Requirements

5.1 *Introduction.* The sound ratings shall be comprised of:

- 5.1.1** Un-weighted Octave Band Sound Power Levels, L_w , dB (125 Hz to 8,000 Hz are required, 63 Hz is optional)
- 5.1.2** Overall A-weighted Sound Power Level, L_{wA} , dB (value based on 100 Hz to 10,000 Hz is required, based on 50 Hz to 10,000 Hz is optional).
- 5.1.3** Sound Quality Indicator (SQI) per ANSI/AHRI Standard 1140 (optional)
- 5.1.4** Un-weighted one-third Octave Band Sound Power Levels, dB (optional)

5.2 *Determination of Sound Power Levels.* The unit under test shall be set up and tested per Section 4 of this standard.

- 5.2.1** One-third Octave Band Sound Power Level Calculations. For the reverberation room method these unit levels shall be determined per ANSI/AHRI Standard 220 Section 6.5. For the sound intensity method the unit levels shall be determined per ANSI/AHRI Standard 230 Section 7.2 for discrete points and Section 7.3 for scanning.
- 5.2.2** Octave Band Sound Power Level Calculations. For the reverberation room method the octave band sound power level shall be determined per ANSI/AHRI Standard 220 Section 6.6. For the sound intensity method the octave band sound power level shall be determined per AHRI Standard 230 Section 7.4.
- 5.2.3** A-weighted Sound Power Level Calculations. For the reverberation room method the A-weighted Sound Power Level shall be determined per ANSI/AHRI Standard 220 Section 6.7. For the sound intensity method the A-weighted Sound Power Level shall be determined per ANSI/AHRI Standard 230 Section 7.5.

The A-weighted Sound Power Level and octave band sound power levels shall be rounded to the nearest decibel.

5.3 *Sound Quality Indicator Calculation (Optional).* If the Sound Quality Indicator of the outdoor unit is to be determined the procedures in ANSI/AHRI Standard 1140 shall be used. The SQI can be used for both full unit operation and fan(s) only operation.

5.4 *Rating Tolerances.* Any indoor unitary equipment tested in accordance with this standard shall not be higher than the Published Ratings in Octave Band Sound Power Levels, L_w , and Overall A-weighted Sound Power Level, L_{wA} . An optional Sound Quality Indicator (SQI) or optional one-third octave band Sound Power Levels can be determined, none of which shall be higher than its Published Rating.

Section 6. Minimum Data Requirements for Published Ratings

6.1 *Published Ratings.* Published sound power ratings shall be for the unit with all components running that are necessary to produce the AHRI standard thermal rating. The sound power ratings shall include values as described in Sections 6.1.1 and 6.1.2 as listed below. The sound power rating values as described in Sections 6.1.3 and 6.1.4 are optional. Additionally, sound power data may be published for the unit operating with only the fan(s) running.

6.1.1 The un-weighted Octave Band Sound Power Levels to the nearest decibel from 125 Hz to 8,000 Hz (63 Hz is optional).

6.1.2 The overall A-weighted Sound Power Level to the nearest decibel covering the range of 100 Hz to 10,000 Hz (or optionally from 50 Hz to 10,000 Hz).

6.1.3 Optionally, the Sound Quality Indicator (SQI) may be published. The SQI shall be rounded to the nearest 0.1.

6.1.4 Optionally, the un-weighted One-third Octave Band Sound Power Levels to the nearest 0.1 dB may be published.

6.2 *Standard Sound Rating.* When AHRI standard thermal rating conditions have been established for the equipment, a standard sound rating shall be published for the unit operating at those conditions.

6.3 *Reporting Requirements.* All claims to sound ratings in product literature within the scope of this standard shall include the statement “Rated in accordance with ANSI/AHRI Standard 350”. Manufacturer’s published literature shall include:

6.3.1 Method of sound test (ANSI/AHRI Standard 220 or ANSI/AHRI Standard 230)

6.3.2 Thermal rating conditions (standard and application rating points)

6.3.3 Whether the equipment was tested in an exposed equipment or concealed equipment setup. If tested in a concealed equipment setup, the information required in Section 4.2.8 shall be reported.

Section 7. Marking and Nameplate Data

7.1 *Marking and Nameplate Data.* As a minimum, the nameplate shall display the manufacturer's name, model designation, and electrical characteristics.

Nameplate voltages for 60 Hz systems shall include one or more of the equipment nameplate voltage ratings shown in Table 1 of ANSI/AHRI Standard 110. Nameplate voltages for 50 Hz systems shall include one or more of the utilization voltages shown in Table 1 of IEC Standard 60038.

Section 8. Conformance Conditions

8.1 *Conformance.* While conformance with this standard is voluntary, conformance shall not be claimed or implied for products or equipment within the standard’s *Purpose* (Section 1) and *Scope* (Section 2) unless such claims meet all of the requirements of the standard and all of the testing and rating requirements are measured and reported in complete compliance with the standard. Any product that has not met all the requirements of the standard shall not reference, state, or acknowledge the standard in any written, oral, or electronic communication.

APPENDIX A. REFERENCES – NORMATIVE

A1 Listed here are all standards, handbooks and other publications essential to the formation and implementation of the standard. All references in this appendix are considered as part of this standard.

A1.1 ANSI/AHRI Standard 110-2012, *Air-Conditioning and Refrigerating Equipment Nameplate Voltages*, 2012, Air-Conditioning, Heating, and Refrigeration Institute, 2311 Wilson Blvd, Suite 400, Arlington, VA 22201, U.S.A.

A1.2 ANSI/AHRI Standard 210/240-2008 with Addenda 1 and 2, *Performance Rating of Unitary Air-Conditioning and Air Source Heat Pump Equipment*, 2008, Air-Conditioning, Heating, and Refrigeration Institute, 2311 Wilson Blvd, Suite 400, Arlington, VA 22201, U.S.A.

A1.3 ANSI/AHRI Standard 220-2012, *Reverberation Room Qualification and Testing Procedures for Determining Sound Power of HVAC Equipment*, 2012, Air-Conditioning, Heating, and Refrigeration Institute, 2311 Wilson Blvd, Suite 400, Arlington, VA 22201, U.S.A.

A1.4 ANSI/AHRI Standard 230-2013, *Sound Intensity Testing Procedures for Determining Sound Power of HVAC Equipment*, 2013, Air-Conditioning, Heating, and Refrigeration Institute, 2311 Wilson Blvd, Suite 400, Arlington, VA 22201, U.S.A.

A1.5 ANSI/AHRI Standard 250-2008 with Addendum 1, *Performance and Calibration of Reference Sound Sources Equipment*, Air-Conditioning, Heating, and Refrigeration Institute, 2008, 2311 Wilson Blvd, Suite 400, Arlington, VA 22201, U.S.A.

A1.6 ANSI/AHRI Standard 260 (I-P)-2012, *Sound Rating of Ducted Air Moving and Conditioning Equipment*, 2012, Air-Conditioning, Heating, and Refrigeration Institute, 2311 Wilson Blvd, Suite 400, Arlington, VA 22201, U.S.A.

A1.7 ANSI/AHRI Standard 261 (SI)-2012, *Sound Rating of Ducted Air Moving and Conditioning Equipment*, 2012, Air-Conditioning, Heating, and Refrigeration Institute, 2311 Wilson Blvd, Suite 400, Arlington, VA 22201, U.S.A.

A1.8 ANSI/AHRI Standard 340/360-2015, *Performance Rating of Commercial and Industrial Unitary Air-conditioning and Heat Pump Equipment*, 2015, Air-Conditioning, Heating, and Refrigeration Institute, 2311 Wilson Blvd, Suite 400, Arlington, VA 22201, U.S.A.

A1.9 ANSI/AHRI Standard 440-2008 with Addendum 1, *Performance Rating of Room Fan-Coils*, 2008, Air-Conditioning, Heating, and Refrigeration Institute, 2311 Wilson Blvd, Suite 400, Arlington, VA 22201, U.S.A.

A1.10 ANSI/AHRI/CSA Standard 310/380-2014 (CSA-C744-14), *Packaged Terminal Air-Conditioners and Heat Pumps*, Air-Conditioning, Heating, and Refrigeration Institute, 2014, 2311 Wilson Blvd, Suite 400, Arlington, VA 22201, U.S.A.

A1.11 ANSI/AHRI Standard 1140-2012, *Sound Quality Evaluation Procedures for Air-Conditioning and Refrigeration Equipment*, 2012, Air-Conditioning, Heating, and Refrigeration Institute, 2111 Wilson Boulevard, Suite 500, Arlington, VA 22201, U.S.A.

A1.12 ANSI/AHRI Standard 1230-2010 with Addendum 2, *Performance Rating of Variable Refrigerant Flow (VRF) Multi-Split Air-Conditioning and Heat Pump Equipment*, 2010, Air-Conditioning, Heating, and Refrigeration Institute, 2311 Wilson Blvd, Suite 400, Arlington, VA 22201, U.S.A.

A1.13 ANSI/ASA Standard S1.11-2004, *Specification for Octave-Band and Fractional Octave-Band Analog and Digital Filters*, 2004, American National Standards Institute, 25 West 43rd Street, 4th Fl., New York, NY 10036, U.S.A.

A1.14 ASHRAE Terminology, <https://www.ashrae.org/resources--publications/free-resources/ashrae-terminology>, 2014, ASHRAE, Inc., 180 Technology Parkway, Peachtree Corners, GA 30092, U.S.A.

A1.15 IEC Standard 60038, *IEC Standard Voltages*, 2002, International Electrotechnical Commission, 3, rue de Varembe, P.O. Box 131, 1211 Geneva 20, Switzerland.

APPENDIX B. REFERENCES – INFORMATIVE

B1 Listed are standards, handbooks, and other publications which may provide useful information and background but are not considered essential. References in this appendix are not considered part of the standard.

None.

APPENDIX C. EXAMPLES OF VARIOUS TYPES OF EXPOSED AND CONCEALED EQUIPMENT – INFORMATIVE

C1 Figures C1, C2, and C3 show examples of typical free inlet and discharge fan coils exposed in the conditioned space.

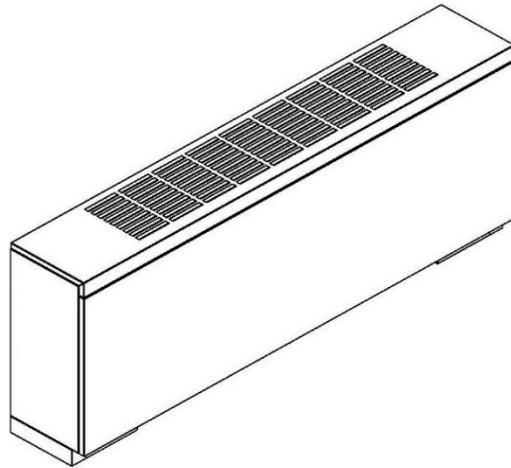

Figure C1. Exposed Sill Unit

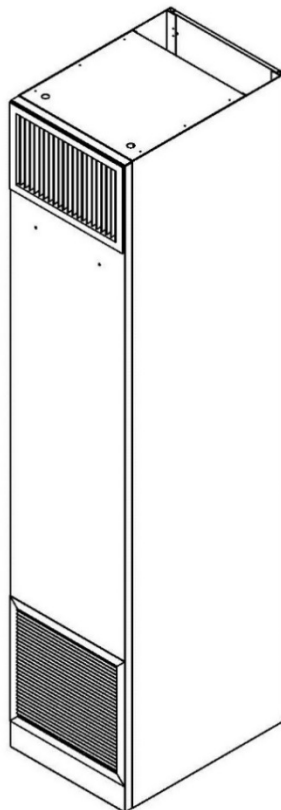

Figure C2. Exposed Vertical Stack Unit

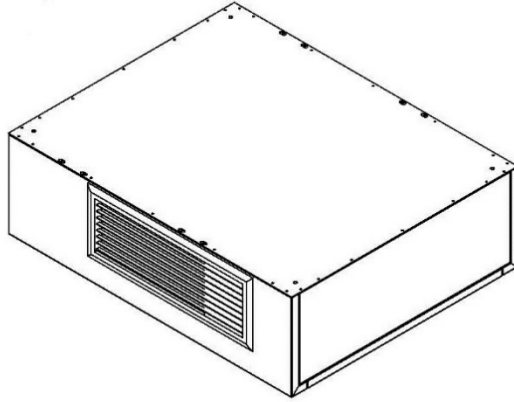

Figure C3. Exposed Horizontal Fan Coil Unit

C2 Figures C4, C5, and C6 show examples of typical free inlet and discharge fan coils concealed near the conditioned space.

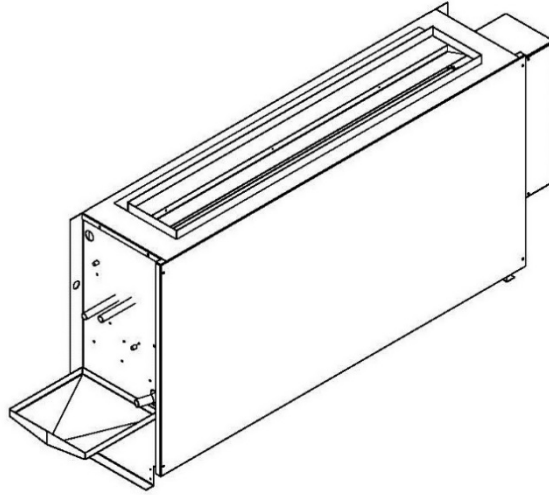

Figure C4. Concealed Sill Unit

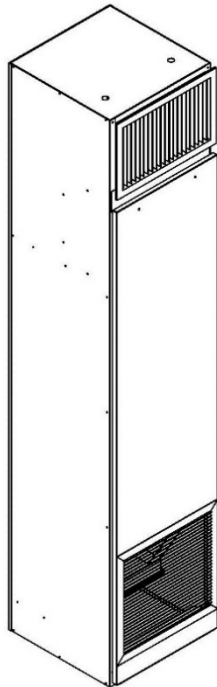

Figure C5. Concealed Vertical Stack Unit

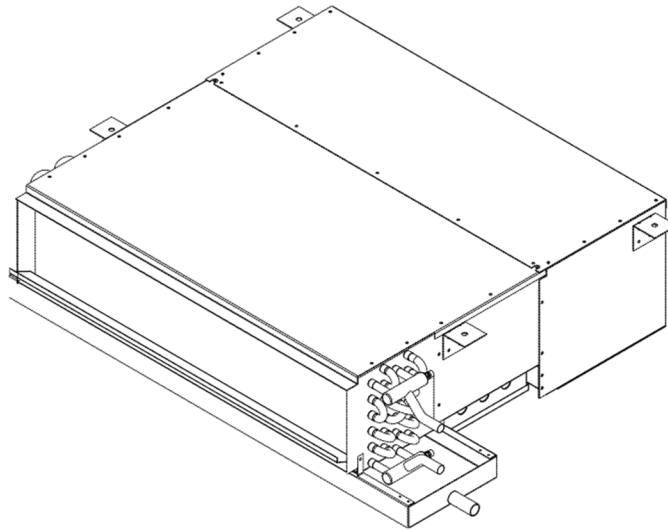

Figure C6. Concealed Horizontal Fan Coil Unit

C3 Figures C7 and C8 show examples of typical concealed horizontal and vertical stack units.

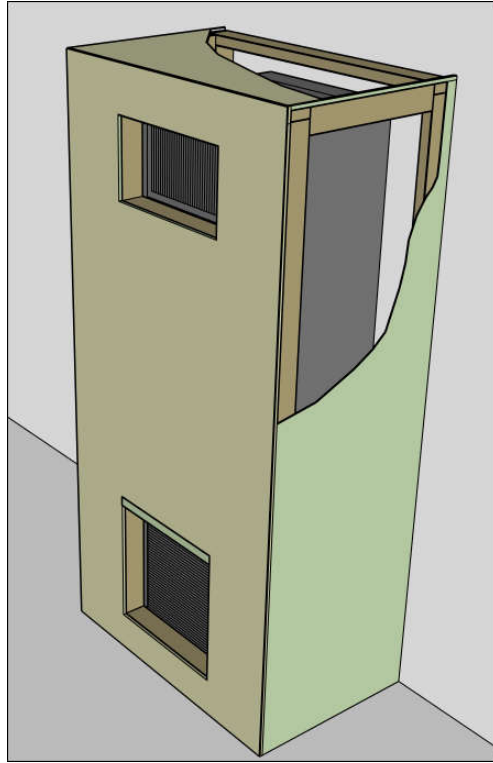

Figure C7. Concealed Vertical Stack Unit Test Setup – 5cm x 10cm Studs Cladded with 1.3cm Thick Drywall

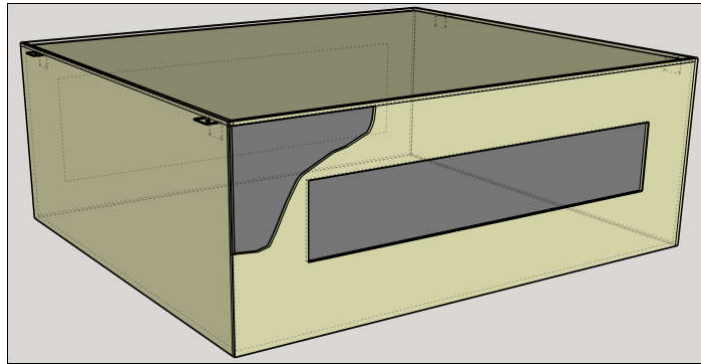

Figure C8. Concealed Horizontal Fan Coil Unit Test Setup – Cladded with 1.3cm Thick Drywall