

ANSI/AHRI Standard 431 (SI)

2020 Standard for

**Performance Rating of Central
Station Air-handling Unit Supply
Fans**



we make life better*

2311 Wilson Boulevard, Suite 400
Arlington, VA 22201, USA
www.ahrinet.org
PH 703.524.8800
FX 703.562.1942

Approved by ANSI on 8 June 2023



©Copyright 2020, by Air-Conditioning, Heating, and Refrigeration Institute
Registered United States Patent and Trademark Office
Printed in U.S.A.

IMPORTANT

SAFETY DISCLAIMER

AHRI does not set safety standards and does not certify or guarantee the safety of any products, components or systems designed, tested, rated, installed or operated in accordance with this standard/guideline. It is strongly recommended that products be designed, constructed, assembled, installed and operated in accordance with nationally recognized safety standards and code requirements appropriate for products covered by this standard/guideline.

AHRI uses its best efforts to develop standards/guidelines employing state-of-the-art and accepted industry practices. AHRI does not certify or guarantee that any tests conducted under its standards/guidelines will be non-hazardous or free from risk.

ICS Code: 27.200

Note:

This standard supersedes AHRI Standard 431-2014 with Addendum 1.
For I-P ratings, see ANSI/AHRI Standard 430-2020.

This standard was approved as an American National Standard (ANS) on 8 June 2023.

AHRI CERTIFICATION PROGRAM DISCLAIMER

AHRI Standards are developed independently of AHRI Certification activities and can have scopes that include products that are not part of the AHRI Certification Program. The scope of the applicable AHRI Certification Program can be found on AHRI's website at <http://www.ahrinet.org>.

TABLE OF CONTENTS

SECTION	PAGE
Section 1. Purpose.....	1
Section 2. Scope.....	1
Section 3. Definitions.....	1
Section 4. Classifications.....	4
Section 5. Test Requirements.....	5
Section 6. Rating Requirements.....	16
Section 7. Symbols and Subscripts.....	16
Section 8. Minimum Data Requirements for Published Ratings.....	18
Section 9. Marking and Nameplate Data.....	18
Section 10. Conformance Conditions.....	18

TABLES

Table 1. Number of Motors to be Calibrated.....	9
Table 2. Minimum Number of Power Connections to be Measured.....	10

FIGURES

Figure 1. Ducted Fan Discharge - Horizontal Arrangement.....	3
Figure 2. Unducted Fan Discharge - Horizontal Arrangement.....	4
Figure 3. Outlet Test Unit Configuration for Multiple Parallel Housed Fans in CSAHUs with Individual Ducted Discharges.....	6
Figure 4. Single Outlet Test Unit Configuration for Single or Multiple Parallel Plenum Fans in CSAHUs with Full Face Opening Axial Discharge.....	7
Figure 5. Inlet Chamber Setup – Multiple Nozzles in Chamber.....	8
Figure 6. Outlet Chamber Setup – Multiple Nozzles in Chamber.....	8

Figure 7. Ducted Fan Discharge CSAHU with Airflow Direction Change.....	12
Figure 8. Fan and Unit Characteristics - Fan Rated and Unit Tested	14
Figure 9. Fan and Unit Characteristics - Fan Rated and Unit Calculated.....	15

APPENDICES

Appendix A. References – Normative	19
Appendix B. References – Informative	20
Appendix C. Criteria for Proportionality-Informative.....	21
Appendix D. Example Fan Array Calculation-Informative.....	26
Appendix E. Correcting for Pressure Drop Through the Test Equipment for Unducted Discharge Tests - Normative	29
Appendix F. Units with Inlet Guide Vanes – Informative.....	35
Appendix G. Wire-to-Air Measurement - Calculation to Other Speeds and Densities – Normative	36
Appendix H. Fan Electrical Power with a Separately Tested Motor or Combined Motor Controller – Normative	38

FIGURES FOR APPENDICES

Figure C1. Dimensions Used for Proportionality Equations - Housed Fan.....	23
Figure C2. Dimensions Used for Proportionality Equations - Plenum Fan.....	23
Figure C3. Dimensions Used for Proportionality Equations - Axial Fan	24
Figure C4. Dimensions Used for Proportionality Equations – Multiple Fans (End Views).....	24
Figure C5. Example Contained Fan Array	25
Figure C6. Example Uncontained Fan Array	25
Figure D1. Example Scatterplot with Motor Calibration Data According to Table 1	26
Figure D2. Example Scatterplot with Motor Calibration Data Not According to Table 1	28
Figure E1. Unit Tested with Discharge Plenum Supplied by the Manufacturer	31

Figure E2. Unit Tested with Discharge Plenum Constructed by the Laboratory	32
Figure E3. Unit Tested with Inlet Plenum Provided by the Manufacturer	33
Figure E4. Unit Tested with Inlet Plenum Constructed by The Laboratory	34
Figure F1. Dimensions for Inlet Vane Proportionality	35
Figure H1. Fan Power and Drive Components	38
Figure H2. Example of Interpolation (Efficiency vs. Torque and Speed)	41
Figure H3. Example of Curve Fit (Efficiency vs. Power and Speed)	41

TABLES FOR APPENDICES

Table D1. Example Motor Calibration Data Following Table 1	26
Table D2. Example Motor Calibration Data Not Following Table 1	27
Table H1. Scope of Appendix H and its Application	39
Table H2. Example of Determination Points	40
Table H3. Example of PDS Test Results	40

PERFORMANCE RATING OF CENTRAL STATION AIR-HANDLING UNIT SUPPLY FANS

Section 1. Purpose

1.1 *Purpose.* The purpose of this standard is to establish for Central Station Air-handling Unit Supply Fans: definitions; classifications; test requirements; rating requirements; minimum data requirements for Published Ratings; marking and nameplate data; and conformance conditions.

1.1.1 *Intent.* This standard is intended for the guidance of the industry, including manufacturers, engineers, installers, contractors, and users.

1.1.2 *Review and Amendment.* This standard is subject to review and amendment as technology advances.

Section 2. Scope

2.1 *Scope.* This standard applies to Central Station Air-handling Units, as defined in Section 3.

2.1.1 This standard applies to Supply Fan ratings for Central Station Air-handling Units with Plenum Fans in a cabinet, Fan Arrays, Housed Centrifugal Fans, and Axial Fans.

(Informative Note: Fan and motor assemblies that are not intended to be separated are within the scope of this standard with the addition of the electrical power measurement method in Section 5.1.1.)

2.2 *Exclusions.*

2.2.1 This standard does not apply to unit heaters intended for free delivery of heated air or to room fan-coils as defined in AHRI Standard 440.

2.2.2 This standard does not apply to units that have direct expansion coils incorporated by the manufacturer in a matched split system air-conditioner, or as otherwise defined in AHRI Standard 210/240 or in AHRI Standard 340/360.

2.2.3 This standard does not apply to unit ventilators as defined in AHRI Standard 840.

2.2.4 This standard does not apply to DX Dedicated Outdoor Air System Units as defined in AHRI Standard 920.

2.2.5 This standard does not apply to Computer and Data Processing Room Air Conditioners as defined in AHRI Standard 1360.

Section 3. Definitions

All terms in this document will follow the standard industry definitions in the *ASHRAE Terminology* website (<https://www.ashrae.org/resources--publications/free-resources/ashrae-terminology>) unless otherwise defined in this Section.

3.1 *Actual Cubic Meters Per Second (Actual m^3/s), m^3/s .* The unit of airflow uncorrected for air density. All airflow in this standard is considered to be actual airflow rate.

3.2 *Appurtenances.* Equipment added to a CSAHU for purposes including but not limited to control, isolation, safety, static pressure regain, wear, etc. Appurtenances include, but are not limited to coils, filters, energy recovery devices, dampers, air-mixers, spray assemblies, eliminators, discharge plenums, and inlet plenums

3.3 *Central Station Air-handling Unit (CSAHU).* A factory-made encased assembly consisting of a Supply Fan or Fans in parallel which may also include other necessary equipment to perform one or more of the functions of circulating, cleaning, heating, cooling, humidifying, dehumidifying and mixing of air. It shall not contain a source of mechanical cooling. The CSAHU shall have a maximum design external static pressure (ESP) greater than 250 Pa.

Note: While the ESP for a specific application may be less than 250 Pa, any units generally capable of delivering greater than 250 Pa ESP shall be considered to be a CSAHU.

3.3.1 *Ducted Fan Discharge CSAHU.* A unit that has a ducted fan outlet. (See Figure 1. Note that Figure 1 applies to Housed Centrifugal Fan and Axial Fans and that a Housed Centrifugal Fan is shown.)

3.3.2 *Unducted Fan Discharge CSAHU.* A unit containing a fan that does not have a ducted fan outlet. (See Figure 2. Note that Figure 2 applies to all fan types in the standard and that a Housed Centrifugal Fan is shown.)

3.4 *Fan Electrical Power (FEP), kW.* Electrical input power required to operate the Fan System at the Rating Point.

3.5 *Fan System.* Includes the Supply Fan, motor, and may include belt transmission, and/or a Motor Controller.

3.6 *Full Face Opening Axial Discharge.* Where the discharge opening of the CSAHU is the same cross-sectional dimensions as the interior of the CSAHU's casing and the direction of the airflow is parallel with the shaft of the fan or fans.

3.7 *Motor Controller.* A power electronic device that regulates the speed of a motor.

3.8 *Power Connection.* One or more points on the exterior and/or interior of the CSAHU intended for providing electricity from the supply mains to the unit. The points may supply multiple motors or Motor Controllers.

3.9 *Power Drive System (PDS):* An adjustable-speed electric AC power drive system, which includes a motor and the semiconductor power converter with means for control, protection, monitoring, and measurement of motors.

3.10 *Published Rating.* A statement of the assigned values of those performance characteristics, under stated Rating Conditions, by which a unit may be chosen to fit its application. These values apply to all units of like nominal capacity and type (identification) produced by the same manufacturer. As used herein, the term Published Rating includes the rating of all performance characteristics shown on the unit or published in specifications, advertising or other literature controlled by the manufacturer, at stated Rating Conditions.

3.11 *Rating Conditions.* Any set of operating conditions under which a single level of performance results and causes only that level of performance to occur.

3.12 *Rating Point.* A single airflow, air density, and pressure point within the published operating range of the fan.

3.13 *"Shall" or "Should".* "Shall" or "should" shall be interpreted as follows:

3.13.1 *Shall.* Where "shall" or "shall not" is used for a provision specified, that provision is mandatory if compliance with the standard is claimed.

3.13.2 *Should.* "Should" is used to indicate provisions which are not mandatory but which are desirable as good practice.

3.14 *Standard Air.* Air weighing 1.2 kg/m³ which approximates dry air at 21°C and at a barometric pressure of 101.3 kPa.

3.15 *Supply Fan.* The fan that provides enough pressure to overcome the supply air restriction and may provide some or all of the pressure to overcome the return air restriction to provide air into the conditioned space.

3.15.1 Axial Fan. A housed fan that moves air in the general direction of the axis about which it rotates. This includes tubeaxial fans, centaxial fans, and vaneaxial fans. Fan rotor or wheel within a tubular-type casing that includes supports for either Belt Drive or Direct Drive.

3.15.2 Belt Drive. Driver and driven fans with positive belted connections for rotations at any speed.

3.15.3 Direct Drive. Driver and driven fans with positive direct connections for rotations at the same speed.

3.15.4 Fan Array. A matrix of regularly spaced direct-drive Supply Fans operating in parallel with inflow from a common inlet plenum and with outflow into a common outlet plenum. All impellers and motors must be of Identical Construction. All Operating Fans must run at the same speed. If applicable, all Variable Frequency Drives must be programmed to provide identical frequency and voltage.

3.15.4.1 Contained Fan. Fans in a Fan Array that are within substantially uniform enclosure(s) and do not aerodynamically interact with each other within the array.

3.15.4.2 Partially Contained Fan. Fans in a Fan Array that are within non-uniform enclosure(s) and some Supply Fans aerodynamically interact with each other within the array.

3.15.4.3 Uncontained Fan. Fans in an array that aerodynamically interact with each other.

3.15.5 Fan Housing. The stationary element which guides the air before and after the fan’s impeller.

3.15.6 Housed Centrifugal Fan. Fan in which the air enters the impeller axially and leaves it substantially in a radial direction. Fan rotor or wheel within a scroll-type casing (shroud) that includes supports for either Belt Drive or Direct Drive.

3.15.7 Identical Construction. A product which has the same manufacturer, the same model number, and is intended to have the same performance under the same conditions. Exception: the model numbers may differ if the only difference between the models is something which does not affect performance (e.g. color).

3.15.8 Operating Fan. Any Supply Fan which is designated by the CSAHU manufacturer to be energized and rotating at the specified Rating Condition

3.15.9 Plenum Fan. A fan assembly consisting of a single inlet impeller mounted perpendicular to airflow that pressurizes a plenum chamber in an air-distribution system.

3.16 Variable Frequency Drive (VFD). A power electronic device that regulates the speed of an alternating current (AC) motor by adjusting the frequency and the voltage of the electrical power supplied to the motor.

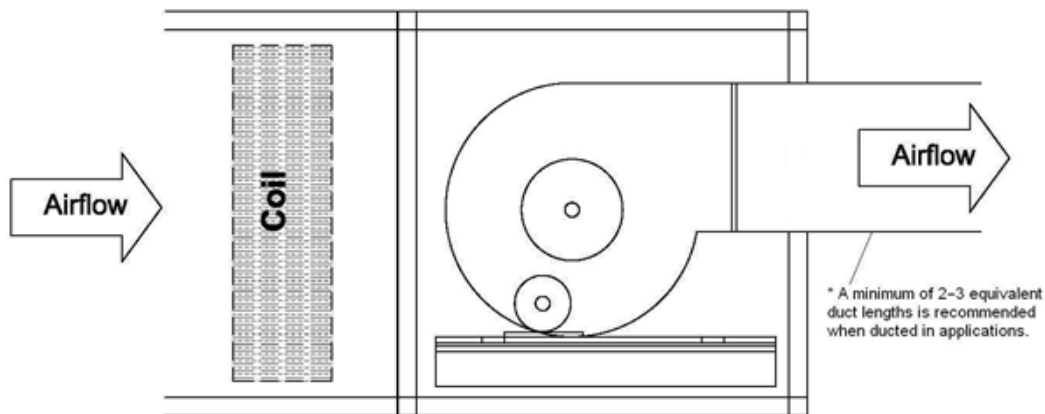

Figure 1. Ducted Fan Discharge – Horizontal Arrangement

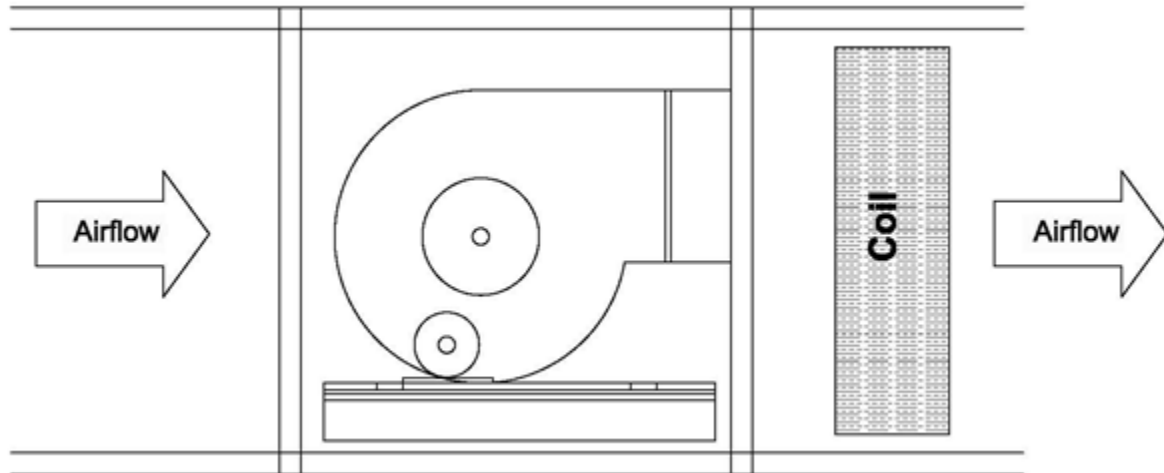

Figure 2. Unducted Fan Discharge – Horizontal Arrangement

Section 4. Classifications

4.1 *Methods of Classification.* Equipment covered within the scope of this standard shall be classified as shown:

4.1.1 *Unit Type.*

4.1.1.1 Ducted Discharge

4.1.1.2 Unducted Discharge

4.1.2 *Fan Type.*

4.1.2.1 Housed Centrifugal

4.1.2.1.1 Airfoil/Backward Inclined/Backward Curved

4.1.2.1.2 Forward Curved

4.1.2.2 Axial

4.1.2.3 Plenum

4.1.2.3.1 Single Plenum Fan

4.1.2.3.2 Plenum Fan Array

4.1.3 *Fan Drive Type.*

4.1.3.1 Belt Drive

4.1.3.2 Direct Drive

4.1.4 *Test Methods.*

4.1.4.1 Wire-to-Air Method. per Section 5.1.1

4.1.4.2 Fan Shaft Power (H_{act}) and Calculation of FEP per Section 5.1.2

Section 5. Test Requirements

5.1 *Test Methods.* Acceptable test methods are described in Sections 5.1.1 and 5.1.2.

5.1.1 *Electrical power Measurement Wire-to-Air Method.* All Published Ratings shall be from testing conducted in accordance with AMCA Standard 210 and ASHRAE Standard 51. Electrical power shall either be measured by one of the two following methods:

5.1.1.1 Electrical power shall be measured at all airflows and pressures at which the CSAHU will be offered for sale.

5.1.1.2 Interpolations shall be performed per the requirements of Appendix G of this standard for calculation of electrical power measurement ratings at non-tested speeds and conditions.

5.1.2 *Fan Shaft Power and Calculation of FEP by AMCA Standard 207 Method.* For CSAHUs that include motors, transmissions, and optional Motor Controllers that meet the requirements of AMCA Standard 207, all Published Ratings shall be from fan shaft power testing conducted in accordance with AMCA Standard 210 and ASHRAE Standard 51 with FEP calculated per the requirements of AMCA Standard 207.

5.2 *Duct Arrangement*

5.2.1 *Single Outlet Ducted Fan Discharge CSAHUs.* Single outlet Ducted Fan Discharge CSAHUs shall be tested in accordance with AMCA Standard 210 and ASHRAE Standard 51.

5.2.2 *Multiple Outlet Ducted Fan Discharge CSAHUs.* Multiple outlet Ducted Fan Discharge CSAHUs shall be tested as described in Section 5.2.1 with each fan outlet ducted as shown in Figure 3 to the airflow measuring test setup. No corrections for individual fan outlet duct friction losses shall be made.

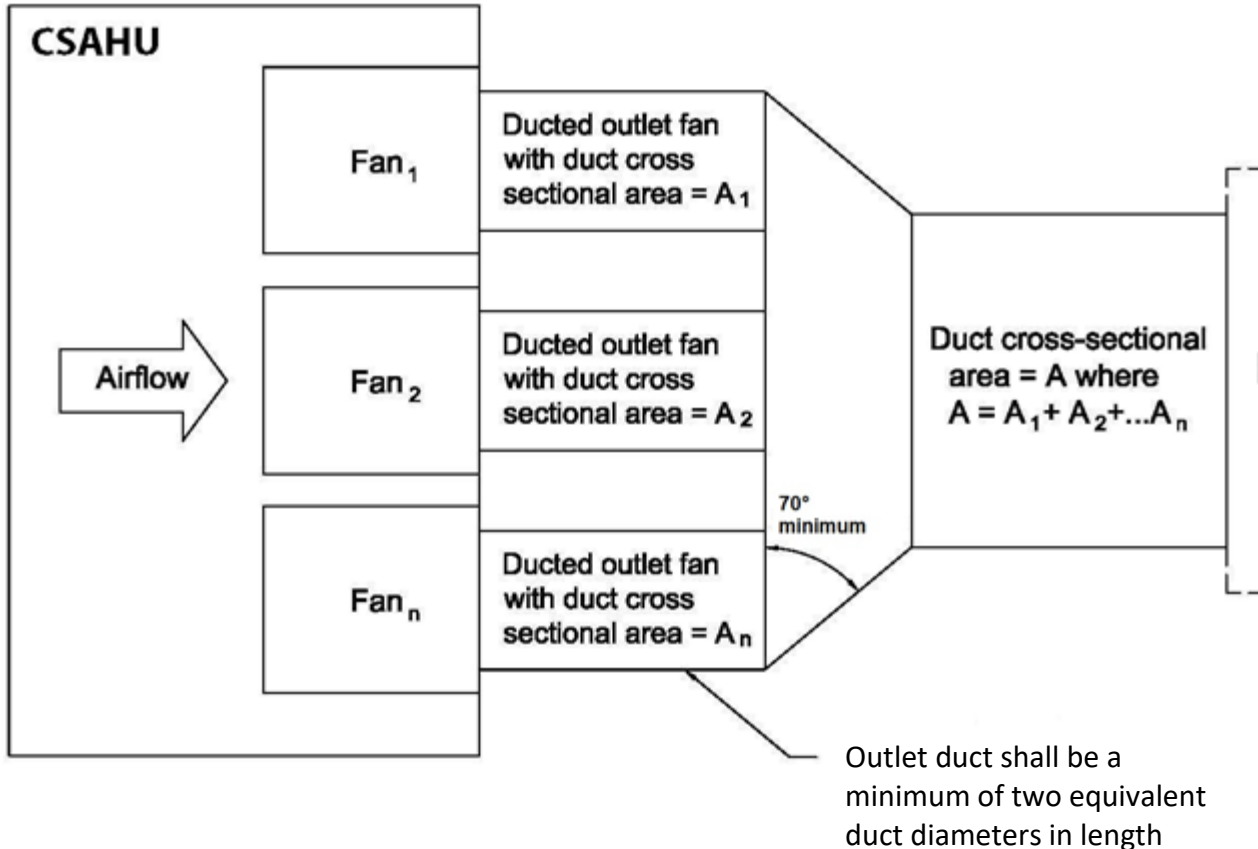

Figure 3. Outlet Test Unit Configuration for Multiple Parallel Housed Fans in CSAHUs with Individual Ducted Discharges

5.2.3 Unducted Fan Discharge CSAHUs. Unducted Fan Discharge CSAHUs shall be tested in accordance with AMCA Standard 210 and ASHRAE Standard 51, except when an outlet chamber with multiple nozzles within the chamber is used. If an outlet chamber with multiple nozzles within the chamber is used, the test chamber cross-sectional area shall be sized so that the maximum air velocity does not exceed 400 fpm. The test chamber height and width shall be at least 5% greater than the respective height and width of the duct connection at the test chamber. Discharge area cannot exceed the test chamber area. For an example, see Figure 4. Corrections for static pressure losses created by the test apparatus (e.g. the addition of ductwork) shall be made according to Appendix E and the ASHRAE Duct Fitting Database.

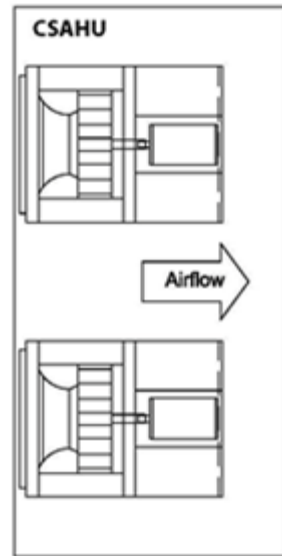

Figure 4. Single Outlet Test Unit Configuration for Single or Multiple Parallel Plenum Fans in CSAHUs with Full Face Opening Axial Discharge

5.3 Fan Types

5.3.1 Plenum Fan Units. The rating configuration for Plenum Fan units shall be Full Face Opening Axial Discharge with the minimum spacing allowed per the manufacturer's specifications between the coil and the fan. If Full Face Opening Axial Discharge is not possible due to the size of the unit compared to the test chamber, the unit shall be provided with an inlet or discharge plenum and the duct length shall be specified by the manufacturer but not exceed 3 duct diameters. Corrections for static pressure losses created by the test apparatus (e.g. the addition of ductwork) shall be made according to Appendix E and the ASHRAE Duct Fitting Database. The discharge or inlet plenum shall be considered as an Appurtenance to the CSAHU for the purpose of testing. The figure in AMCA 210 titled "Inlet Chamber Setup – Multiple Nozzles in Chamber" shall be used for the test set-up of Belt Drive Plenum Fan units (see Figure 5). Figures 5 or 6 shall be used for the test set-up of Direct Drive Plenum Fan units.

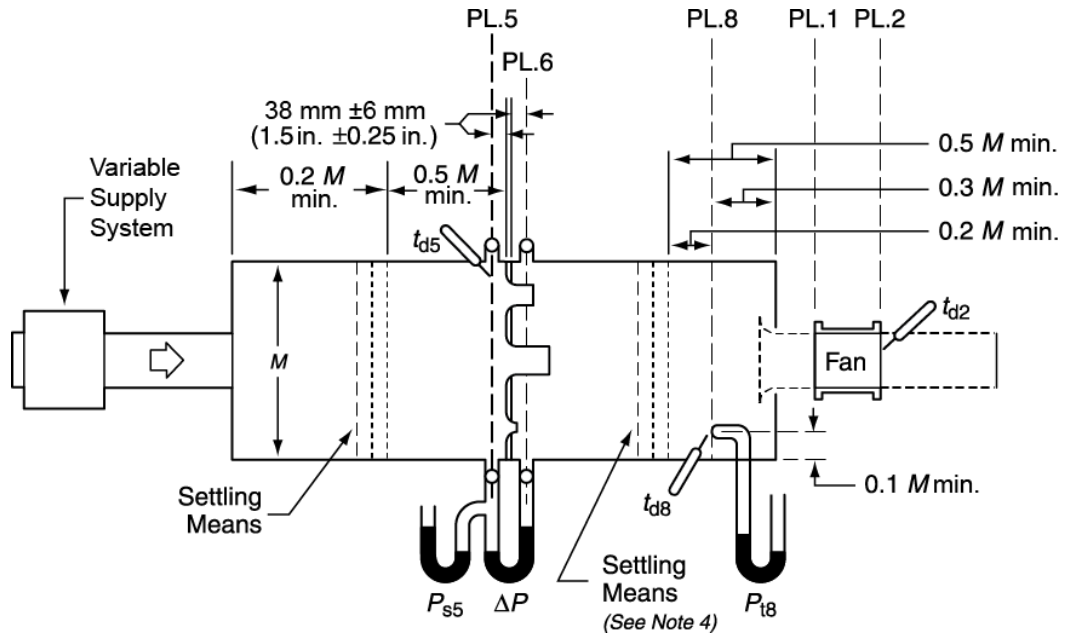

Figure 5. Inlet Chamber Setup – Multiple Nozzles in Chamber

(Figure 5 source: ANSI/AMCA 210-16; Copyright AMCA 2016. Reproduced by permission.)

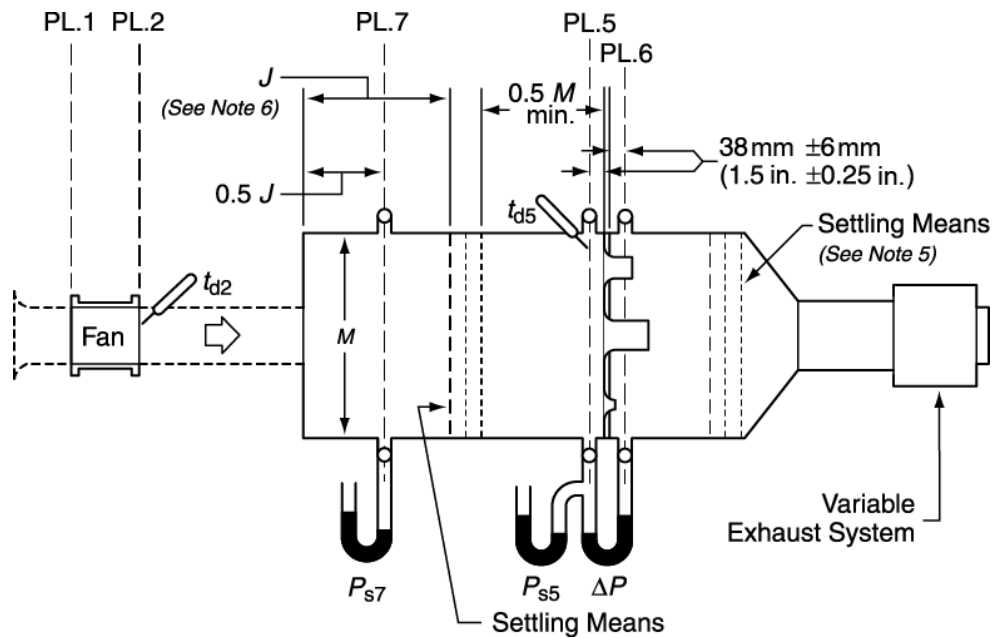

Figure 6. Outlet Chamber Setup – Multiple Nozzles in Chamber

(Figure 6 source: ANSI/AMCA 210-16; Copyright AMCA 2016. Reproduced by permission.)

5.3.2 *Units with Direct Drive Fans*

5.3.2.1 The shaft power measurement for units with Direct Drive Supply Fans shall be either calibrated motor (as defined in the section of AMCA 210 titled “Calibrated Motor”) or reaction dynamometer (as defined in the section of AMCA 210 titled “Reaction Dynamometers”).

5.3.2.2 The electrical power measurement for units with Direct Drive Supply Fans shall be made using a power meter with an accuracy of $\pm 0.5\%$ of the indicated value.

5.3.3 *Units with Belt-drive Fans*

5.3.3.1 The shaft power measurement for units with Belt Drive Supply Fans shall be reaction dynamometer (as defined in the section of AMCA 210 titled “Reaction Dynamometers”).

5.3.3.2 The electrical power measurement for units with Belt Drive Supply Fans shall be made using a power meter with an accuracy of $\pm 0.5\%$ of the indicated value.

5.3.4 *Units with Fan Arrays.* The rating configuration for units with Fan Arrays shall be Full Face Opening Axial Discharge with the minimum spacing allowed per the manufacturer’s specifications between the coil and the fan. If Full Face Opening Axial Discharge is not possible due to the size of the unit, the unit shall be provided with an inlet or discharge plenum and a suitably sized duct shall extend from the plenum. Corrections for static pressure losses created by the test apparatus (e.g. the addition of ductwork) shall be made according to Appendix E and the ASHRAE Duct Fitting Database. The discharge or inlet plenum shall be considered as an Appurtenance to the CSAHU for the purpose of testing.

5.3.4.1 *Fan Shaft Power Method.* The shaft power determination for units with Fan Arrays shall use the calibrated motor method as defined in Section 4.4.3 of AMCA 210. (Optional)

5.3.4.1.1 The minimum number of motors to be calibrated shall be as specified in Table 1.

Table 1. Number of Motors to be Calibrated ¹	
Number of Supply Fans in the Fan Array	Number of Motors to be Calibrated
2-4	2
5-8	3
9-12	4
13+	5
Notes: 1) An equal distribution of Contained and Uncontained Fans must be measured.	

5.3.4.1.1.1 Refer to NEMA MG-1 for acceptable tolerances between motor calibrations. If the requirements in NEMA MG-1 are not met, then all motors shall be calibrated.

5.3.4.1.2 Motor calibrations shall be performed at the same frequency and voltage output as used during the test.

5.3.4.1.3 Average the calibrated motors to get the composite motor calibration.

5.3.4.1.3.1 To get the average composite motor calibration, create a scatterplot of the data and use simple linear regression to find the equation for the line fit in slope-intercept form.

5.3.4.1.3.1.1 Alternatively, a polynomial regression can be computed to improve accuracy instead of a linear regression.

5.3.4.1.4 During the test, measure total power input after the VFD/controller.

5.3.4.1.4.1 If unable to measure total power input after the VFD/controller, measurements shall be simultaneously recorded for the power input into all individual motors to get the total power input.

5.3.4.1.4.2 Shaft power is calculated following the procedure shown below. An example is shown in Appendix D.

5.3.4.1.4.2.1 Divide the total input power by the number of Operating Fans.

5.3.4.1.4.2.2 Determine the shaft power per fan using the composite motor calibration data.

5.3.4.1.4.2.3 Multiply the shaft power per fan by the number of fans to get the total unit shaft power.

5.4 *Electrical Power Measurement Method.* Total power consumed must be measured or modeled. The minimum number of Power Connections to be measured for units with Fan Arrays shall be determined by Table 2 below.

Table 2. Minimum Number of Power Connections to be Measured¹	
Number of Power Connections in the Fan Array	Number of Points to be Monitored
1-5	Equal to number of Power Connections
6+	5 or more
Notes: 1) An equal distribution of Contained and Uncontained Fans must be measured.	

5.4.1 *Non-fan system components.* Any components that draw power from the same Power Connection(s) that are not part of the Fan System under test and are not necessary for the operation of the fans shall be turned off.

5.4.2 *Power measurement with Motor Controllers.* If one or more Motor Controllers is supplied with the unit, the power measurement shall be taken upstream of each Motor Controller.

5.4.3 *Calculation of Electrical power*

5.4.3.1 *All Power Connections monitored.* If all Power Inputs of the Fan System are monitored, the FEP is the sum of all the measurements.

5.4.3.2 If multiple Power Connections are provided, and each Power Connection serves an identical fan, motor and controller, then not all Power Connections must be measured as allowed by Sections 5.4.3.2.1 and 5.4.3.2.2.

5.4.3.2.1 If the highest measured electrical input power is not more than 3% greater than the lowest measured electrical input power, then the mean of the electrical input power of the Operating Fans shall be used to represent the electrical input power of each unmonitored Power Input. The measured and calculated electrical input powers shall be summed. If the 3% tolerance is not met, follow the procedure in Section 5.4.3.2.2.

5.4.3.2.2 If the highest electrical input power is more than 3% greater than the lowest electrical input power, record the electrical input power for each monitored Power Connection. Repeat the test with the previously unmonitored Power Connection monitored. Repeat the test until there is a measured electrical input power for each Power Connection and sum the values.

5.5 *Description of Test Unit.* The test unit shall have an internal pressure drop of at least 0.020 kPa at the rated airflow.

5.6 *Extension of Test Data.* In lieu of testing every configuration, it is acceptable to extend test data to other configurations in accordance with the provisions of the following subsections:

5.6.1 *Application of Fan Laws to Proportional Units with Proportional Fans.* Test data may be extended by use of the fan laws to units containing fans, geometrically proportional fan cabinets and impellers (Appendix C). The fan impeller diameter of the unit to be calculated shall not be less than 65% of the fan impeller diameter of the test unit. Note that fan laws are not applicable to fan input power measurements.

5.6.1.1 Fans are considered proportional when:

5.6.1.1.1 Impeller width, housing development radii, and housing width are proportional within $\pm 1.5\%$.

5.6.1.1.2 Fan Housing outlet area is proportional within $\pm 3\%$.

5.6.1.2 Fan cabinets are considered proportional when:

5.6.1.2.1 The clearance between the cabinet and the nearest Fan Housing are proportional or greater.

5.6.1.2.2 The clearance between adjacent Fan Housings, as measured parallel to the fan shaft, is proportional or greater.

5.6.1.2.3 The fan cabinet inlet and the fan cabinet outlet airflow cross sectional areas are not less than 92.5% of the respective geometrically proportionate values.

5.6.1.2.4 Arrangement and location of internal bearings and their supports, motors and drives, shall result in net airflow areas not less than 92.5% of those derived from exact proportionality when located within 0.5 impeller diameter of the fan inlet.

5.6.1.3 The basis for proportionality in every case shall be the respective impeller diameters. Linear dimensions shall be proportional to the diameter and areas shall be proportional to the square of the diameter.

5.6.1.4 Single fan units may be rated from the test of a multiple fan unit, provided that the units are otherwise proportional and that the clearance between fans on the multiple fan unit is not more than twice the proportionate clearance between the cabinet and the Fan Housing on a single fan unit. In no case, shall the ratings of a multiple fan unit from tests of a single fan unit be accepted. Airflow and fan shaft power or fan assembly electrical power-are considered to be proportional to the number of fans when all fans are equal size

5.6.1.5 Ducted Fan Discharge CSAHUs which have a change in airflow direction between the coil and the fan (Figure 7) may be rated from tests of units which do not have this flow direction change provided the plenum causing the air direction change be considered an Appurtenance and the effect of its application added to those of other Appurtenances as provided in Section 6.1.1. There is no distinction in rating between a vertical discharge and a horizontal discharge of Unducted Fan Discharge CSAHUs.

5.6.1.6 The effects of bolts, nuts, rivets, etc. on proportions, shall be considered negligible.

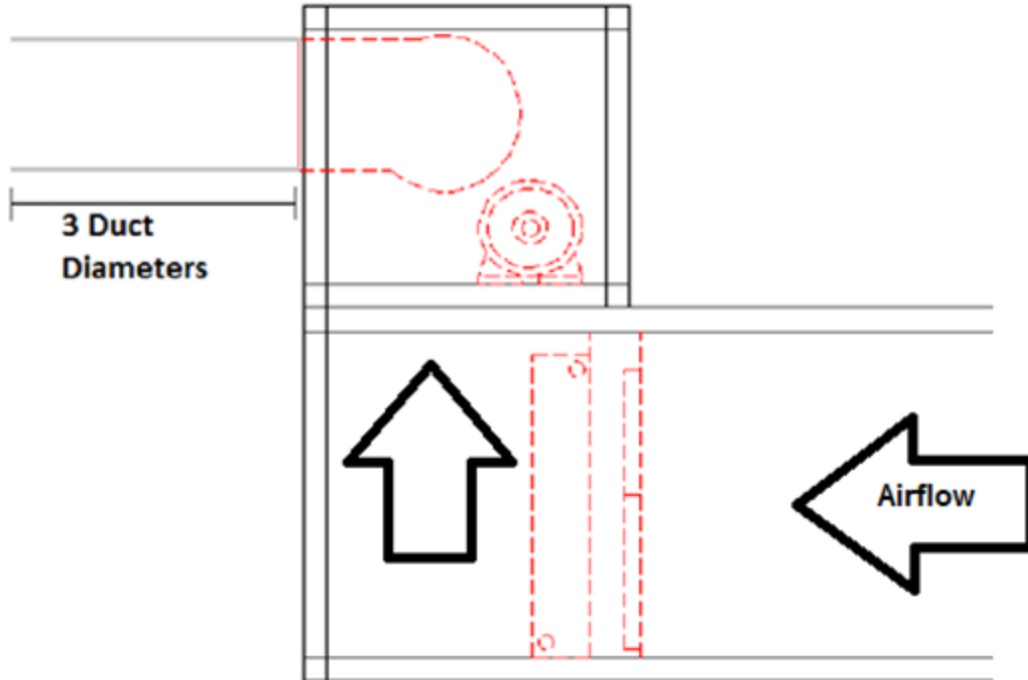

Figure 7. Ducted Fan Discharge CSAHU with Airflow Direction Change

5.6.2 *Application of Fan Laws to Proportional Units with Non-proportional Fans.* The requirements for proportional fan impellers and scrolls set forth in Section 5.6.1 are waived when all fans which are not geometrically proportional are rated as fans alone on the basis of tests performed in accordance with AMCA Standard 210 and ASHRAE Standard 51. This applies only to fans of the same blade design. Backward inclined fan impellers are not considered to be the same design as airfoil impellers. All other requirements of Section 5.6.1 shall be met.

5.6.2.1 The method of rating one unit from the test of another is as follows:

5.6.2.1.1 Using the rating performance curve of the fan alone or the unit, create non-dimensional performance curves including percentage wide open airflow rate, m^3/s , percentage blocked tight static pressure and percentage wide open fan shaft power, W, or electrical input power, kW. (Figure 8).

5.6.2.1.2 To derive the rating performance curve for the test unit without coil, add the test unit static pressure data to the static resistance of the dry coil as determined in accordance with AHRI Standard 410 (Figure 8).

5.6.2.1.3 Superimpose on Figure 8 the unit rating performance curve as derived under Section 5.6.2.1.2 at the same rpm, expressing the values in percentages of wide open airflow rate, m^3/s , blocked tight static pressure, kPa, and wide open fan shaft power, W, or electrical input power, kW, of the fan alone or unit (Figure 8).

5.6.2.1.4 For the unit which is to be rated, but not tested, (Figure 9) use the rating performance curve of the fan alone or unit and plot percentages of wide open m^3/s , blocked tight static pressure kPa and wide open fan shaft power, W, or electrical input power, kW, in the same way as for the solid line curve in Figure 8.

5.6.2.1.5 Adjust the curves in Figure 8 by the performance corrections between pairs of curves as indicated in Figure 9. The resultant curves are the calculated performance ratings for the unit not tested, expressed in percentages of performance of the fan alone or unit (dashed lines in Figure 9).

5.6.2.1.6 To determine the actual rating performance values for the specific unit, multiply the percentage values by the wide open airflow rate, m^3/s , blocked tight static pressure and wide open fan shaft power, W, or electrical input power, kW, of the specific unit's fan alone or specific unit at the same rpm as in Figure 8 performance curves.

5.6.2.1.7 The same procedure as for Section 5.6.2.1.7 applies to multiple fan units, except that the airflow rate, m^3/s , and fan shaft power, W, or electrical input power, kW, values for the fan alone are multiplied by the number of fans before applying to the unit, with the restrictions shown in 5.6.1.1. Single fan units may be rated from the tests of multiple fan units, but multiple fan units shall not be rated from tests of single fan units.

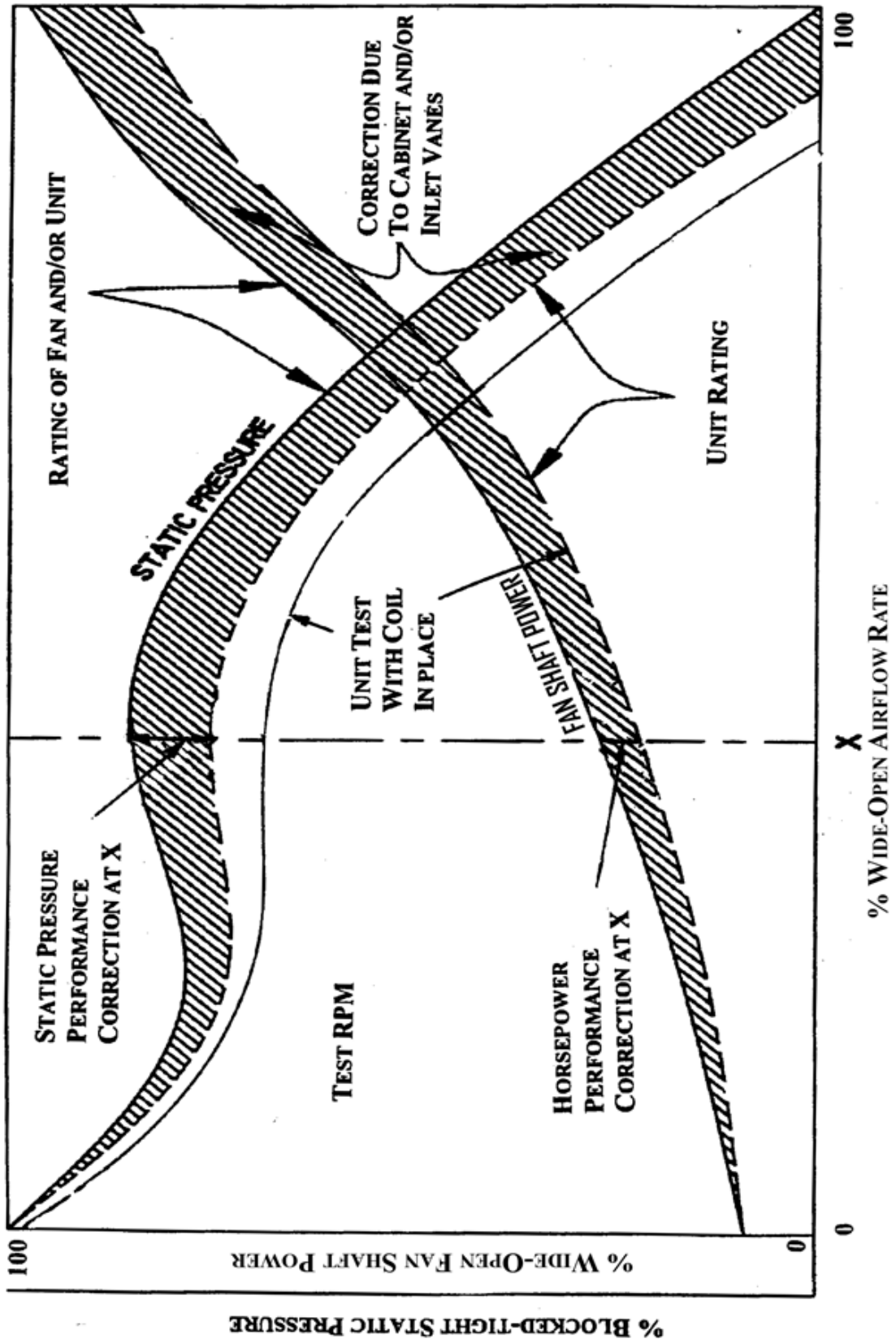

Figure 8. Fan and Unit Characteristics – Fan Rated and Unit Tested
 Note: All Percentages Refer to Fan Along with or without Inlet Vanes and/or Unit without Inlet Vanes

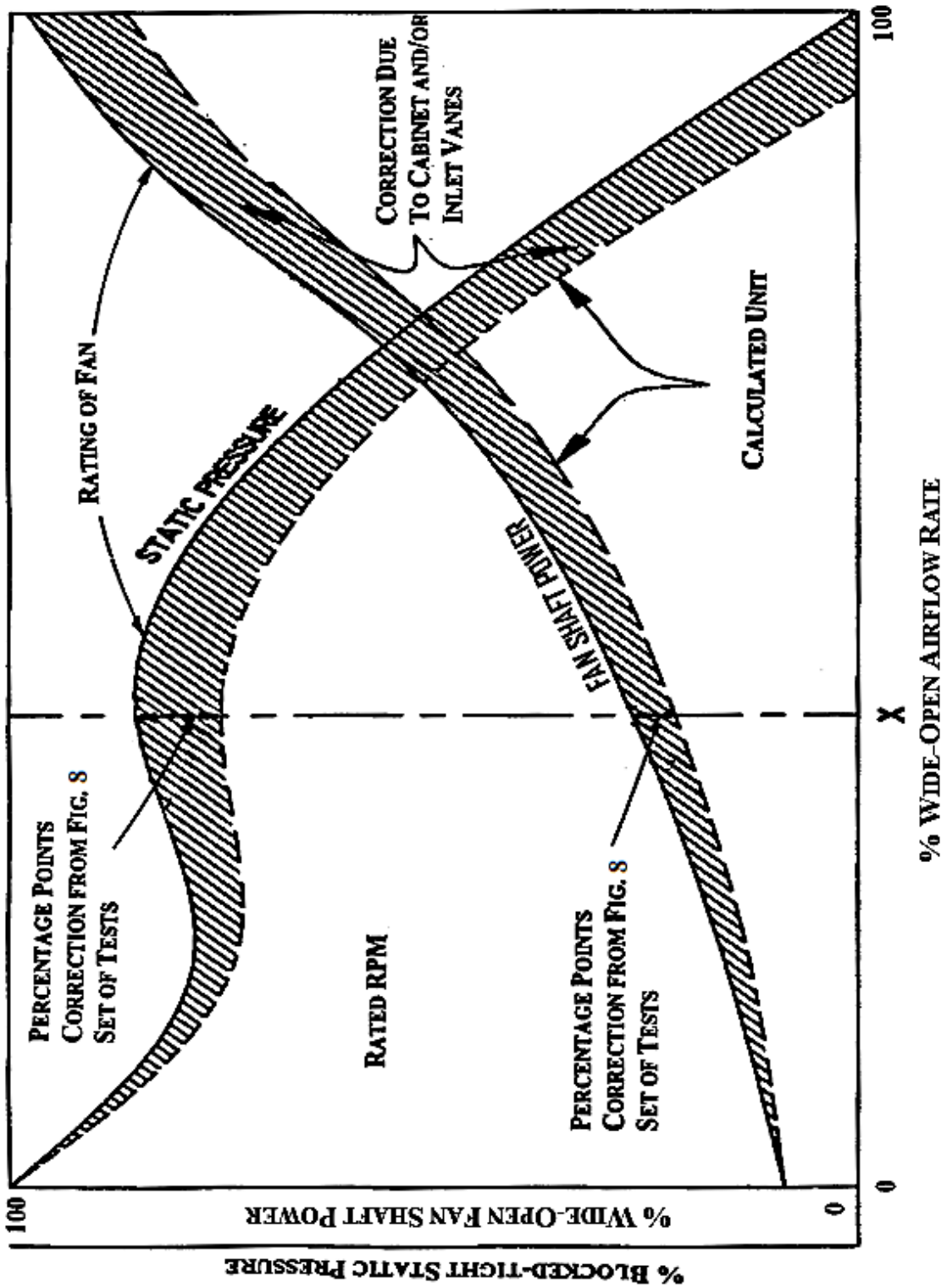

Figure 9. Fan and Unit Characteristics – Fan Rated and Unit Calculated
 Note: All Percentages Refer to Fan Alone with or without Inlet Vanes and/or Unit without Inlet Vanes.

Section 6. Rating Requirements

6.1 Air-handling Ratings. Published air-handling ratings represent the performance of the fan section alone without Appurtenances and shall be expressed in terms of the airflow rate, Actual m^3/s , static pressure, kPa (corrected for Standard Air), fan speed, rev/s, FEP, kW, and fan shaft power, kW, (only if reported and corrected for Standard Air), based on the procedures outlined in Sections 5.1.1 and 5.1.2 of this standard.

6.1.1 Appurtenances. The effects of non-rated Appurtenances included as part of the CSAHU shall be taken into account in order to establish the overall performance of the combined unit. These effects shall be provided by the manufacturer and stated in terms of pressure drop, kPa, measured across the Appurtenance over the range of air quantities for which the unit is rated.

6.2 Tolerances. To comply with this standard, the following tolerances shall apply:

6.2.1 Measured Fan Speed, rpm, shall not exceed 105% of Published Rating.

6.2.2 For units rated in accordance with Section 5.1.1, the measured power shall not exceed 110% of published rated power when operated between 75%-125% of nameplate motor speed and 75%-100% of nameplate motor power. The measured electrical power shall not exceed 112.5% for all other conditions.

6.2.3 For units rated in accordance with Section 5.1.2, or if fan shaft power, kW, is reported, it shall not exceed 107.5% of Published Rating at the published volume and pressure.

Section 7. Symbols and Subscripts

7.1 Symbols and Subscripts. The symbols and subscripts used in this standard are as follows:

A	Combined area of individual fan outlets, m^2
$A_1, A_2, \dots A_n$	Area of individual fan outlets, m^2
A_t, A_v	Area of individual fan outlet (as used in Appendix C), m^2
C	Closest distance from inside wall to entering plane of inlet cone (Housed Centrifugal Fans only), cm
D	Distance from opposite side wall to entering plane of opposite inlet cone (Housed Centrifugal Fans only), cm
D_1	Impeller diameter measured at the blade outer tip, m
D_2	Inlet cone diameter at inlet edge of cone for all fan types, m
D_t, D_v	Impeller diameter of unit (as used in Appendix C), m
$E_{1,2,n}$	For multiple parallel fans, distance from the fan shaft centerline to the adjacent fan shaft centerline (Plenum and Axial Fans) or distance from the inlet plane of one fan to the inlet plane of the adjacent fan (Housed Centrifugal Fans), m
FEP_{act}	Actual FEP, kW
G, G_t, G_v	Internal cabinet height from top of bottom or floor to inside of top panel, (as used in Appendix C), m
H_1	Closest vertical dimension from fan wheel outside diameter to inside of cabinet, cm
$H_{m,act}$	Motor Output Power, kW
$H_{i,act}$	Fan Shaft Power, kW
$H_{sh,f}$	Shaft power of each fan in Fan Array within CSAHU, W
$H_{sh,o}$	Overall shaft power of CSAHU, W
J, J_t, J_v	Perpendicular distance from top of fan cutoff to inside of top discharge duct surface (as used in Appendix C), cm
K, K_t, K_v	Height of the housed opening from inside of Fan Housing surface to inside of opposite Fan Housing surface measured at the outlet plane of the Fan Housing, (as used in Appendix C), m
K_w	Width of the housed opening from inside of Fan Housing surface to inside of opposite Fan Housing surface measured at the outlet plane of the Fan Housing, m
L_1	Closest horizontal dimension from fan wheel outside diameter to inside of the cabinet, cm

L_i	Closest distance from coil leaving face to fan inlet plane for Housed Centrifugal Fans and Plenum Fans, m (For Housed Centrifugal Fans, it is the distance from coil leaving face to the centerline of the fan shaft)
L_o	Distance from Axial Fan exit plane or Plenum Fan hub-plate to downstream heat exchanger entering face, m (For Housed Centrifugal Fan, it is the distance from the fan discharge face to the downstream heat exchanger entering face.)
LD_t, LD_v	Linear dimension of unit (as used in Appendix C), m
M, M_t, M_v	Fan wheel width (as used in Appendix C), m
n	Number of outlets
n_f	Total number of fans in Fan Array
N	Interpolated fan speed, rev/s
N_{high}	Fan speed of the higher speed test, rev/s
N_{low}	Fan speed of the lower speed test, rev/s
P	Interpolated fan total or fan static pressure, kPa
P_{high}	Pressure from higher speed test, kPa
P_{low}	Pressure from lower speed test, kPa.
Q	Interpolated airflow, m^3/s
Q_{high}	Airflow from the higher speed test, m^3/s
Q_{low}	Airflow from the lower speed test, m^3/s
$R_{max,t}, R_{max,v}$	Maximum fan housing radii, (as used in Appendix C), m
$R_{min,t}, R_{min,v}$	Minimum fan housing radii, (as used in Appendix C), m
S, S_t, S_v	Discharge opening height from inside of top of discharge duct surface to inside of bottom duct surface measured at the outlet plane of the unit (as used in Appendix C), m
t	Refers to a unit with tested performance rating
T, T_t, T_v	Discharge opening width from inside of side of discharge duct surface to inside of opposite side discharge duct surface measured at the outlet plane of the unit, m
v	Refers to a unit with calculated performance rating
w, w_t, w_v	Internal cabinet width from inside of panel to opposite inside of panel (as used in Appendix C), ft
W	Interpolated fan electrical input power, W or kW
W_f	Electrical input power per fan in Fan Array within CSAHU, kW
W_{high}	FEP value of the higher speed test, W or kW
W_{low}	FEP value of the lower speed test, W or kW
W_o	Overall electrical input power to CSAHU, kW
η_{max}	Maximum efficiency of the corresponding test point of either the lower or higher test speed W/W
$\eta_{transmission}$	Transmission efficiency
$\eta_{motor+control}$	Motor and control efficiency
$\eta_{motor+control+transmission}$	Combined efficiency of motor, control, and transmission
ρ	Interpolated fan air density, kg/m^3
ρ_{std}	Density of Standard Air, $1.2 kg/m^3$
θ	Angle from centerline of fan shaft to centerline of rotation of inlet vane, degrees

Section 8. Minimum Data Requirements for Published Ratings

8.1 *Minimum Data Requirements for Published Ratings.* As a minimum, Published Ratings shall include all information in section 8.2. All claims to ratings within the scope of this standard shall include the statement "Rated in accordance with AHRI Standard 431 (SI)". All claims to ratings outside the scope of this standard shall include the statement "Outside the scope of AHRI Standard 431 (SI)". Wherever Application Ratings are published or printed, they shall include a statement of the conditions at which the ratings apply.

8.2 *Published Ratings.* Published Ratings (in catalogs or as computer output) shall include, or be capable of generating, unit designation(s), and the information below.

8.2.1 Static Pressure, kPa

8.2.2 Airflow Rate, Actual m³/s

8.2.3 Fan Speed, rev/s

8.2.4 FEP, kW. (Shall note which method was used per Section 5.1)

8.2.5 Fan Shaft Power, W. (if tested according to Sections 5.1.2 or 5.3.4.1)

Section 9. Marking and Nameplate Data

9.1 *Marking and Nameplate Data.* As a minimum, the nameplate shall display the manufacturer's name and model designation.

If the nameplate shows electrical characteristics, then nameplate voltages for 60 Hz systems shall include one or more of the equipment nameplate voltage ratings shown in Table 1 of AHRI Standard 110. Nameplate voltages for 50 Hz systems shall include one or more of the utilization voltages shown in Table 1 of IEC Standard 60038.

Section 10. Conformance Conditions

10.1 *Conformance.* While conformance with this standard is voluntary, conformance shall not be claimed or implied for products or equipment within the standard's *Purpose* (Section 1) and *Scope* (Section 2) unless such product claims meet all of the requirements of the standard and all of the testing and rating requirements are measured and reported in complete compliance with the standard. Any product that has not met all the requirements of the standard shall not reference, state, or acknowledge the standard in any written, oral, or electronic communication.

APPENDIX A. REFERENCES – NORMATIVE

A1 Listed here are all standards, handbooks and other publications essential to the formation and implementation of the standard. All references in this appendix are considered as part of the standard.

A1.1 AHRI Standard 110-2016, *Air-Conditioning and Refrigerating Equipment Nameplate Voltages*, 2016, Air-Conditioning, Heating, and Refrigeration Institute, 2311 Wilson Boulevard, Suite 400, Arlington, VA 22201, U.S.A.

A1.2 AHRI Standard 210/240-2017, *Performance Rating of Unitary Air-conditioning & Air-source Heat Pump Equipment*, 2017, Air-Conditioning & Refrigeration Institute, 2311 Wilson Boulevard, Suite 400, Arlington, VA 22201, U.S.A.

A1.3 AHRI Standard 340/360-2019, *Performance Rating of Commercial and Industrial Unitary Air-conditioning and Heat Pump Equipment*, 2019, American National Standards Institute and Air-Conditioning & Refrigeration Institute, 2311 Wilson Boulevard, Suite 400, Arlington, VA 22201, U.S.A.

A1.4 AHRI Standard 410-2001, *Forced-Circulation Air-Cooling and Air-Heating Coils with Addenda 1,2, and 3*, 2001, Air-Conditioning, Heating, and Refrigeration Institute, 2311 Wilson Boulevard, Suite 400, Arlington, VA 22201, U.S.A.

A1.5 AHRI Standard 440-2019, *Standard for Performance Rating of Fan-coil Units*, 2019, Air-Conditioning Heating & Refrigeration Institute, 2311 Wilson Boulevard, Suite 400, Arlington, VA 22201, U.S.A.

A1.6 AHRI Standard 840-2015, *Performance Rating of for Unit Ventilators*, 2015, American National Standards Institute and Air-Conditioning & Refrigeration Institute, 2311 Wilson Boulevard, Suite 400, Arlington, VA 22201, U.S.A.

A1.7 AHRI Standard 1210-2019, *Standard for Performance Rating of Variable Frequency Drives*, 2019 American National Standards Institute and Air-Condition & Refrigeration Institute, 2311 Wilson Boulevard, Suite 400, Arlington, VA, 22201, U.S.A.

A1.8 AHRI Standard 1360-2017, *Standard for Performance Rating of Computer and Data Processing Room Air Conditioners*, 2017, American National Standards Institute and Air-Condition & Refrigeration Institute, 2311 Wilson Boulevard, Suite 400, Arlington, VA, 22201, U.S.A.

A1.9 AMCA Publication 111-13, *Laboratory Accreditation Program*, 2013, Air Movement and Control Association International, Inc., 30 W. University Dr., Arlington Heights, IL, 60004, USA

A1.10 ANSI/AHRI Standard 920-2015, *Standard for Performance Rating of DX-Dedicated Outdoor Air System Units*, 2015, American National Standards Institute and Air-Condition & Refrigeration Institute, 2311 Wilson Boulevard, Suite 400, Arlington, VA, 22201, U.S.A.

A1.11 ANSI/AMCA Standard 210-16, *Laboratory Methods of Testing Fans for Certified Aerodynamic Performance Rating*, 2016, American National Standards Institute Air and Movement and Control Association, Inc., 30 West University Drive, Arlington Heights, IL 60004, U.S.A.

A1.12 ANSI/AMCA Standard 211-13, *Certified Ratings Program Product Rating Manual for Fan Air Performance (Rev. 10-18)*, 2013, American National Standards Institute and Air Movement and Control Association, Inc., 30 West University Drive, Arlington Heights, IL 60004, U.S.A.

A1.13 ANSI/ASHRAE Standard 51, *Laboratory Methods of Testing Fans for Certified Aerodynamic Performance Rating*, 2016, American National Standards Institute and American Society of Heating, Refrigerating, and Air-Conditioning Engineers, Inc., 11 West 42nd Street, New York, NY 10036, U.S.A./1791 Tullie Circle N.E., Atlanta, GA 30329, U.S.A.

- A1.14** ANSI/ASHRAE Standard 222-2018, *Standard Method of Test for Electrical Power Drive Systems*, 2018, American National Standards Institute and American Society of Heating, Refrigerating, and Air-Conditioning Engineers, Inc., 11 West 42nd Street, New York, NY 10036, U.S.A./1791 Tullie Circle N.E., Atlanta, GA 30329, U.S.A.
- A1.15** ASHRAE Terminology website (<https://www.ashrae.org/resources--publications/free-resources/ashrae-terminology>), 2019, American Society of Heating, Refrigerating and Air-Conditioning Engineers, Inc., 1791 Tullie Circle, N.E. Atlanta, GA 30329, U.S.A.
- A1.16** ASHRAE Duct Fitting Database Version 6.00.05, 2017, American Society of Heating, Refrigerating and Air-Conditioning Engineers, Inc., 1791 Tullie Circle, N.E. Atlanta, GA 30329, U.S.A.
- A1.17** ASHRAE Fundamentals, 2013, American Society of Heating, Refrigerating and Air-Conditioning Engineers, Inc., 1791 Tullie Circle, N.E. Atlanta, GA 30329, U.S.A.
- A1.18** CSA C747-2009 (R2014), 2009, *Energy Efficiency Test Methods for Small Motors*, Canadian Standards Association, 178 Rexdale Boulevard, Toronto, ON M9W 1R3, Canada.
- A1.19** CSA C838-2013 (R2018), 2013, *Energy Efficiency Test Methods for Three-Phase Variable Frequency Drive Systems*, Canadian Standards Association, 178 Rexdale Boulevard, Toronto, ON M9W 1R3, Canada.
- A1.20** IEC Standard 60038, *IEC Standard Voltages*, 2009, International Electrotechnical Commission, 3, rue de Varembe, P.O. Box 131, 1211 Geneva 20, Switzerland.
- A1.21** IEEE Standard 112-2017, *IEEE Standard Test Procedure for Polyphase Induction Motors and Generators*, 2017, Institute of Electrical and Electronics Engineers, 3 Park Avenue, 17th Floor, New York, NY 10016, U.S.A.
- A1.22** ISO/IEC 17025, *Testing and Calibration Laboratories*, International Organization for Standardization, Chemin de Blandonnet 8, CP 401 – 1214 Vernier, Geneva, Switzerland.

APPENDIX B. REFERENCES – INFORMATIVE

None.

APPENDIX C. CRITERIA FOR PROPORTIONALITY- INFORMATIVE

C1 This appendix sets forth procedures and equations that should be used to determine the proportionality requirements of CSAHUs as defined by this standard.

C2 *Basis of Proportionality.*

C2.1 The following denotes the type of CSAHU being rated:

C2.1.1 "t" refers to a unit with tested performance rating.

C2.1.2 "v" refers to a unit with calculated performance rating.

C2.2 Proportional linear dimensions (Figure C1-Figure C4) are determined using the generic Equation C1:

$$\frac{LD_v}{LD_t} = \frac{D_v}{D_t} \quad \text{C1}$$

C2.2.1 This ratio of the wheel diameters shall not be less than 0.65.

C2.3 Proportional areas (Figure C1-Figure C4) are determined using the generic Equation C2:

$$\frac{A_v}{A_t} = \left(\frac{D_v}{D_t}\right)^2 \quad \text{C2}$$

C3 Cabinet proportionality

C3.1 Linear dimensions C, D, E₁, E₂, G, J, K, L, M, S, T, w (Figure C1-Figure C4).

C3.1.1 The ratio of the rated unit linear dimension from the tested unit linear dimension shall be proportional within $\pm 1.5\%$.

$$\frac{LD_v}{LD_t} \geq \frac{D_v}{D_t} \quad \text{C3}$$

C3.2 *Areas.*

C3.2.1 *Fan Cabinet Air Inlet.*

$$\frac{G_v \cdot W_v}{G_t \cdot W_t} \geq 0.925 \cdot \left(\frac{D_v}{D_t}\right)^2 \quad \text{C4}$$

C3.2.2 *Fan Cabinet Air Outlet.*

$$\frac{S_v T_v}{S_t T_t} \geq 0.925 \cdot \left(\frac{D_v}{D_t}\right)^2 \quad \text{C5}$$

C3.2.3 The ratio of the rated unit area from the tested unit area shall be proportional within $\pm 3\%$.

C4 *Fan Proportionality.*

C4.1 *Proportional Linear Dimensions.*

C4.1.1 *Fan Wheel Width.*

$$\frac{M_v}{M_t} \geq \frac{D_v}{D_t} \quad \text{C6}$$

C4.1.2 *Fan Outlet Width.*

$$\frac{K_v}{K_t} \geq \frac{D_v}{D_t} \quad \text{C7}$$

C4.1.3 *Fan Housing Radii.*

$$\frac{R_{max,v}}{R_{max,t}} \geq \frac{D_v}{D_t} \quad \text{C8}$$

$$\frac{R_{min,v}}{R_{min,t}} \geq \frac{D_v}{D_t} \quad \text{C9}$$

C4.1.4 The ratio of the rated unit radial dimension from the tested unit radial dimension shall be proportional within $\pm 1.5\%$.

C4.2 *Proportional Areas.***C4.2.1** *Fan Outlet Area.*

$$\frac{J_v K_v}{J_t K_t} \geq \left(\frac{D_v}{D_t}\right)^2 \quad \text{C10}$$

C4.2.2 The ratio of the rated unit area from the tested unit area shall be proportional within $\pm 3\%$.

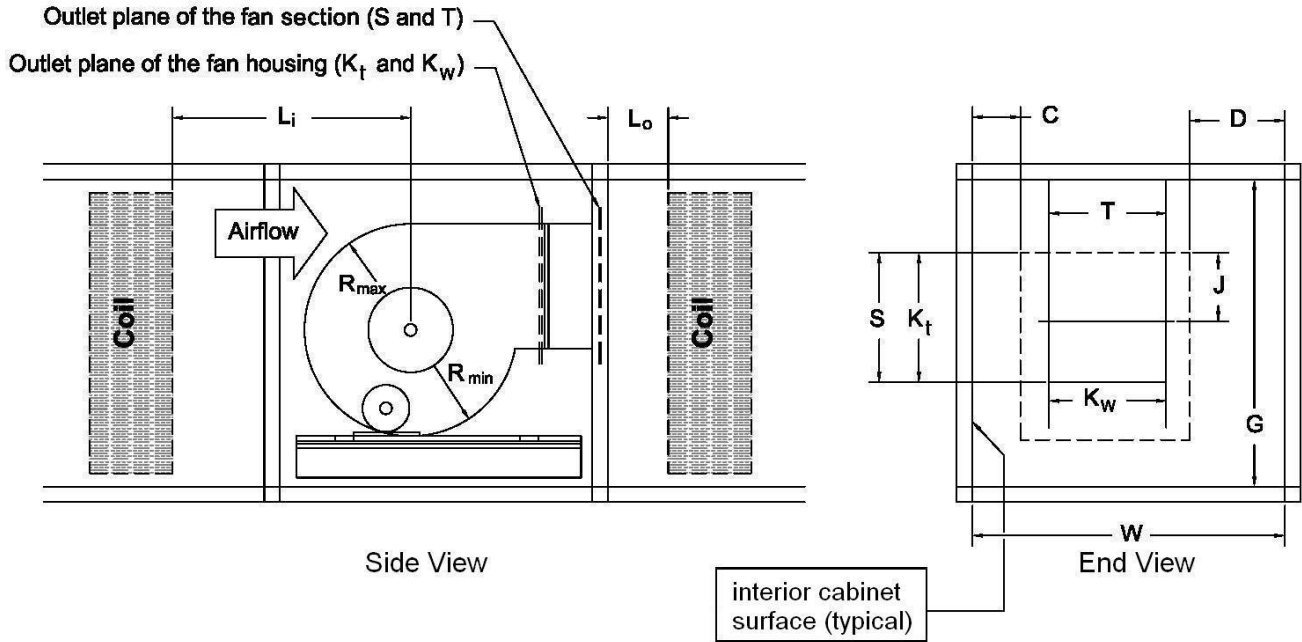

S and T are inside dimensions of the cabinet outlet. R_{min} and R_{max} are measured from the center of the shaft.

Figure C1. Dimensions Used for Proportionality Equations – Housed Fan

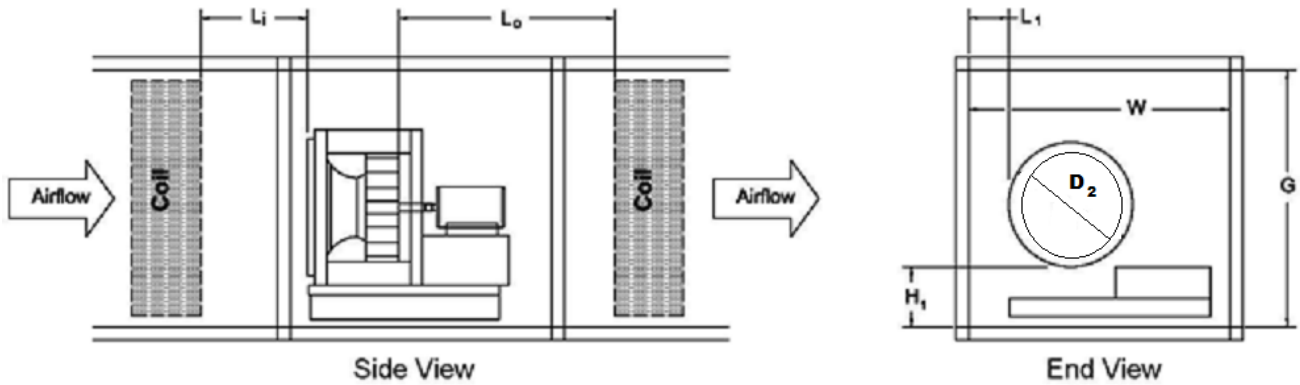

Figure C2. Dimensions Used for Proportionality Equations – Plenum Fan

Note: Contained Fan Arrays and Partially Contained Fan Arrays (for fans which do not aerodynamically interact) follow figure C2.

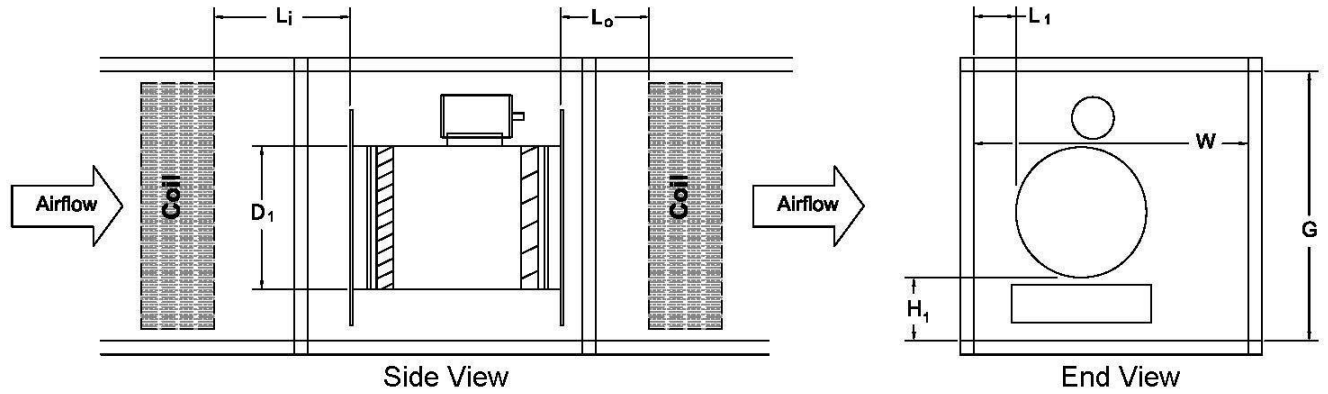
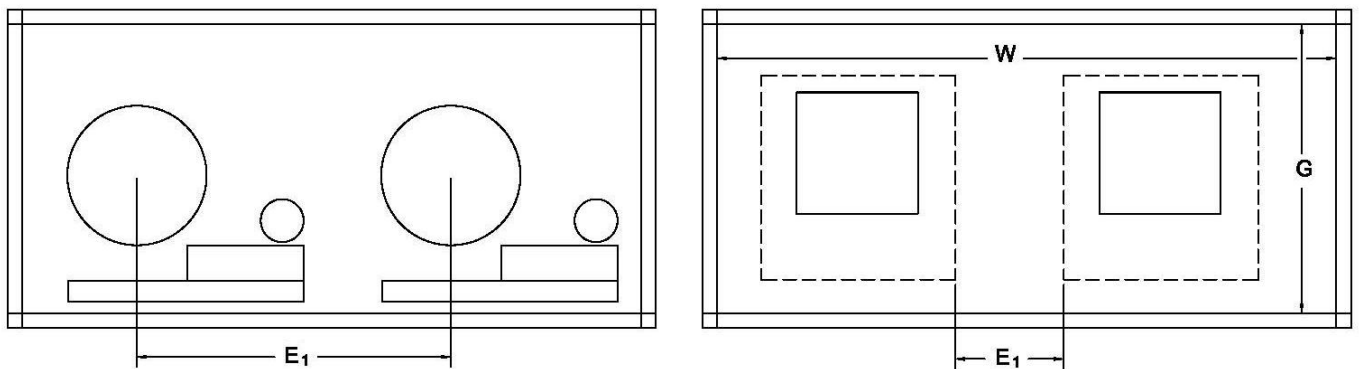

Figure C3. Dimensions Used for Proportionality Equations – Axial Fan



Plenum (shown) and Axial Fans

DWDI Housed Fans

Figure C4. Dimensions Used for Proportionality Equations – Multiple Fans (End Views)

Note: Uncontained Fan Arrays and Partially Contained Fan Arrays (for fans which aerodynamically interact) follow Figure C4.

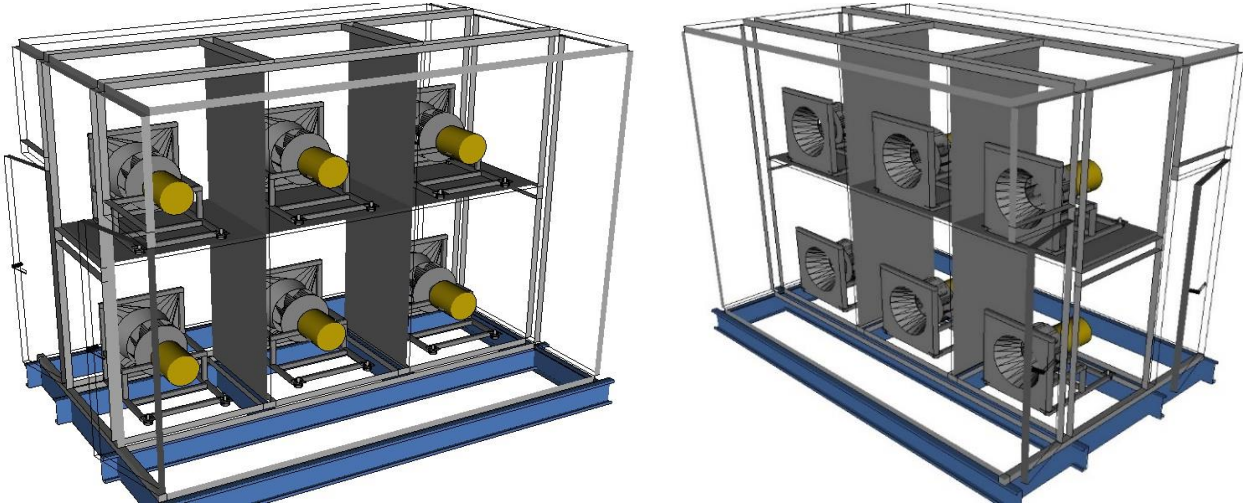

Figure C5. Example Contained Fan Array

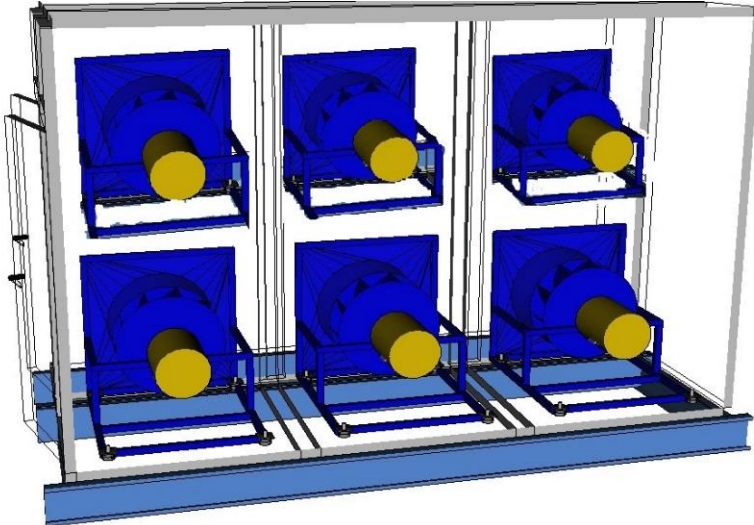

Figure C6. Example Uncontained Fan Array

APPENDIX D. EXAMPLE FAN ARRAY CALCULATION – INFORMATIVE

D1 The data shown in Table D1 was taken from a 2x2 Fan Array with four pole motors. The motor calibration was performed at nominal frequency of 60 Hz. The first example will use the methodology where Table 1 is followed. For 4 Operating Fans in the array, 2 were measured.

Motor 1		Motor 2	
Electrical power [Watts]	Output power [hp]	Electrical power [Watts]	Output power [hp]
247.2	0.000	251.9	0.000
387.3	0.180	345.1	0.126
519.9	0.340	494.0	0.326
617.0	0.488	611.6	0.474
768.7	0.688	751.0	0.677
888.3	0.851	854.6	0.805
1050.0	1.062	1023.1	1.033
1143.0	1.182	1124.8	1.178
1279.4	1.358	1304.6	1.395
1380.0	1.495	1365.9	1.481

D1.1 The data in Table D1 was plotted using software and a trendline was added; the equation for the trendline is shown in Figure D1.

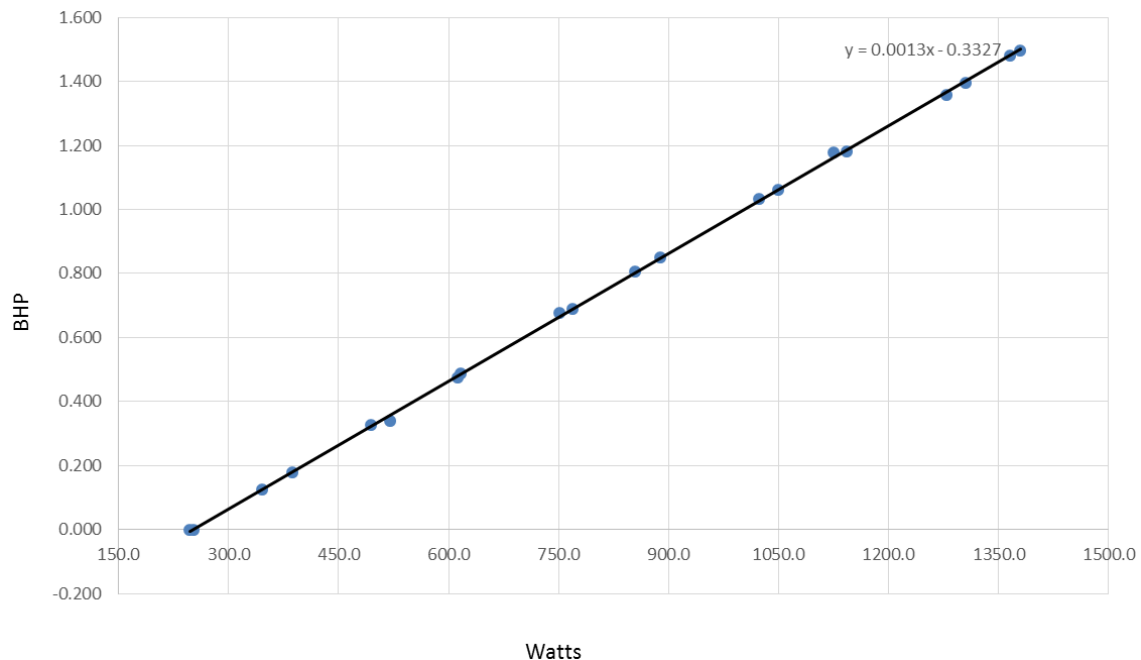

Figure D1. Example Scatterplot with Motor Calibration Data According to Table 1

D1.2 The total electrical input power measured was 3852.0 W according to AMCA 210. With 4 Operating Fans, the power input per fan calculates to 963.0 W using Equation D1. Using the formula found in the trendline (Equation D2), the shaft power per fan is calculated to be 0.9192 hp using Equation D3. Since there are 4 fans, the shaft power for the entire air handler can be determined using Equation D4 and is calculated to 3.6768 hp.

$$\frac{W_o}{n_f} = \frac{3852.0 W}{4} = 963.0 W \tag{D1}$$

$$H_{sh,f} = (0.0013 \cdot W) - 0.3327 \tag{D2}$$

$$H_{sh,f} = 0.0013 \cdot (W_f) - 0.3327 = (0.0013 \cdot 963.0) - 0.3327 = 0.9192 hp \tag{D3}$$

$$H_{sh,o} = H_{sh,f} \cdot (n_f) = 0.9192 \cdot 4 = 3.6768 hp \tag{D4}$$

D2 The data shown in Table D2 was taken from a 2x2 Fan Array with four pole motors. The motor calibration was performed at nominal frequency of 60 Hz. This example has all 4 fans being measured .

Motor 1		Motor 2		Motor 3		Motor 4	
Electrical power [Watts]	Output power [hp]	Electrical power [Watts]	Output power [hp]	Electrical power [Watts]	Output power [hp]	Electrical power [Watts]	Output power [hp]
247.2	0.000	251.9	0.000	249.4	0.000	249.2	0.000
387.3	0.180	345.1	0.126	387.8	0.183	353.4	0.120
519.9	0.340	494.0	0.326	509.7	0.354	487.1	0.303
617.0	0.488	611.6	0.474	636.5	0.520	603.8	0.463
768.7	0.688	751.0	0.677	780.2	0.722	722.2	0.619
888.3	0.851	854.6	0.805	897.0	0.871	861.4	0.808
1050.0	1.062	1023.1	1.033	1009.7	1.019	1001.4	0.990
1143.0	1.182	1124.8	1.178	1128.9	1.167	1130.5	1.159
1279.4	1.358	1304.6	1.395	1250.3	1.349	1244.9	1.315
1380.0	1.495	1365.9	1.481	1375.4	1.509	1386.9	1.506

D2.1 The data in Table D2 was plotted using software and a trendline was added; the equation for the trendline is shown in Figure D2.

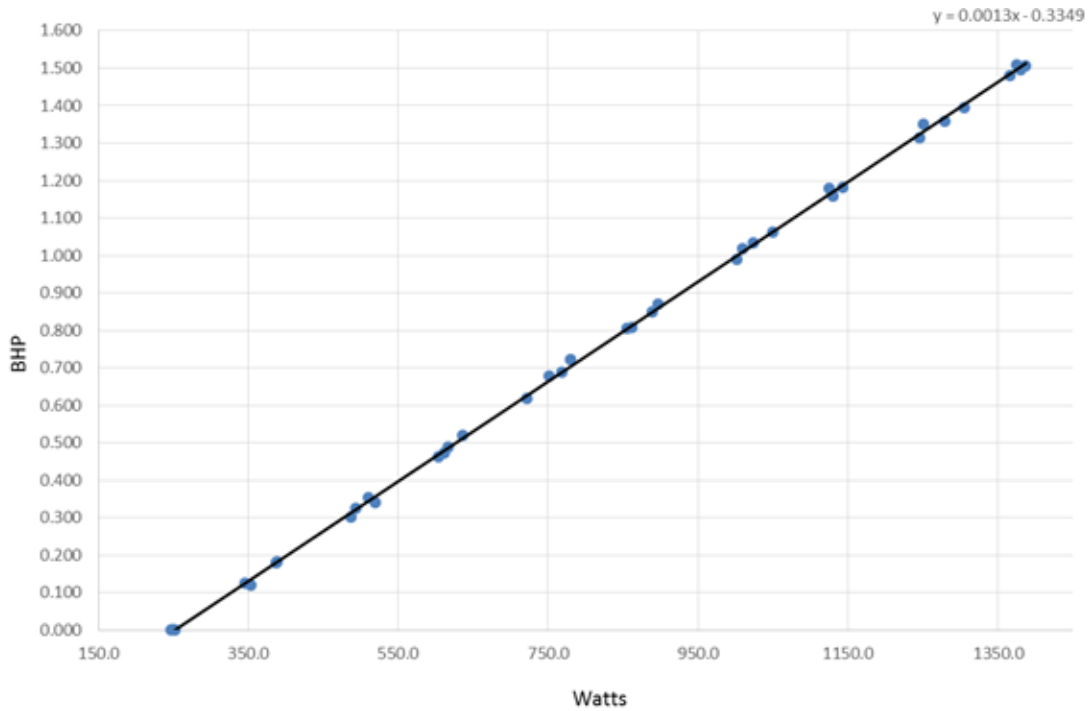

Figure D2. Example Scatterplot with Motor Calibration Data Not According to Table 1

D2.2 The total electrical input power-measured was 3852.0 W according to AMCA 210. With four Operating Fans, the power input per fan can be calculated using Equation D5 to be 963 W. Using the formula found in the trendline (Equation D6) in Figure D2, the shaft power per fan can be calculated using Equation D7 to be 0.917 hp. Since there are four Operating Fans, the total unit shaft power is calculated by Equation D8 to be 3.668 hp.

$$\frac{W_o}{n_f} = \frac{3852.0}{4} = 963.0 \text{ W} \quad \text{D5}$$

$$H_{sh,f} = (0.0013 \cdot W) - 0.3349 \quad \text{D6}$$

$$H_{sh,f} = 0.0013 \cdot (W_f) - 0.3349 = (0.0013 \cdot 963.0) - 0.3349 = 0.917 \text{ hp} \quad \text{D7}$$

$$H_{sh,o} = H_{sh,f} \cdot (n_f) = 0.917 \cdot 4 = 3.668 \text{ hp} \quad \text{D8}$$

APPENDIX E. CORRECTING FOR PRESSURE DROP THROUGH THE TEST EQUIPMENT FOR UNDUCTED DISCHARGE TESTS-NORMATIVE

E1 This appendix shows which air pressure losses created by the laboratory test equipment must be accounted for when testing units with inlet or discharge plenums either supplied by the manufacturer or constructed by the laboratory.

E2 *Definitions.*

E2.1 *Constructed by the Laboratory.* Any portion of the test set up that was not supplied by the manufacturer and was built solely to connect the unit to the test chamber for the purpose of the test. Any plenum extension shall have the same internal height and width as the test Unit Height and Unit Width.

E2.2 *Duct Dimensions.*

E2.2.1 *Duct Height (H_D).* The internal vertical dimension of the duct.

E2.2.2 *Duct Length (L_D).* The length of the duct between the test chamber and either the inlet plenum or discharge plenum, depending on the test configuration.

E2.2.3 *Duct Width (W_D).* The internal horizontal dimension of the duct.

E2.3 *Duct Total Pressure Loss (P_{TD}).* The total pressure loss in the duct. This loss is often negligible.

E2.4 *Plenum Length (L_P).* The distance from the internal wall of the plenum constructed by the Laboratory to either the nearest fan or Appurtenance.

Note: The manufacturer may designate this value as either fixed or a minimum.

E2.5 *Total Pressure Loss Entering Test Chamber (P_{TEC}).* The reduction in total air pressure caused by the expansion of the air flow as the air leaves the duct and enters the test chamber. This is used only when testing using the setup in the figure in AMCA 210 titled “Outlet Chamber Setup – Multiple Nozzles in Chamber” (Figure 6).

E2.6 *Total Pressure Loss Entering Unit (P_{TEU}).* The reduction in total air pressure caused by the contraction of the air when it leaves the duct and enters the unit. This is used only when testing using the setup in the figure in AMCA 210 titled “Inlet Chamber Setup – Multiple Nozzles in Chamber” (Figure 5). If the manufacturer provided the inlet plenum, this loss shall not be included.

E2.7 *Total Pressure Loss Leaving Test Chamber (P_{TLC}).* The reduction in total air pressure caused by the contraction of the air flow between the test chamber and the duct. This is used only when testing using the setup in the Figure in AMCA 210 titled “Inlet Chamber Setup – Multiple Nozzles in Chamber” (Figure 5).

E2.8 *Total Pressure Loss Leaving Unit (P_{TLU}).* The reduction in total air pressure caused by the contraction of the air when it leaves the unit and enters the duct. This is used only when testing using the setup in the figure in AMCA 210 titled “Outlet Chamber Setup – Multiple Nozzles in Chamber” (Figure 6). If the manufacturer provided the discharge plenum, this loss shall not be included.

E2.9 *Total Pressure Loss of Test Equipment.* The sum of the total pressure losses created by the portion of the test setup Constructed by the Laboratory.

E2.10 *Unit Dimensions.*

E2.10.1 *Unit Height (H_u)*. The internal vertical dimension of the unit under test.

E2.10.2 *Unit Width (W_u)*. The internal horizontal dimension of the unit under test.

E3 *Procedure.*

E3.1 Determine which components of pressure loss must be calculated.

E3.1.1 Testing using Figure 6 and manufacturer provides the discharge plenum (Figure E1): P_{TD} and P_{TLU} .

E3.1.2 Testing using Figure 6 and laboratory constructs the discharge plenum (Figure E2): P_{TEC} , P_{TD} and P_{TEC} .

E3.1.3 Testing using Figure 5 and manufacturer provides the inlet plenum (Figure E3): P_{TLC} and P_{TD} .

E3.1.4 Testing using Figure 5 and laboratory constructs the inlet plenum (Figure E4): P_{TLC} , P_{TD} and P_{TEU} .

E3.2 Calculate each of the pressure losses using the values for H_D , W_D , L_D , H_U , W_U , the air flow, and air density based on the procedures in ASHRAE Fundamentals Chapter 21 and the values in the ASHRAE Duct Fitting Database.

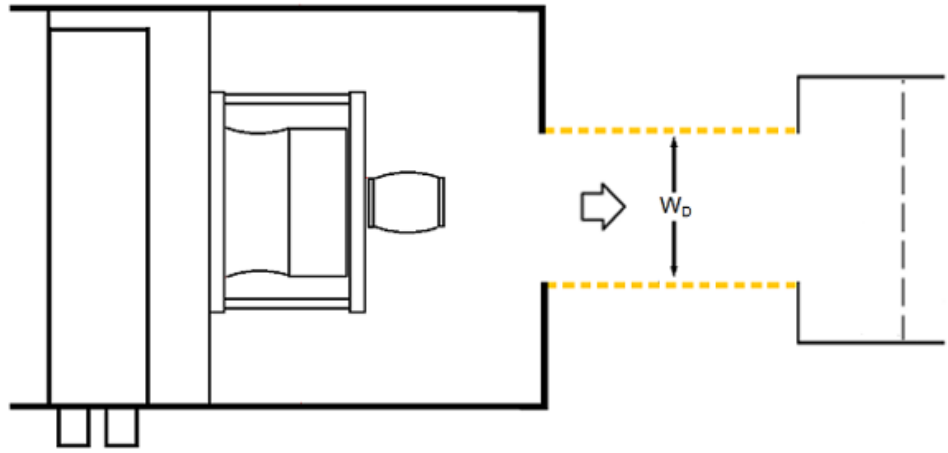

TOP VIEW

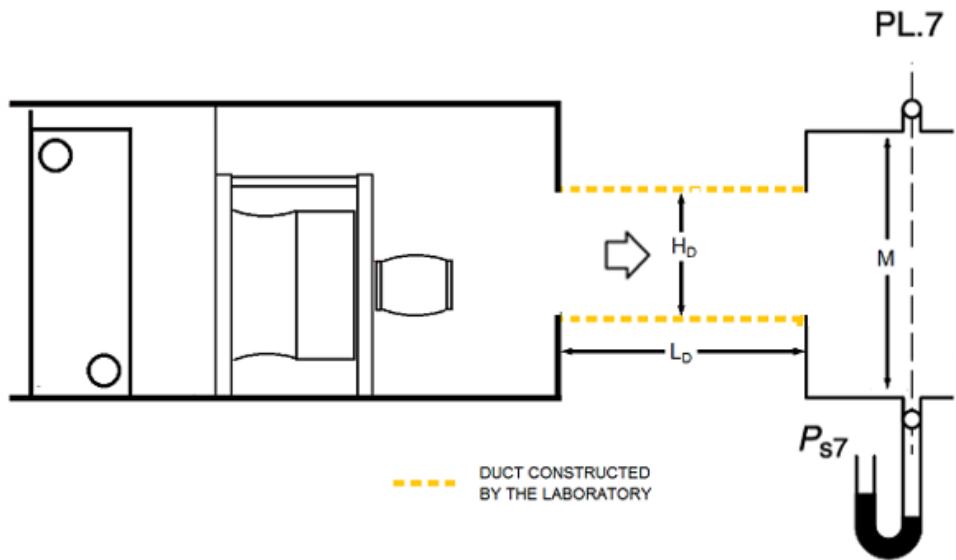

SIDE VIEW

Figure E1. Unit Tested with Discharge Plenum Supplied by the Manufacturer

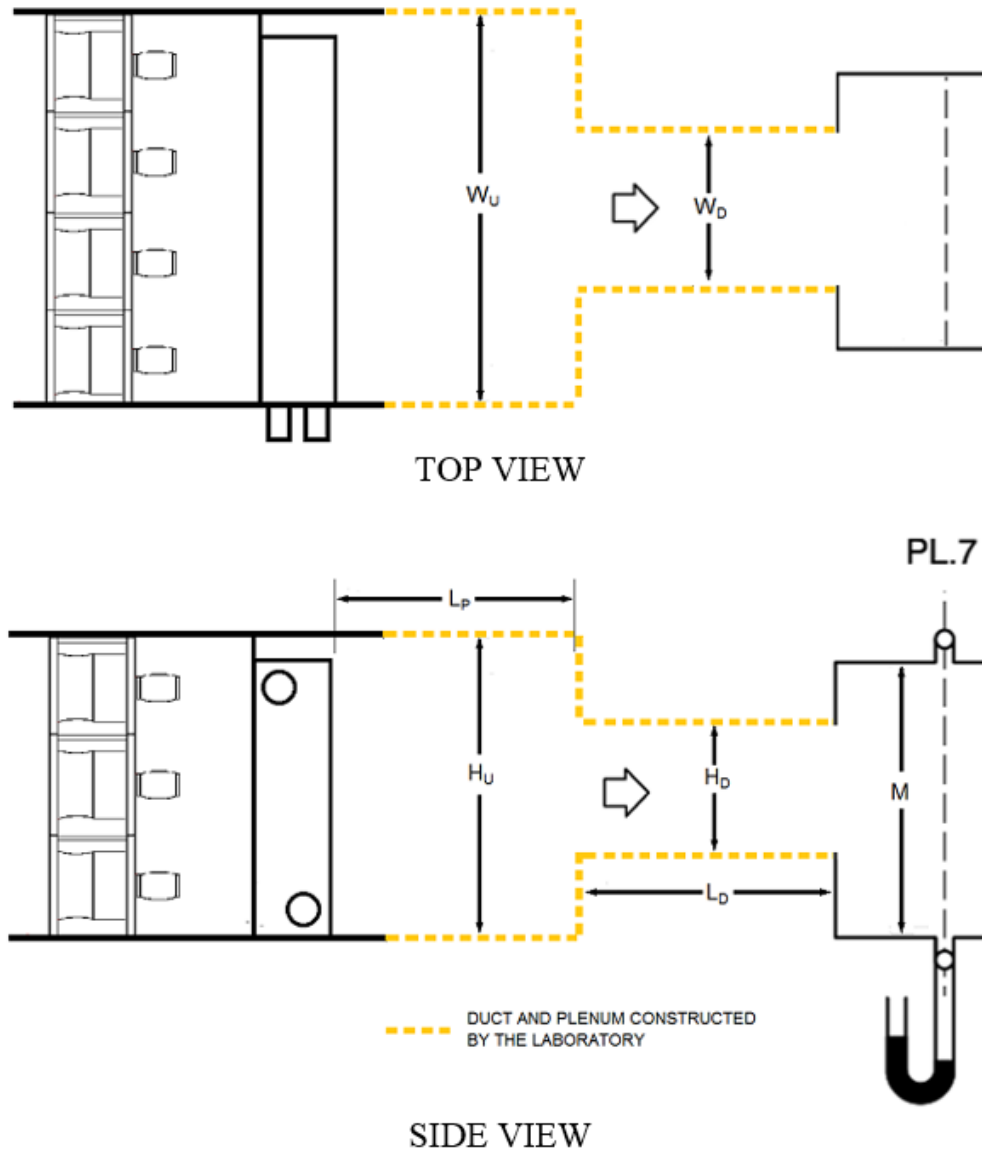

Figure E2. Unit Tested with Discharge Plenum Constructed by the Laboratory

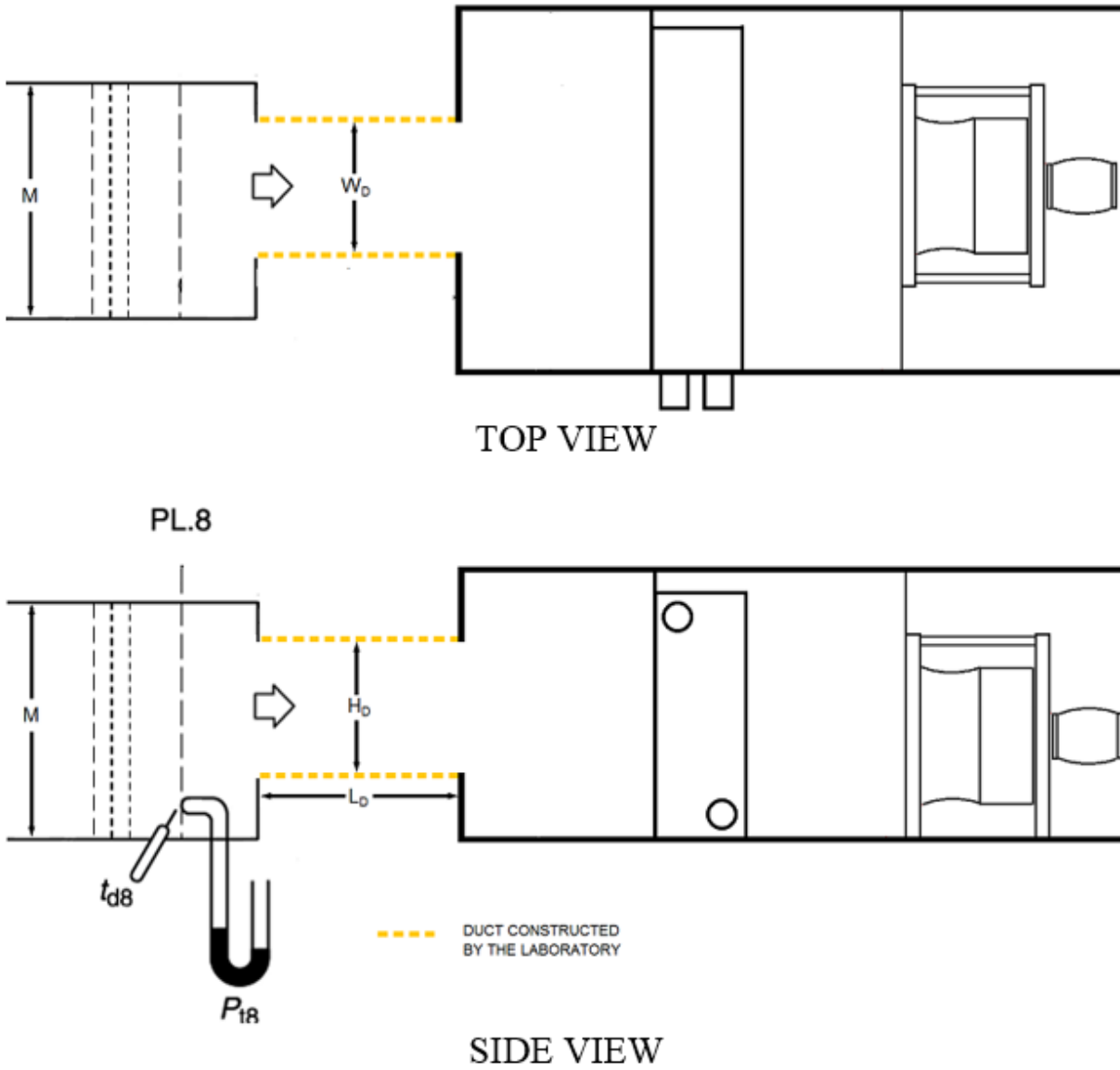

Figure E3. Unit Tested with Inlet Plenum Provided by the Manufacturer

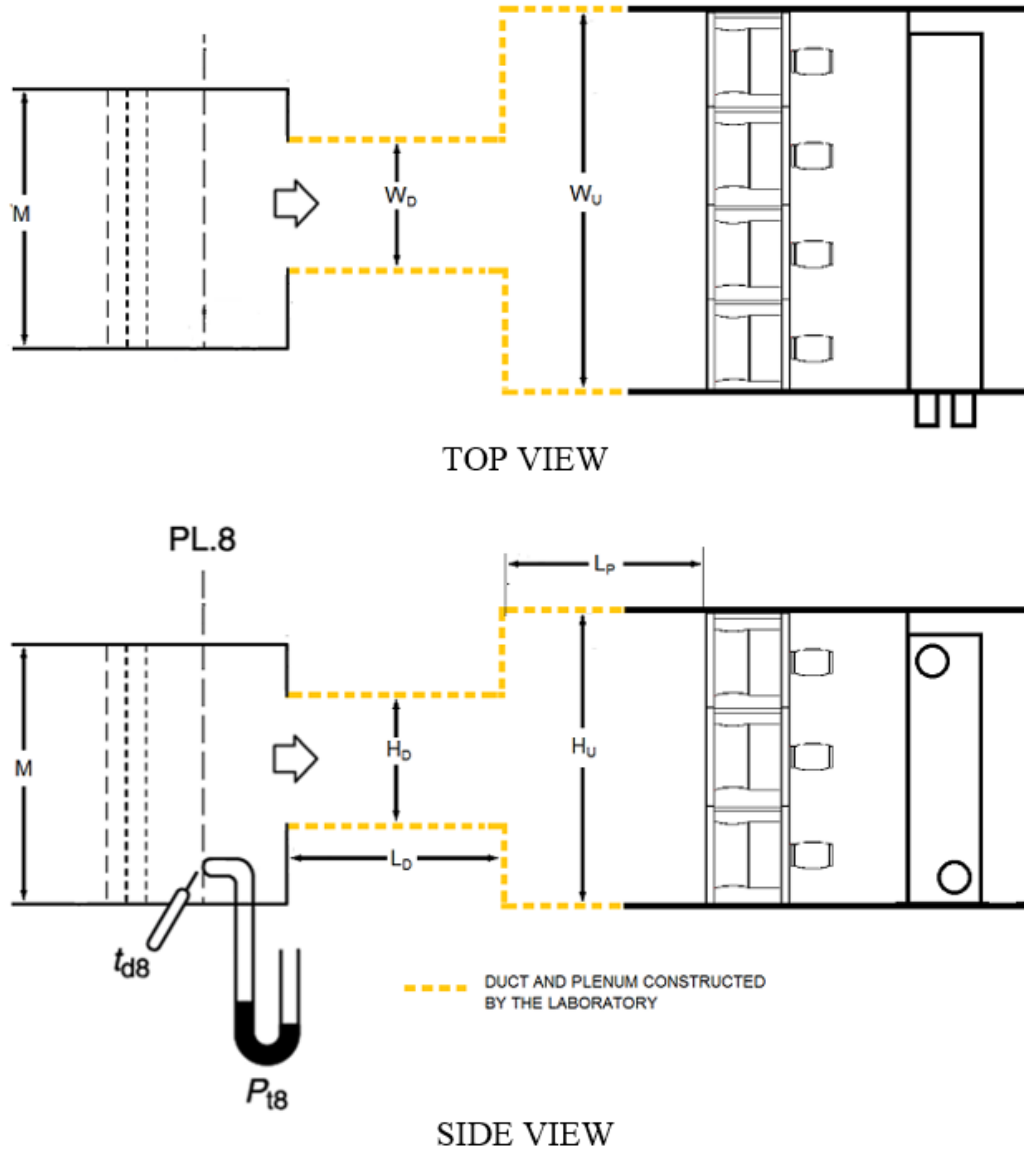

Figure E4. Unit Tested with Inlet Plenum Constructed by the Laboratory

APPENDIX F. UNITS WITH INLET GUIDE VANES – INFORMATIVE

F1 *Application of Fan Laws to Units with Inlet Vanes.* Units with inlet vanes may be rated one of three ways: 1) using the fan laws as described by Section 5.6.1 for proportional units with proportional fans and inlet vanes; 2) using the fan laws as described in Section 5.6.2 for proportional units with non-proportional fans and inlet vanes; or 3) using the fan laws by applying the appropriate inlet vane derate factors to units without inlet vanes rated per Sections 5.6.1 or 5.6.2 when the inlet vanes of the test unit are proportional to the inlet vanes of the rated units. (Since all requirements for proportionality of cabinets, fan impellers, and housing are satisfied by provisions in either Section 5.6.1 or 5.6.2 without inlet vanes, rated units with inlet vanes derived by inlet vane derate factors must only meet inlet vane proportionality criteria.)

Inlet vanes shall be considered proportional when the inlet vanes result in net airflow areas not less than 92.5% of those derived from exact proportionality (as defined in Section 5.6.1) when located within 0.5 impeller diameter from the fan inlet. The test unit shall be tested with vanes in the wide open position as specified by the manufacturer. Vane shaft angle, θ (with respect to fan shaft centerline), and the number of vane blades for the rated unit must be the same as for the test unit (Figure F1). When evaluating geometrical proportionality of inlet vanes, the distance between vane and impeller (defined as dimensions between impeller inlet plane and the closest point of vanes with the vanes at wide open position, as set by the manufacturer) and the distance between cabinet side and fan inlet shall be linearly proportional within 1.5%.

The method of rating one unit with inlet vanes from the test of another is described in Sections 5.6.2.1 through 5.6.2.7.

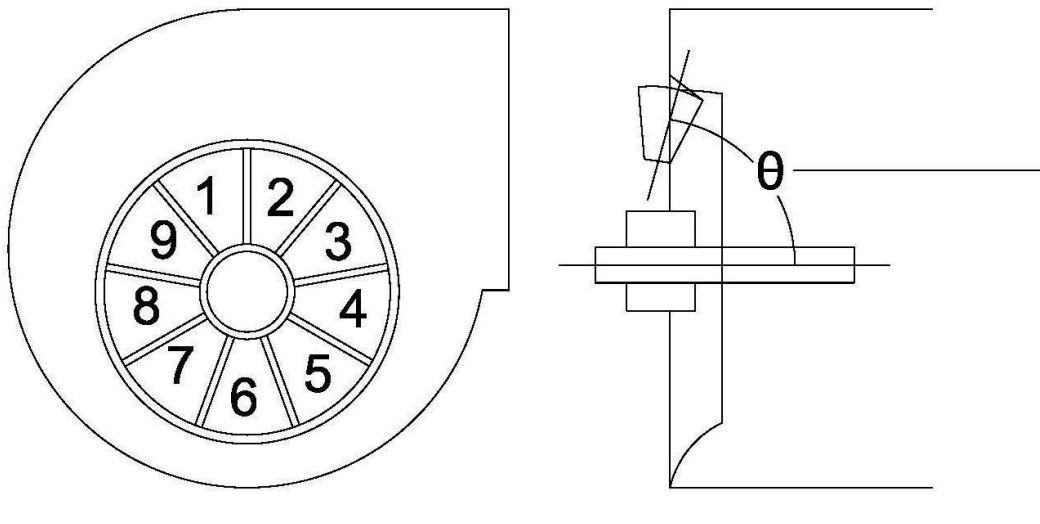

Figure F1. Dimensions for Inlet Vane Proportionality

θ = Angle from centerline of fan shaft to centerline of rotation of inlet vane, degrees

APPENDIX G. WIRE-TO-AIR MEASUREMENT – CALCULATION TO OTHER SPEEDS AND DENSITIES– NORMATIVE

G1 This appendix defines a method to interpolate between wire-to-air tests at multiple speeds to obtain fan ratings at an intermediate speed or different density. This standardized interpolation provides the fan pressure, airflow, and fan electrical input power at the same or new density given the electrical input power and associated performance of the fan at two rotational speeds – one speed greater and one speed less than the desired speed.

G2 *Requirements for the Use of this Appendix.*

G2.1 *Tested data.* Calculations shall be based on tested Supply Fan performance measured by a test performed per the requirements of Section 5.1.1.

G2.2 *Interpolating Between Tested Speeds.* This section describes the method of interpolation to develop ratings for a fan tested at two or more different speeds. The method only applies to adjacent tested fan speed curves. If three or more fan speeds were tested, a separate interpolation must be done between each fan speed curve. Calculations shall not be used to extrapolate to values greater than tested efficiencies.

G2.3 *Range of Application.* The interpolation method shall only be applied to speeds between two tested speeds; as described in Equation G1.

$$N_{\text{low}} < N < N_{\text{high}} \quad \text{G1}$$

G2.4 *Interpolation Along a System Curve.* All interpolated determination points must be on the same system curve, as described in equation G2.

$$\frac{P_{\text{low}}}{(\rho_{\text{std}} Q_{\text{low}})^2} = \frac{P}{(\rho Q)^2} = \frac{P_{\text{high}}}{(\rho_{\text{std}} Q_{\text{high}})^2} \quad \text{G2}$$

G3 *Interpolation of Airflow.* Airflow shall be calculated using this equation:

$$Q = Q_{\text{low}} + \left(\frac{N - N_{\text{low}}}{N_{\text{high}} - N_{\text{low}}} \right) \cdot (Q_{\text{high}} - Q_{\text{low}}) \quad \text{G3}$$

G4 *Interpolation of Total and Static Pressure.* Since all points are on the same system curve, total and/or static pressure shall be interpolated using this equation:

$$P = P_{\text{low}} \left(\frac{Q}{Q_{\text{low}}} \right)^2 \cdot \left(\frac{\rho}{\rho_{\text{std}}} \right) \quad \text{G4}$$

G5 *Interpolation of FEP.* Both airflow and static pressure must be greater than zero.

$$W = W_{\text{low}} + \left(\frac{QP - Q_{\text{low}}P_{\text{low}}}{Q_{\text{high}}P_{\text{high}} - Q_{\text{low}}P_{\text{low}}} \right) \cdot (W_{\text{high}} - W_{\text{low}}) \quad \text{G5}$$

G6 *Check on the wire-to-air efficiency at the new speed and density.* The equations in G5 may result in electrical input power outside the bounds of W_{low} and W_{high} . The resulting efficiency can be lower than the efficiency at both the lower and higher speed tests, however the resulting efficiency shall not exceed that of each of the tests. If this happens, the efficiency is capped at the higher of the two test results. Note that W in G6 is in units of Watts.

$$W \geq \frac{QP}{\eta_{max}}$$

G6

And:

η_{max} is the maximum of $\frac{Q_{low}P_{low}}{W_{low}}$ and $\frac{Q_{high}P_{high}}{W_{high}}$

APPENDIX H. FAN ELECTRICAL POWER WITH A SEPARATELY TESTED MOTOR OR COMBINED MOTOR CONTROLLER - NORMATIVE

H1 General

H1.1 This appendix is reproduced, with modification, from Annex H of AMCA 211. Copyright © 2013. Air Movement and Control Association International (AMCA). All rights reserved; reproduced by permission.

H1.2 This appendix covers rating of FEP based on testing fan shaft power H_{act} (shaft-to-air) separately from testing electric motor or PDS. The PDS could include an AC induction, electrically commutated, or permanent magnet motor and could include either a separate or integral VFD or other Motor Controller.

H1.3 In order to combine separate fan and drive component tests to determine FEP, the fan shaft power, H_i , is divided by the drive component efficiencies as shown in Figure H.1 corresponding to the required fan speed and shaft power. Note that these are not nameplate or nominal efficiencies; they are efficiencies corresponding to the required speed and load (in this document, the term “load” is used to refer to either shaft power or torque).

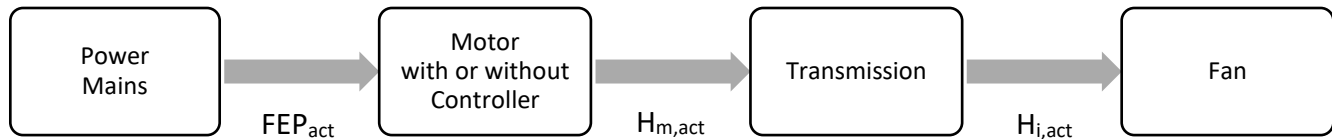

Figure H1. Fan Power and Drive Components

H1.4 V-belt or other transmission efficiency, if not tested with the fan, shall be calculated in accordance with AMCA 207 and used to determine motor output power:

$$H_{m,act} = H_{i,act} \cdot \left(\frac{1}{\eta_{transmission}} \right) \quad \text{H1}$$

H1.5 Fan electric power is then calculated using either direct lookup from a table containing tested electrical power or tested efficiency of the motor or PDS:

$$FEP_{act} = H_{m,act} \cdot \left(\frac{1}{\eta_{motor+control}} \right) \quad \text{H2}$$

H1.6 In some cases, PDS and transmission can be treated as a single unit, referenced in Fig H.1 as “Drive.” In such cases, they shall be tested as a single unit, and their respective efficiencies can be combined:

$$FEP_{act} = H_{i,act} \cdot \left(\frac{1}{\eta_{motor+control+transmission}} \right) \quad \text{H3}$$

H2 *Scope of Appendix H*

Table H1: Scope of Appendix H and its application	
Electric motors or PDS's in scope	Out of scope
<ul style="list-style-type: none"> • Wire-to-shaft efficiency of motor or -to-shaft PDS is determined based on testing with an absorption dynamometer according to standards in section H.3, and the bare-shaft fan is shaft-to-air rated based on tests according to AMCA 210 / ISO 5801 without a manufacturer-supplied motor. 	<ul style="list-style-type: none"> • Motors designed to be integrated into otherwise aerodynamically incomplete fan impellers • Fans that are wire-to-air tested according to AMCA 210 / ISO 5801

H3 *Testing of Electric Motor or PDS*

H3.1 Various motor and Motor Controller test standards exist, but none for the specific purpose of mapping PDS efficiency at all speeds and load points. Permissible test methods include portions of the following test standards, including their individual scope limits:

H3.1.1 ASHRAE 222

H3.1.2 CAN/CSA C838

H3.1.3 CSA C747

H3.1.4 IEEE 112

H3.2 The test standard selected shall be applicable to the equipment being tested, and shall be followed except that a) only the efficiency test need be run, and b) speed and load points used for drive component testing shall be as defined in section H.6.

H4 *Lab Requirements and Instrumentation*

H4.1 One of the test standards in section H.3 shall be used in an AMCA 111 or an ISO 17025 laboratory accreditation program to determine the motor or PDS efficiency.

H5 *Test Conditions*

H5.1 Motors and controllers shall be tested at the name plate voltage over the range of speeds and loads in which the fans are to be rated (see section H.6). Test conditions and equipment must be as specified in the test standard used. The temperature and operation of the motor(s) and controller(s) shall be stable for each tested operating point. If the PDS includes a separate Motor Controller, the input power is measured at the input to the controller.

H6 *Test Report*

H6.1 The test report shall include:

H6.1.1 Description of equipment tested, including manufacturer and model number

H6.1.2 Nameplate voltage, frequency, and power

H6.1.3 Controller parameters used for the test including mode (variable or constant torque), carrier frequency, maximum frequency, maximum output voltage, V/f ratio, and output algorithm

H6.1.4 Environmental conditions, such as barometric pressure, temperature and humidity during the test.

H6.1.5 Measurements and calculated data resulting in a map of the PDS input power (kW) vs. speed and load

H6.1.6 Additionally, the map may include PDS efficiency for each tested point.

H7 Speed and Load Points

H7.1 Speed and load determination points must cover the entire range to be rated. Determination points need not be restricted by motor nameplate ratings in speed or load; however, test data cannot be extrapolated beyond these measured points. Intermediate data between tested points shall be based on a simple linear interpolation or a polynomial curve fit. In no case shall the curve fit result in efficiencies exceeding the nearest test values. If efficiency vs. load is within 5% of average of all test speeds, the average efficiency vs. load can be used for this entire speed range.

For example, if the efficiency vs. load data includes the following values (91.5, 90, 88, 87, and 86), the average would be 88.5. A 5% range would include any values between 92.9 and 84.1, so this example would be allowed to use 88.5 for the entire range.

		Speed (% rated)				
		25%	50%	75%	100%	125%
Torque (% rated)	125%				X	
	100%			X	X	X
	75%		X	X	X	X
	50%	X	X	X	X	X
	25%	X	X	X	X	X

(Efficiency Values)		Speed (% rated)				
		25%	50%	75%	100%	125%
Torque (% rated)	125%				88%	
	100%			91%	90%	88%
	75%		86%	89%	88%	86%
	50%	79%	83%	85%	85%	83%
	25%	70%	79%	81%	81%	79%

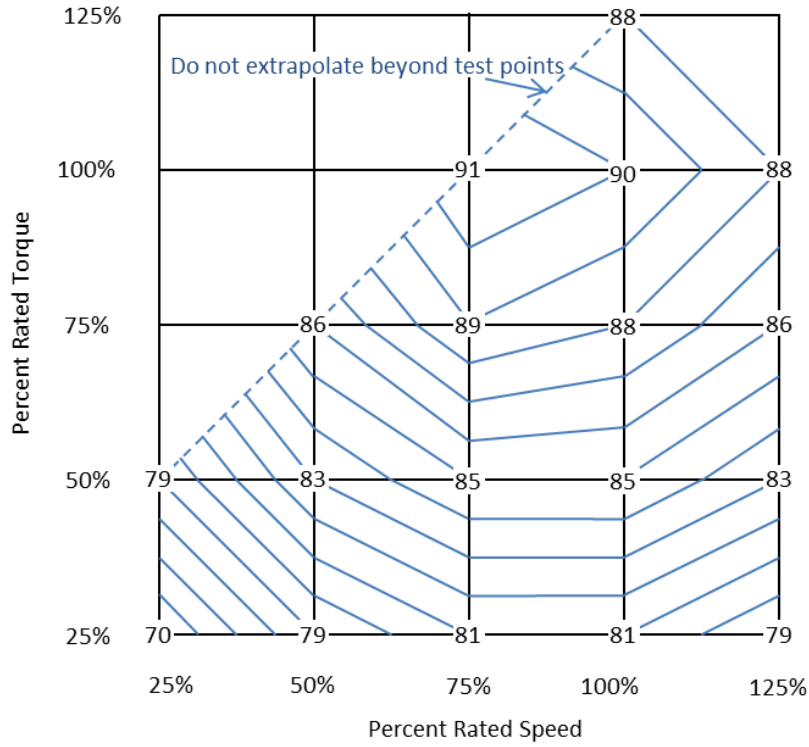

Figure H2: Example of Interpolation (Efficiency vs. Torque and Speed)

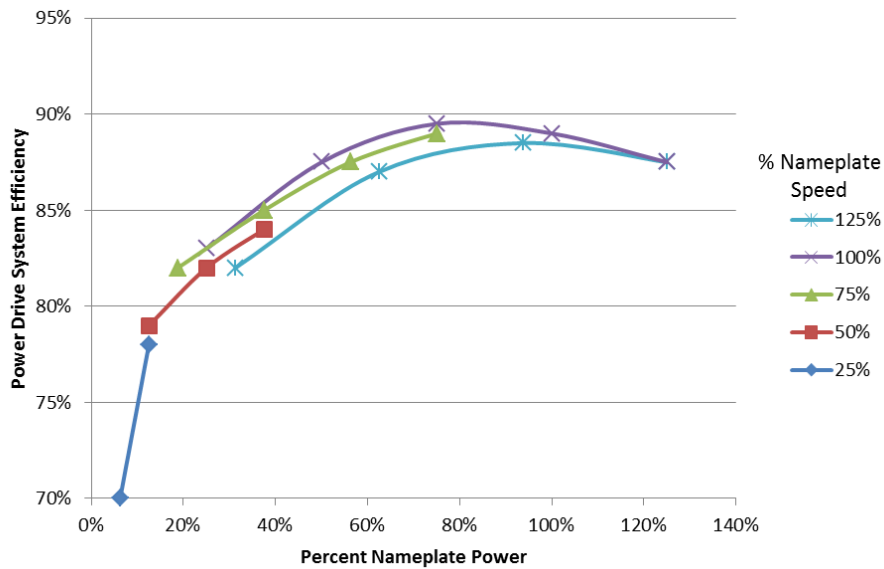

Figure H3: Example of Curve Fit (Efficiency vs. Power and Speed)