

**ANSI/AHRI Standard 900 (I-P)**

**2014 (R2020) Standard for  
Performance Rating  
of Thermal Storage  
Equipment Used  
for Cooling**



Approved by ANSI on September 24, 2020



we make life better®

2311 Wilson Boulevard, Suite 400  
Arlington, VA 22201, USA  
[www.ahrinet.org](http://www.ahrinet.org)  
PH 703.524.8800  
FX 703.562.1942

**IMPORTANT**

***SAFETY DISCLAIMER***

AHRI does not set safety standards and does not certify or guarantee the safety of any products, components or systems designed, tested, rated, installed or operated in accordance with this standard/guideline. It is strongly recommended that products be designed, constructed, assembled, installed and operated in accordance with nationally recognized safety standards and code requirements appropriate for products covered by this standard/guideline.

AHRI uses its best efforts to develop standards/guidelines employing state-of-the-art and accepted industry practices. AHRI does not certify or guarantee that any tests conducted under its standards/guidelines will be non-hazardous or free from risk.

Note:

This standard supersedes AHRI 900-2010.  
For SI ratings, see ANSI/AHRI Standard 901 (SI)–2014 (R2020).

## TABLE OF CONTENTS

SECTION	PAGE
Section 1. Purpose.....	1
Section 2. Scope.....	1
Section 3. Definitions.....	1
Section 4. Classifications.....	3
Section 5. Test Requirements .....	4
Section 6. Rating Requirements.....	5
Section 7. Minimum Data Requirements for Published Ratings .....	7
Section 8. Marking and Nameplate Data .....	7
Section 9. Conformance Conditions .....	8

## TABLES

Table 1. Classification of Thermal Storage Equipment.....	4
Table 2. Limits of Mapped Rating Conditions and Method of Testing .....	6
Table 3A. Supplier Specified Data – Example Design Day .....	9
Table 3B. Supplier Specified Discharge Data for Unitary Thermal Storage Systems .....	11
Table 4. Charge Cycle Rating Conditions for Unitary Thermal Storage Systems .....	11

## APPENDICES

Appendix A. References – Normative.....	12
Appendix B. References – Informative .....	13
Appendix C. Method of Testing for Rating Thermal Storage Devices Which Employ the Same Secondary Coolant for the Charge and Discharge Cycles – Normative .....	14
Appendix D. Method of Testing for Rating Unitary Thermal Storage Systems – Normative .....	27

## APPENDICES – (continued)

Appendix E.	Method of Field Testing for Rating Thermal Storage Devices – Normative .....	39
Appendix F.	Method of Testing for Rating Thermal Storage Devices Which Employ Different Heat Transfer Fluids for the Charge Cycle and the Discharge Cycle – Normative.....	51

### TABLES FOR APPENDICES

Table C1.	Temperature Comparison – Charge and Discharge Cycles .....	26
Table D1.	Power Comparison – Charge Cycle Test .....	38
Table D2.	Temperature Comparison – Discharge Cycle Test .....	38
Table E1.	Temperature Comparison – Charge and Discharge Cycles .....	50
Table F1.	Temperature Comparison – Charge and Discharge Cycles .....	68

### FIGURES FOR APPENDICES

Figure C1.	Thermal Storage Device Test Apparatus .....	16
Figure D1.	Discharge Cycle Test Apparatus.....	28
Figure E1.	Thermal Storage Device Test Apparatus .....	40
Figure F1.	Discharge Cycle Test Apparatus.....	52
Figure F2.	Refrigeration System with Secondary Coolant.....	54
Figure F3.	Refrigeration System with Direct Expansion Feed.....	54
Figure F4.	Refrigeration System with Gravity Feed .....	55
Figure F5.	Refrigeration System with Pumped Overfeed .....	55
Figure F6.	Typical Calorimeter Instrument.....	57

# PERFORMANCE RATING OF THERMAL STORAGE EQUIPMENT USED FOR COOLING

## Section 1. Purpose

**1.1** *Purpose.* The purpose of this standard is to establish for Thermal Storage Equipment used for cooling: definitions; classifications; test requirements; rating requirements; minimum data requirements for Published Ratings; operating requirements; marking and nameplate data; and conformance conditions.

**1.1.1** *Intent.* This standard is intended for the guidance of the industry, including manufacturers, engineers, installers, contractors, and users.

**1.1.2** *Review and Amendment.* This standard is subject to review and amendment as the technology advances.

## Section 2. Scope

**2.1** *Scope.* This standard applies to Thermal Storage Equipment used for cooling which may be charged and discharged with any of a variety of heat transfer fluids. The equipment, as further described in Sections 3 and 4, may be fully factory assembled; assembled on site from factory supplied components; or field erected in accordance with pre-established design criteria.

**2.2** *Exclusions.* This standard does not apply to:

**2.2.1** Thermal Storage Equipment with storage capacities of 7 ton-hours or less

**2.2.2** Thermal Storage Equipment used solely for heating

## Section 3. Definitions

All terms in this document shall follow the standard industry definitions in the current edition of *ASHRAE Terminology* website (<https://www.ashrae.org/resources--publications/free-resources/ashrae-terminology>) unless otherwise defined in this section. For the convenience of users of this standard, definitions for the more important terms employed in this standard are provided below:

**3.1** *Ambient Air.* The air in the space surrounding the thermal energy storage device.

**3.2** *Ambient Heat Load.* The load (typically expressed in tons) imposed on the storage device due to heat gain from the ambient.

**3.3** *Charge Fluid.* The heat transfer fluid used to remove heat from a Thermal Storage Device.

**3.4** *Charge Period/Cycle.* The Period of time when energy (heat) is removed from the storage device.

**3.5** *Charge Rate.* The rate (typically expressed in tons) at which energy (heat) is removed from the storage device during the Charge Period.

**3.6** *Discharge Fluid.* The heat transfer fluid used to add heat to the Thermal Storage Device.

**3.7** *Discharge Period/Cycle.* The Period of time when energy (heat) is added to the storage device.

**3.8** *Discharge Rate.* The rate (typically expressed in tons) at which energy (heat) is added to the storage device during the Discharge Period.

- 3.9** *Fouling Factor Allowance.* A thermal resistance included in heat transfer calculations to account for the fouling expected over time on the air, refrigerant, or water side area of a heat transfer surface.
- 3.10** *Hermetic Compressor.* A motor-compressor assembly contained within a gas-tight casing which uses the refrigerant as the motor coolant. This includes semi-hermetic compressors.
- 3.11** *Interval.* The time span between individual test readings.
- 3.12** *Load Intensity.* The ratio of the instantaneous load imposed upon the storage device to the Net Usable Storage Capacity of the unit, typically expressed in tons/ton-hours.
- 3.13** *Net Storage Inventory.* Net accumulated measured Storage Capacity at a given period of time during a 24 hour cycle.
- 3.14** *Open-type Compressor.* A refrigerant compressor with a shaft or other moving part extending through the casing to be driven by an outside source of power.
- 3.15** *Period.* The one hour time segments into which the total duty cycle of a thermal storage system is divided for the purpose of analysis and evaluation.
- 3.16** *Phase Change Material (PCM).* A substance that undergoes changes of state while absorbing or rejecting thermal energy, normally at a constant temperature.
- 3.17** *Published Ratings.* Published Ratings for Thermal Storage Equipment are the data and methodology by which the "Supplier Specified Data", as set forth in Table 3 of this standard, are developed for a specified duty cycle. They may take the form of tables, graphs, or computer programs, as elected by the manufacturer, and shall apply to all units of like nominal size and type (identification) produced by the same manufacturer.
- 3.17.1** *Standard Rating.* A rating based on tests performed at standard rating conditions.
- 3.17.2** *Mapped Rating(s).* Mapped Ratings are ratings falling within certain specified limits that are provided for products which do not have a standard rating condition. They are based upon tests performed across a range of operating conditions as defined by the product manufacturer.
- 3.17.3** *Application Rating.* A rating, based on tests performed at application rating conditions (other than standard or mapped rating conditions).
- 3.18** *Saturated Evaporator Temperature (SET).* The dew point temperature of the refrigerant corresponding to the saturation pressure at the outlet connection of the evaporator.
- 3.19** *Saturated Return Temperature.* The temperature of the refrigerant corresponding to the saturation pressure at the return connection of a Unitary Thermal Storage System.
- 3.20** *Secondary Coolant.* Any liquid cooled by a refrigerant and used for heat transmission without a change in state, having no flash point or a flash point above 150°F.
- 3.21** *"Shall" or "Should."* "Shall" or "Should" shall be interpreted as follows:
- 3.21.1** *Shall.* Where "shall " or "shall not" is used for a provision specified, that provision is mandatory if compliance with the standard is claimed.
- 3.21.2** *Should.* "Should" is used to indicate provisions which are not mandatory, but which are desirable as good practice.
- 3.22** *Storage Capacity.* Storage Capacity, as used in this standard, shall be defined as follows:
- 3.22.1** *Measured Storage Capacity.* The Storage Capacity of a Unitary Thermal Storage System (UTSS) determined during a given Storage Cycle in the charge cycle test, typically expressed in ton-hours.

**3.22.2** *Net Usable Storage Capacity.* The amount of stored cooling that can be supplied from the storage device at or below the specified cooling supply temperature for a given Charge and Discharge Cycle, typically expressed in ton-hours.

**3.22.3** *Nominal Storage Capacity.* A theoretical capacity of the storage device as defined by the storage device manufacturer (which in many cases is greater than the Net Usable Storage Capacity), typically expressed in ton-hours.

**3.23** *Thermal Storage Device.* Equipment which stores cooling capacity using sensible and/or latent heat. This equipment may consist solely of a storage means or be packaged with one or more components of a mechanical refrigeration system.

**3.24** *Thermal Storage Equipment.* Any one of, or a combination of, Thermal Storage Devices and/or Unitary Thermal Storage Systems, that may include various other components of a mechanical refrigeration package (Section 4).

**3.25** *Ton-hour (ton-h).* The quantity of thermal energy equal to 12,000 Btu or 1 ton of refrigeration provided for one hour.

**3.26** *Unitary Thermal Storage System (UTSS).* An assembly of components including a Thermal Storage Device and refrigeration equipment for charging, whose overall performance as a Unitary Thermal Storage System is rated by the manufacturer.

## **Section 4. Classifications**

**4.1** *Classification.* Thermal Storage Equipment is broadly classified as either "sensible" or "latent", with further delineations as shown in Table 1 and explained in subsequent paragraphs.

**4.1.1** *Sensible Thermal Storage Equipment.* Sensible Thermal Storage Equipment used for cooling typically employs water as the storage medium. During the Charge Period, warm water from the storage device is chilled to the desired temperature by a water chiller and returned to the storage vessel. During the Discharge (cooling) Period, the chilled water is pumped from the storage vessel to the load and the resultant warm water returned to storage. Any of several methods may be used to keep the warm return water separated from the stored chilled water, including separate or compartmentalized tanks or where only one tank is employed, labyrinths, membranes, or thermal stratification.

**4.1.2** *Latent Thermal Storage Equipment.* Latent Thermal Storage Equipment is further categorized as ice-on-coil, encapsulated ice or Phase Change Material, ice harvester/chiller, ice slurry, or unitary.

**4.1.2.1** *Ice-on-Coil.* A Thermal Storage Device consisting of coils, plates, or other heat transfer surface submerged in a water filled tank. During the Charge Period, an evaporating refrigerant or cold Secondary Coolant is circulated through the coils/plates causing ice to form on the external surfaces. During the Discharge (cooling) Period, either of two methods is typically employed:

**4.1.2.1.1** *External Melt.* With external melt, warm, return water is circulated through the tank, external to the ice formation, whereby it is cooled by the melting ice.

Some ice-on-coil devices may also serve as water chillers by circulating warm return water through the tank and over the external surface of the heat exchanger where it is cooled by Secondary Coolant or refrigerant circulating within the exchanger.

**4.1.2.1.2** *Internal Melt.* With internal melt, typically a warm, return, Secondary Coolant is circulated through the coils/plates and cooled as the ice external to the coils/plates is melted.

**4.1.2.2** *Encapsulated Ice or Phase Change Material.* Thermal Storage Equipment consisting of a tank or vessel densely packed with numerous, relatively small containers in which the storage medium (water-ice or other Phase Change Material such as eutectic salt) is encapsulated. During the Charge Period, water or Secondary Coolant, at a temperature below the phase change temperature of the storage media, is circulated through the tank/vessel to effect a phase change (freezing) in the storage medium. During the Discharge Period, warm return water or Secondary Coolant is circulated through the tank/vessel and cooled as the encapsulated storage media changes phase (melts).

**4.1.2.3 Unitary.** An assembly of components including a Thermal Storage Device and refrigeration equipment for charging which is rated by the manufacturer as a UTSS. The Thermal Storage Device consists of a heat exchanger submerged in a water filled tank. During the Charge Period, an evaporating refrigerant or cold Secondary Coolant is circulated through the heat exchanger causing ice to form on the external surface. During the Discharge (cooling) Period, a condensing refrigerant or warm Secondary Coolant is cooled by internal and/or external melt processes.

Table 1. Classification of Thermal Storage Equipment				
Classification	Type	Storage Media	Charge Fluid	Discharge Fluid
Sensible	Chilled Water	Water or other Aqueous Solution	Water or other Aqueous Solution	Water or other Aqueous Solution
Latent	Ice-on-Coil (External Melt)	Ice or other Phase Change Material	Secondary Coolant	Water or Secondary Coolant
			Refrigerant	
	Ice-on-Coil (Internal Melt)	Ice or other Phase Change Material	Secondary Coolant	Secondary Coolant
	Encapsulated Ice or Phase Change Material	Ice or other Phase Change Material	Water	Water
Secondary Coolant			Secondary Coolant	
Unitary	Ice or other Phase Change Material	Ice or other Phase Change Material	Refrigerant or Secondary Coolant	Refrigerant, Water or Secondary Coolant

**Section 5. Test Requirements**

**5.1 Test Requirements.** All Standard and Mapped Ratings shall be verified by tests conducted in accordance with the methods, procedures, and instrumentation set forth in Appendices C, D, E or F of this standard, as applicable.

**5.2 Tolerances for Thermal Storage Devices.** Published Mapped Ratings shall be such that any production Thermal Storage Device, upon test, shall have a Net Usable Storage Capacity of not less than 100% of its rated Net Usable Storage Capacity, with:

**5.2.1** Fluid side pressure drop values no greater than 15% above the rated values.

**5.2.2** Average fluid temperatures (or saturated suction temperatures) for each Period during the Charge Cycle no lower than 0.5°F below the values predicted by the Published Rating methodology for the specified charge duration.

**5.2.3** Average fluid temperatures for each Period during the Discharge Cycle no higher than 0.5°F above those predicted by the Published Rating methodology for the specified load profile.

**5.2.4** Where applicable, a full load power input at any point during the cycle not more than 5% greater than its power input rating.



**5.3** *Tolerances for Unitary Thermal Storage Systems.* Published Mapped Ratings shall be such that any production UTSS, upon test, shall have an average charging power input no greater than 5% above the rated value for each outdoor ambient rating condition and a Net Usable Storage Capacity of not less than 100% of its rated value with average fluid temperatures for each Period during the Discharge Cycle no higher than 0.5°F above those predicted by the published rating methodology for the specified load profile.

## **Section 6. Rating Requirements**

**6.1** *Rating Conditions.* The type of equipment shall determine the form of the Published Ratings, as specified below:

**6.1.1** *Thermal Storage Devices.* Published Ratings of Thermal Storage Devices shall include Mapped Ratings (Table 2) and Application Ratings consisting of the Net Usable Storage Capacity of the device and the auxiliary power input rating accompanied by the performance data as specified in Table 3 of this standard.

**6.1.1.1** *Mapped Ratings.* The Mapped Ratings for each type of Thermal Storage Device shall be limited to the range of conditions set forth in Table 2.

Table 2. Limits of Mapped Rating Conditions and Method of Testing						
Equipment Type	Method of Testing	Discharge Cycle				Charge Cycle
		Load Intensity, tons/ton-hours	Period, h	Entering Fluid Temperature, °F	Leaving Fluid Temperature, °F	Period, h
Chilled Water	Appendix E	0.08 to 0.25	4 to 12	45 to 65	40 to 60	8 to 12
Ice-on-Coil External Melt	Appendix F	0.08 to 0.25	4 to 12	40 to 60	34 to 50	8 to 12
Ice-on-Coil Internal Melt	Appendix C	0.08 to 0.25	4 to 12	40 to 60	38 to 50	8 to 12
Encapsulated Ice	Appendix C or E	0.08 to 0.25	4 to 12	40 to 60	38 to 50	6 to 12
Phase Change Material (PCM)	Appendix C or E	0.08 to 0.25	4 to 12	8 to 28 above Phase Change Temperature	6 to 18 above Phase Change Temperature	8 to 12
Unitary	Appendix D	0.08 to 0.25	4 to 12	38 to 60	38 to 50	6 to 14

**6.1.1.2 Auxiliary Power Input Rating.** Published auxiliary power input ratings for Thermal Storage Devices shall be the power required from the customer’s power source by all auxiliary components of the Thermal Storage Device that shall operate during the Charge Cycle and/or Discharge Cycle to produce the Net Usable Storage Capacity, including any motors, motor starters, frequency converters, and controls furnished by the manufacturer. Power required by pumps circulating Secondary Coolants to the thermal storage system load external to the Thermal Storage Device shall be excluded.

**6.1.2 Unitary Thermal Storage Systems.** Published Ratings of UTSS shall include the Mapped Ratings of the Net Usable Storage Capacity accompanied by the performance data as specified in Table 3b and the average charge rate and power input ratings when operating at the charge cycle rating conditions specified in Table 4 of this standard.

**6.1.2.1 Mapped Ratings.** The Mapped Ratings for UTSS shall be limited to the range of conditions set forth in Table 2.

**6.1.2.2 Power Input Rating.** Published power input ratings for a UTSS shall be the power required from the customer’s power source by all components of the UTSS that shall operate during the Charge Cycle and/or Discharge Cycle to produce the Net Usable Storage Capacity, including, but not limited to the compressor motor(s), condenser fan motor(s), pump(s), motor starters, frequency converters and controls furnished by the manufacturer. Power required by pumps circulating Secondary Coolants or water to the thermal storage system load external to the UTSS shall be excluded.

**6.1.2.3 Fouling Factor Allowance.** Calculation of results shall not include Fouling Factor Allowances to determine Published Ratings of a UTSS.

**6.2** *Application Ratings.* Application Ratings are ratings at conditions falling outside the boundaries of mapped rating conditions or at other than standard rating conditions, as may be elected by the manufacturer to facilitate the selection of equipment.

**6.3** *Specific Conditions.* Ratings prepared by the manufacturer to address a specific job requirement should include the performance data set forth in Table 3 of this standard, over the full Charge and Discharge Cycle.

## **Section 7. Minimum Data Requirements for Published Ratings**

**7.1** *Published Ratings.* As a minimum, Published Ratings shall include, or be capable of generating, unit designation(s), Mapped or Standard Ratings for each such unit, and any additional Application Ratings as the manufacturer may elect to include. Ratings shall be accompanied by the following information:

### **7.1.1** *Thermal Storage Devices.*

- 7.1.1.1** Net Usable Storage Capacity, ton-hour
- 7.1.1.2** Auxiliary power input rating, kW
- 7.1.1.3** Type of heat transfer fluid used during the Charge and Discharge Cycles
- 7.1.1.4** Performance data specified in Table 3a
- 7.1.1.5** Initial Charge Period, h,
- 7.1.1.6** Minimum entering temperature of the heat transfer fluid over the duration of the Charge Cycle, °F
- 7.1.1.7** Pressure drop of heat transfer fluid across the Thermal Storage Device, psi, at the maximum flow rate encountered during the Charge and Discharge Cycles, gpm
- 7.1.1.8** Design working pressure(s), psi

### **7.1.2** *Unitary Thermal Storage Systems.*

- 7.1.2.1** Power input requirements during the Charge and Discharge Periods, kW
- 7.1.2.2** Nominal voltages, V
- 7.1.2.3** Frequencies for which the rating is valid, Hz
- 7.1.2.4** Net Usable Storage Capacity, ton-hour
- 7.1.2.5** Average Charge Rate during each Charge Period of the charge cycle test, tons
- 7.1.2.6** Designation of the refrigerant used during the charge cycle, in accordance with ANSI/ASHRAE Standard 34 with Addenda
- 7.1.2.7** Type of refrigerant or heat transfer fluid used during the Discharge Cycle
- 7.1.2.8** Performance data specified in Tables 3b & 4

## **Section 8. Marking and Nameplate Data**

**8.1** *Marking and Nameplate Data.* As a minimum, the unit nameplate shall display:

- 8.1.1** The name of the manufacturer and/or the supplier responsible for the performance ratings
- 8.1.2** The model number of the equipment and a serial number uniquely identifying the product
- 8.1.3** Where applicable, the refrigerant designation used during the charge cycle, in accordance with ANSI/ASHRAE Standard 34 with Addenda
- 8.1.4** Where applicable, the electrical characteristics and power consumption of auxiliaries, motors, and controls included in the device or package

Nameplate voltages for 60 Hertz systems shall include one or more of the equipment nameplate voltage ratings shown in ANSI/AHRI Standard 110, Table 1. Recommended nameplate voltages for 50 Hertz systems shall include one or more of the utilization voltages shown in IEC Standard 60038, Table 1.

## Section 9. Conformance Conditions

**9.1** *Conformance.* While conformance with this standard is voluntary, conformance shall not be claimed or implied for products or equipment within the standard's *Purpose* (Section 1) and *Scope* (Section 2) unless such product claims meet all of the requirements of the standard and all of the testing and rating requirements are measured and reported in complete compliance with the standard. Any product that has not met all the requirements of the standard cannot reference, state, or acknowledge the standard in any written, oral, or electronic communication.

**Table 3A. Supplier Specified Data – Example Design Day**

Hour	Thermal Storage System Load, tons	Refrigeration Equipment Load, tons	Storage Device Charge or Discharge Rate <sup>1</sup> , tons	Parasitic and Accessory Heat Load into Storage, tons	Ambient Heat Load into Storage Device, tons	Net Storage Inventory <sup>2</sup> , ton-hour	Saturated Evaporator Temperature <sup>3</sup> (If Applicable), °F
0-1							
1-2							
2-3							
3-4							
4-5							
5-6							
6-7							
7-8							
8-9							
9-10							
10-11							
11-12							
12-13							
13-14							
14-15							
15-16							
16-17							
17-18							
18-19							
19-20							
20-21							
21-22							
22-23							
23-0							
TOTALS			N/A			N/A	N/A
Net Usable Storage Capacity		Heat Transfer Fluid	Specific Gravity		Specific Heat		Other Refrigeration Energy Inputs are Required?
_____ ton-hour		_____	_____ @ _____ °F		_____ Btu/lb/°F @ _____ F		<input type="checkbox"/> YES <input type="checkbox"/> NO
Notes: 1. Greater Discharge Rates may not be possible at the defined discharge temperature 2. Net Storage Inventory Values are not available for instantaneous discharge 3. Applicable where refrigerant is the Charge Fluid.							

**Table 3A. Supplier Specified Data – Example Design Day (continued)**

Hour	Load Supply Temperature - T1, °F	Load Return Temperature - T2, °F	Flow Rate to Load, gpm	Fluid Temperature Entering Storage Device - T3, °F	Fluid Temperature Leaving Storage Device - T4, °F	Flow Rate through Storage Device, gpm	Pressure Drop Across Storage Device, psi	Storage Device Refrigeration Energy Input, kWh	Condenser Load, kBtu/h or Water Flow, gpm	Refrigeration Condensing or Heat Sink Temp. <sup>4</sup> , °F	Power Input to Storage Device, kW
0-1											
1-2											
2-3											
3-4											
4-5											
5-6											
6-7											
7-8											
8-9											
9-10											
10-11											
11-12											
12-13											
13-14											
14-15											
15-16											
16-17											
17-18											
18-19											
19-20											
20-21											
21-22											
22-23											
23-0											
TOTAL	N/A	N/A	N/A	N/A	N/A	N/A	N/A			N/A	
Notes: 4. Specify the type of Heat Sink and the Temperature (Entering Condenser Water Temperature, Entering Air Dry-bulb Temperature, Entering Air Wet-bulb Temperature).											

Table 3b. Supplier Specified Discharge Data for Unitary Thermal Storage Systems								
Discharge Hour	Thermal Storage System Load, tons	Refrigeration Equipment Load, tons	Storage Device Discharge Rate <sup>1</sup> tons	Parasitic and Accessory Heat Load into Storage, tons	Ambient Heat Load into Storage Device, tons	Net Storage Inventory <sup>2</sup> , ton-hour	Saturated Return Temperature <sup>3</sup> , °F	Power Input to UTSS, kW
0-1								
1-2								
2-3								
3-4								
4-5								
5-6								
6-7								
7-8								
8-9								
9-10								
10-11								
11-12								
TOTALS			N/A			N/A	N/A	

Notes:

- Greater Discharge Rates may not be possible at the defined discharge temperature
- Net Storage Inventory Values are not available for instantaneous discharge
- For a UTSS using a Secondary Coolant as the Discharge Fluid, use the leaving fluid temperature in place of the Saturated Return Temperature

Table 4. Charge Cycle Rating Conditions for Unitary Thermal Storage Systems			
Ambient, °F	Charge Rate, tons	Charge Duration, h	Power Input, kW
55			
65			
75			
85			
95			





## APPENDIX A. REFERENCES – NORMATIVE

**A1** Listed here are all standards, handbooks and other publications essential to the formation and implementation of the standards. All references in this appendix are considered as part of the standard.

**A1.1** ANSI/AHRI Standard 110-2012, *Air-Conditioning and Refrigerating Equipment Nameplate Voltages*, 2012, Air-Conditioning, Heating and Refrigerating Institute, 2111 Wilson Boulevard, Suite 500, Arlington, VA 22201, U.S.A.

**A1.2** ANSI/AHRI Standard 901 (SI)-2014 (reaffirmed by AHRI 2020), *Performance Rating of Thermal Storage Equipment Used for Cooling*, 2014, Air-Conditioning, Heating and Refrigerating Institute, 2311 Wilson Boulevard, Suite 400, Arlington, VA 22201, U.S.A.

**A1.3** ANSI/ASHRAE Standard 34 – 2013 with Addenda, *Designation and Safety Classification of Refrigerants*, 2013, American Society of Heating, Refrigerating and Air-Conditioning Engineers, 1791 Tullie Circle N.E., Atlanta, GA 30329, U.S.A.

**A1.4** ANSI/ASHRAE Standard 37 - 2009, *Methods of Testing for Rating Electrically Driven Unitary Air-Conditioning and Heat Pump Equipment*, 2009, American Society of Heating, Refrigerating and Air-Conditioning Engineers, 1791 Tullie Circle N.E., Atlanta, GA 30329, U.S.A.

**A1.5** ANSI/ASHRAE Standard 41.1 – 2013 (RA 2006), *Standard Method for Temperature Measurement*, 2013, American Society of Heating, Refrigerating and Air-Conditioning Engineers, Atlanta, 1791 Tullie Circle N.E., Atlanta, GA 30329, U.S.A.

**A1.6** ANSI/ASHRAE Standard 41.3 - 1989, *Standard Method for Pressure Measurement*, 1989, American Society of Heating, Refrigerating and Air-Conditioning Engineers, 1791 Tullie Circle N.E., Atlanta, GA 30329, U.S.A.

**A1.7** ANSI/ASHRAE Standard 41.8 - 1989, *Standard Methods for Measurement of Flow of Liquids in Pipes Using Orifice Flowmeters*, 1989, American Society of Heating, Refrigerating and Air-Conditioning Engineers, 1791 Tullie Circle N.E., Atlanta, GA 30329, U.S.A.

**A1.8** ANSI/ASHRAE Standard 41.9 - 2011, *A Standard Calorimeter Test Method for Flow Measurement of a Volatile Refrigerant*, 2011, American Society of Heating, Refrigerating and Air-Conditioning Engineers, 1791 Tullie Circle N.E., Atlanta, GA 30329, U.S.A.

**A1.9** *ASHRAE Handbook Fundamentals*, Chapter 30, “Thermophysical Properties of Refrigerants” and Chapter 31, “Physical Properties of Secondary Coolants (Brines)”, 2013, American Society of Heating, Refrigerating and Air-Conditioning Engineers, 1791 Tullie Circle N.E., Atlanta, GA 30329, U.S.A.

**A1.10** *ASHRAE, Terminology*, <https://www.ashrae.org/resources--publications/free-resources/ashrae-terminology>, 2014, American Society of Heating, Refrigerating and Air-Conditioning Engineers, Inc., 1791 Tullie Circle, N.E., Atlanta, GA 30329, U.S.A.

**A1.11** ASME MFC-3M-2004 (R1990), *Measurement of Fluid Flow in Pipes Using Orifice, Nozzle, and Venturi*, 1990, American Society of Mechanical Engineers (ASME), 345 E. 47th St., New York, NY 10017, U.S.A.

**A1.12** ASME MFC-4M-1986 (R1990), *Measurement of Gas Flow by Turbine Meters*, 1990, American Society of Mechanical Engineers (ASME), 345 E. 47th St., New York, NY 10017, U.S.A.

**A1.13** ASME MFC-5M-1985 (R1994), *Measurement of Liquid Flow in Closed Conduits using Transit-Time Ultrasonic Flowmeters*, 1994, American Society of Mechanical Engineers (ASME), 345 E. 47th St., New York, NY 10017, U.S.A.

**A1.14** ASME MFC-6M-1998, *Measurement of Fluid Flow in Pipes Using Vortex Flow meters*, 1987, American Society of Mechanical Engineers (ASME), 345 E. 47th St., New York, NY 10017, U.S.A.

**A1.15** ASME MFC-11M-2006 (R1994), *Measurement of Fluid Flow by Means of Coriolis Mass Flowmeters*, 1994, American Society of Mechanical Engineers (ASME), 345 E. 47th St., New York, NY 10017, U.S.A.

**A1.16** ASME MFC-16-2014 *Measurement of Fluid Flow in Closed Conduits with Electromagnetic Flowmeters*, 2014, American Society of Mechanical Engineers (ASME), 345 E. 47th St., New York, NY 10017, U.S.A.

**A1.17** ASME Performance Test Code (PTC) 19.2 - 2010, *Instruments and Apparatus, Part 2, Pressure Measurement*, 2010, American Society of Mechanical Engineers (ASME), 345 E. 47th St., New York, NY 10017, U.S.A.

**A1.18** IEC Standard 60038, *IEC Standard Voltages*, 2009, International Electrotechnical Commission, 3, rue de Varembe, P. O. Box 131, 1211 Geneva 20, Switzerland.

**A1.19** NIST Standard Reference Database 23, 2013, *NIST Reference Fluid Thermodynamic and Transport Properties – REFPROP 9.1*, National Institute of Standards and Technology, Gaithersburg, MD 20899, U.S.A.

## **APPENDIX B. REFERENCES – INFORMATIVE**

**B1** Listed are standards, handbooks, and other publications which may provide useful information and background, but are not essential. References appearing in this appendix are not considered part of the standard.

**B1.1** AHRI Guideline T (I-P) – 2013, *Specifying the Thermal Performance of Cool Storage Equipment*, 2013, Air-Conditioning, Heating and Refrigeration Institute, 2111 Wilson Boulevard, Suite 500, Arlington, VA 22201, U.S.A.

**B1.2** ANSI/ASHRAE 30 - 1995, *Method of Testing Liquid-Chilling Packages*, 1995, American Society of Heating, Refrigerating and Air-Conditioning Engineers, 1791 Tullie Circle N.E., Atlanta, GA 30329, U.S.A.

**B1.3** ANSI/ASHRAE 64 - 2011, *Methods of Laboratory Testing Remote Mechanical-Draft Evaporative Refrigerant Condensers*, 2011, American Society of Heating, Refrigerating and Air-Conditioning Engineers, 1791 Tullie Circle N.E., Atlanta, GA 30329, U.S.A.

**B1.4** *ASHRAE Handbook HVAC - Systems and Equipment*, 2012, Chapter 51, “Thermal Storage, American Society of Heating, Refrigerating and Air-Conditioning Engineers, 1791 Tullie Circle N.E., Atlanta, GA 30329, U.S.A.

**B1.5** ASHRAE Standard 20 - 1997, *Methods of Testing for Rating Remote Mechanical-Draft Air-Cooled Refrigerant Condensers*, 1997, American Society of Heating, Refrigerating and Air-Conditioning Engineers, 1791 Tullie Circle N.E., Atlanta, GA 30329, U.S.A.

**B1.6** ASME MFC-1M-2003, *Glossary of Terms Used in the Measurement of Fluid Flow in Pipes*, 1991, American Society of Mechanical Engineers (ASME), 345 E. 47th St., New York, NY 10017, U.S.A.

**B1.7** ASME MFC-2M-1983 (R1988), *Measurement Uncertainty for Fluid Flow in Closed Conduits*, 1988, American Society of Mechanical Engineers (ASME), 345 E. 47th St., New York, NY 10017, U.S.A.

**B1.8** ASME MFC-10M-2000, *Method for Establishing Installation Effects on Flowmeters*, 1994, American Society of Mechanical Engineers (ASME), 345 E. 47th St., New York, NY 10017, U.S.A.

**B1.9** *Design Guide for Cool Thermal Storage*, 1994, American Society of Heating, Refrigerating and Air-Conditioning Engineers, 1791 Tullie Circle N.E., Atlanta, GA 30329, U.S.A.

## APPENDIX C. METHOD OF TESTING FOR RATING THERMAL STORAGE DEVICES WHICH EMPLOY THE SAME SECONDARY COOLANT FOR THE CHARGE AND DISCHARGE CYCLES – NORMATIVE

**C1** *Purpose.* The purpose of this appendix is to prescribe a method of testing to verify the performance and capacity of Thermal Storage Devices which employ the same Secondary Coolant to both charge and discharge the device.

**C1.1** *Intent.* The procedures set forth in this appendix are intended for use where adequate facilities, equipment, instrumentation and load stability can be provided.

**C1.2** *Exemptions.* This procedure is not intended for testing typical field installations where facilities, equipment, and instrumentation differ from those specified in this standard and steady state conditions are virtually impossible to achieve.

**C2** *Scope.* This method of test applies only to sensible (chilled water) and latent (ice on coil-internal melt, encapsulated ice, and Phase Change Materials) Thermal Storage Devices, as defined in Section 4 of this standard, where the same heat transfer fluid is used both to charge and discharge the device. (See other appendices for methods of testing applicable to other equipment classifications.)

**C3** *Definitions.* Definitions for this appendix are identical to those in Section 3 of this standard.

**C4** *Method of Testing.*

**C4.1** *Test Method.* The complete test shall include three individual test runs; the initial charge cycle test to determine the time required to initially charge the Thermal Storage Device, the discharge cycle test to verify the temperatures at which the Net Usable Storage Capacity of the device can be delivered, and the charge cycle test to verify the temperatures of the heat transfer fluid and the refrigeration capacity required to recharge the device. The approximate duration of the charge cycle test, the general profile of the load to be imposed on the Thermal Storage Device during the discharge cycle test, and the Net Usable Storage Capacity of the unit for that load profile shall be determined prior to the start of the test.

**C4.1.1** The initial charge cycle test shall determine the elapsed time required to bring the storage device to its fully charged condition and the minimum temperature of the heat transfer fluid attained during the cycle. It shall also determine the time weighted average inlet temperature ( $\overline{T}_3$ ), the time weighted average outlet temperature ( $\overline{T}_4$ ), the average charging rate ( $\overline{q}_{IC}$ ), and the total heat removal required ( $Q_{IC}$ ) to bring the storage device to its fully charged condition.

**C4.1.1.1** At the beginning of the initial charge test, the Thermal Storage Device shall be in a fully discharged, steady state condition as defined in Section C7.3.1.

**C4.1.1.2** The initial charge test shall employ the same average heat removal rate (Charge Rate) as the charge test (see Section C7.2.3).

**C4.1.1.3** The initial charge cycle test shall be complete when the storage device has reached the fully charged condition as defined by the manufacturer's published criteria.

**C4.1.2** The discharge cycle test shall verify that the coolant temperatures delivered by the Thermal Storage Device agree, Period by Period, with those predicted by the manufacturer's rating methodology when using as input the load profile actually imposed on the device during the test.

**C4.1.2.1** At the beginning of the discharge cycle test, the storage device shall be in its fully charged condition in accordance with the manufacturer's published criteria.

**C4.1.2.2** The discharge cycle test shall be conducted with the mixed temperature, as measured at sensor TS-1, held essentially constant  $\pm 1.8^{\circ}\text{F}$  by the temperature mixing valve TMV-1 (Figure C1) at a preset value as determined by the parties to the test, prior to the test.

**C4.1.2.3** The discharge cycle test shall be complete when the Net Usable Storage Capacity ( $Q_D$ ) claimed for the test load profile has been removed from the device. Note that as discussed in Section C9.12, some residual cooling may still remain in the Thermal Storage Device at this point since the duration of the discharge cycle test is solely a function of the Net Usable Storage Capacity, not the state of charge of the Thermal Storage Device.

**C4.1.3** The charge cycle test shall verify that the temperatures of the heat transfer fluid required to recharge the device agree, Period by Period, with those predicted by the manufacturer's rating methodology when using as input the chiller capacity actually delivered during the test. It shall also determine the time weighted average inlet temperature ( $\overline{T}_3$ ), the time weighted average outlet temperature ( $\overline{T}_4$ ), the average charging rate ( $\overline{q}_{ch}$ ), and the total heat removal required ( $Q_{Ch}$ ) to bring the storage device to its fully charged condition.

**C4.1.3.1** At the beginning of the charge cycle test, the storage device shall be in the state of discharge reached at the end of the discharge cycle test as described in Section C4.1.2.3 above.

**C4.1.3.2** The charge cycle test shall be complete when the storage device has been returned to its initial fully charged condition as defined in Section C4.1.1.3.

**C4.2** *Data to be Taken.* The following data shall be measured and recorded at Intervals not exceeding five minutes over the duration of the above described initial charge, charge, and discharge cycle tests.

**C4.2.1** The flow rate of the heat transfer fluid (Secondary Coolant) flowing through:

**C4.2.1.1** The test apparatus as measured at FM-1 (Figure C1)

**C4.2.1.2** The storage device as measured at FM-2 (Figure C1)

**C4.2.2** The temperatures of the heat transfer fluid (Secondary Coolant):

**C4.2.2.1** As it enters and leaves the Thermal Storage Device at TS-3 and TS-4 (Figure C1)

**C4.2.2.2** At confirming measurement points TS-1 and TS-2 (Figure C1)

**C4.2.3** The temperature of the Ambient Air ( $T_{amb}$ ) surrounding the Thermal Storage Device.

**C4.2.4** The pressure drop of the heat transfer fluid across the Thermal Storage Device ( $\Delta PS-1$  Figure C1).

**C4.2.5** The power input to any auxiliary equipment such as air pumps, agitators, etc. that are required by the storage device to produce the rated capacity during the charge or discharge cycle test.

**C4.2.6** One measurement of the refractive index of any Secondary Coolant during each discharge and charge cycle test.

**C5** *Instruments.*

**C5.1** *General.* Instruments and multi-component measurement systems shall be selected and calibrated to meet the requirements and accuracies specified in the following subsections.

**C5.1.1** Instrument calibrations shall be traceable to primary or secondary standards calibrated by the National Institute of Standards and Technology. The indicated corrections shall be applied to obtain the required accuracy. Instruments shall be calibrated on a regular schedule appropriate for the respective instruments, and full calibration records shall be maintained.

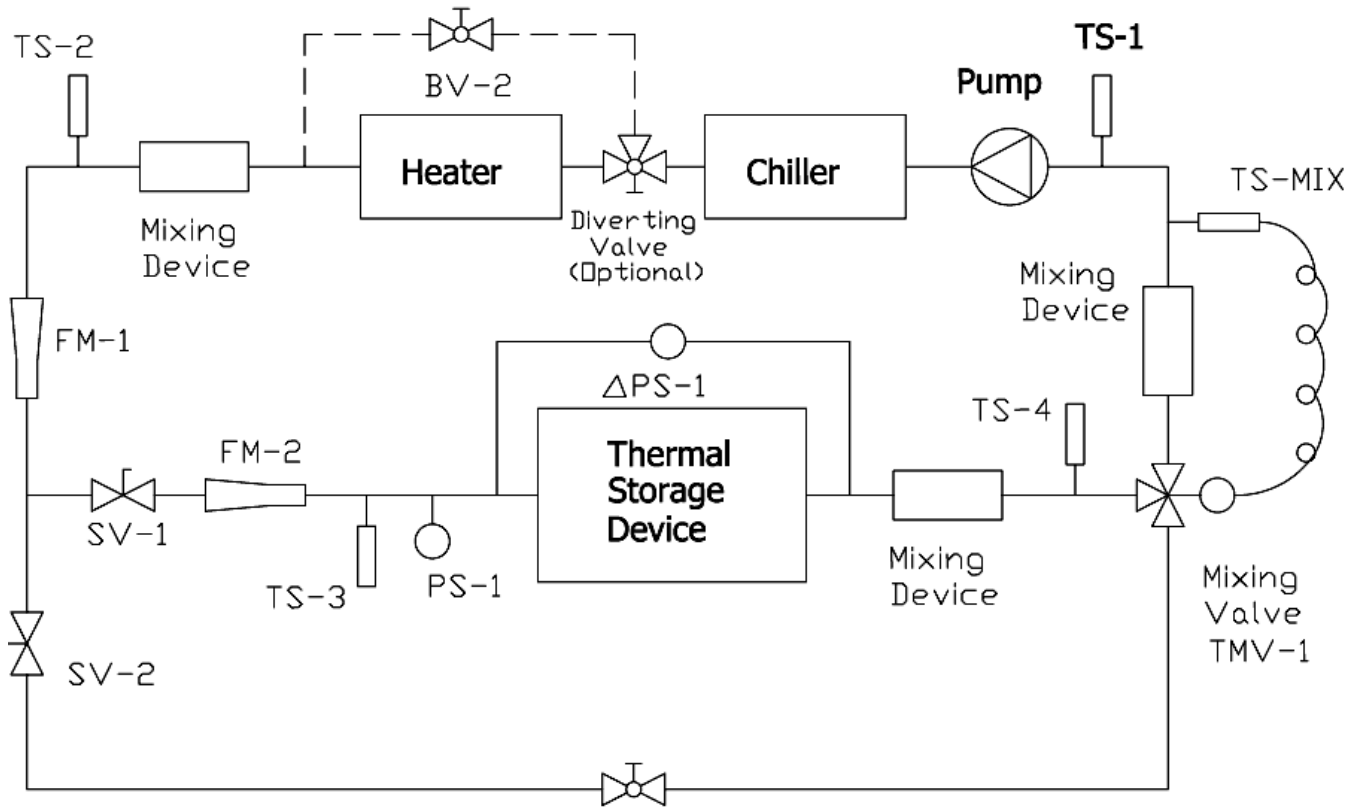

**Figure C1. Thermal Storage Device Test Apparatus**

**Legend:**

- |                                   |   |
|-----------------------------------|---|
| BV = Balancing Valve              | SV = Shut-Off Valve                     |
| ΔPS= Differential Pressure Sensor | TMV = Temperature Actuated Mixing Valve |
| FM = Flow meter                   | TS = Temperature Sensor                 |
| PS = Pressure Sensor              |   |

**C5.1.2** All instruments shall be applied and used in accordance with the standards specified for that type of instrument and in a manner that ensures compliance with the specified accuracy.

**C5.2** *Temperature Measurements.* Temperature measurements shall be made in accordance with ANSI/ASHRAE Standard 41.1 with instruments having accuracies within the limits specified for the following measurements:

**C5.2.1** Individual temperatures of water and other heat transfer fluids, or air dry-bulb temperatures:  $\pm 0.10^{\circ}\text{F}$

**C5.2.2** Temperature differences in heat transfer fluids within 2% of the numerical value of the difference being measured

**C5.3** *Pressure Measurements.* Pressure measurements shall be made in accordance with ANSI/ASHRAE Standard 41.3 and ASME PTC 19.2. The accuracy of instruments for measuring the pressure of fluids and the pressure differential across the Thermal Storage Device shall permit determination of the pressure or pressure differential within 2% of the numerical value of the quantity being measured.

**C5.4** *Electrical Measurements and Instruments.* Electrical measurements shall be made at a location such that the instrumentation can accurately measure the total power input to the device. Instrumentation used shall measure the true rms power within an accuracy of 1% of the quantity measured. Test facilities that utilize power-altering equipment may require appropriate isolation and precautions between the measurement point and the load device to ensure that accurate power measurements are obtained.

**C5.5** *Flow Measurements.* Flow rates of heat transfer fluids (including refrigerants) shall be measured in accordance with ASHRAE Standard 41.8 and the standard listed below for the instrument being used. Instruments shall have accuracies within 1% of the quantity measured. The instruments that may be used to measure the flow of heat transfer fluids include the following:

Coriolis Meters	ASME MFC-11M
Electromagnetic Meters	ASME MFC-16
Flow Nozzles	ASME MFC-3M
Orifices	ASME MFC-3M
Turbine Meters	ASME MFC-4M
Ultrasonic Meters	ASME MFC-5M
Venturi Meters	ASME MFC-3M
Vortex Meters	ASME MFC-6M

**C5.6** *Time Measurements.* Time measurements shall be made with instruments having accuracies within 0.5% of the elapsed time measured. This accuracy will include any uncertainty errors associated with starting and stopping the instrument.

**C5.7** *Physical and Thermodynamic Properties.* The physical and thermodynamic properties of fluids shall be determined from the following sources:

**C5.7.1** The heat transfer and thermodynamic properties of water shall be taken from the *ASHRAE Handbook Fundamentals*.

**C5.7.2** The heat transfer and thermodynamic properties of Secondary Coolants shall be taken from the *ASHRAE Handbook Fundamentals*, based on the refractive index measurements taken during the test(s).

**C5.7.2.1** Refractive index measurements shall be converted to concentration (in percent by volume) of the heat transfer fluid using standard conversion tables.

**C5.7.2.2** The properties shall be interpolated from the data published in *ASHRAE Handbook Fundamentals*, at the concentration corresponding to the measured refractive index and a temperature representative of the fluid at the point of interest.

**C6** *Apparatus.*

**C6.1** *Configuration.* The test apparatus shall be comprised, as a minimum, of all the equipment shown on Figure C1 with the position of the Thermal Storage Device relative to the balance of the testing apparatus as shown. The apparatus may be of open or closed loop design.

**C6.2** *Piping for Heat Transfer Fluid.* The piping to which the differential pressure measuring device ( $\Delta$ PS-1) is connected shall be of the same diameter on both the inlet and the outlet of the Thermal Storage Device.

**C6.3** *Insulation.* The piping between temperature measuring points TS-2 and TS-3, TS-4 and TS-1, and the full length of the by-pass loop shall be sufficiently insulated to minimize the heat losses that would otherwise affect the validity of the primary and confirming capacity measurements.

**C7** *Test Procedure.*

**C7.1** *Preparation for Test.*

**C7.1.1** The storage device shall be installed in the test loop as shown in Figure C1 in accordance with the manufacturer's installation instructions. If located outdoors, the storage device shall be shielded from direct sunlight and protected from winds.

**C7.1.2** After installation and before testing, the unit shall be cycled (charged and discharged) as recommended by the manufacturer.

**C7.2** *Test Requirements and Operational Limits.*

**C7.2.1** The duration of the charge cycle test and the load profile of the discharge cycle test shall be determined prior to the start of the test.

**C7.2.2** Steady state flow of the heat transfer fluid, as measured at FM-1 (Figure C1), shall be maintained over the duration of each test cycle. It shall be considered achieved if the measured flow rate varies less than  $\pm 10\%$  over the duration of any given initial charge, charge or discharge cycle test.

**C7.2.3** The initial charge test and the charge cycle test shall employ the same average heat removal rate (Charge Rate) over the duration of the test, the value of which shall be within 10% of the rate specified prior to the test. The capacity of the compression equipment shall not be mechanically altered during either test or between tests. For the tests to be valid, the average heat removal rate of the initial charge cycle test shall be within 10% of the average heat removal rate of the charge cycle test.

**C7.2.4** The duration of the discharge cycle test and the profile of the load imposed on the Thermal Storage Device shall be determined prior to the start of the test. The duration of the discharge cycle test shall be within 10% of the time specified.

**C7.2.5** The total heat removed from the Thermal Storage Device during the initial charge cycle test ( $Q_{IC}$ ) or the charge cycle test ( $Q_{Ch}$ ), and added to the device during the discharge cycle test ( $Q_D$ ) shall be determined using the flow rate of the heat transfer fluid as measured at FM-2 and the temperatures of the heat transfer fluid as measured at sensors TS-3 and TS-4. After correcting the calculated values for ambient and parasitic heat gains ( $Q_{amb}$  and  $Q_{paras}$ ), the total heat input during the discharge cycle test shall be within 5% of the total heat removed during the charge cycle test.

**C7.2.6** The confirming test of the discharge cycle test shall consist of measuring and recording the flow rate and temperatures of the heat transfer fluid at flow meter FM-1 and temperature sensors TS-1 and TS-2 and using these values to calculate the total heat added to the storage device over the duration of the discharge cycle test, as specified in Section C7.2.5. For the discharge cycle test to be valid, the result of this confirming test shall agree within 3% of the primary test value.

**C7.2.7** The confirming test of the charge cycle test shall consist of measuring and recording the flow rate and temperatures of the heat transfer fluid at flow meter FM-1 and temperature sensors TS-1 and TS-2 and using these values to calculate the total heat removed from the storage device over the duration of the charge cycle test, as specified in Section C7.2.5. For the charge cycle test to be valid, the result of the confirming test shall agree within 3% of the primary test value.

**C7.3** *Test Sequence.* A full test shall consist of an initial charge cycle test, a discharge cycle test, and a charge cycle test, conducted in the following sequence:

**C7.3.1** *Initial Steady State Condition.* With the Thermal Storage Device in the fully discharged condition and valve SV-2 fully closed, the heat transfer fluid shall be circulated through the test apparatus loop and the Thermal Storage Device until the initial steady state conditions are established. Initial steady state shall be considered achieved when the temperatures measured at TS-1, TS-2, TS-3, and TS-4 are equal to or greater than 13°F above the phase change temperature of the storage media for a period of 15 minutes.

**C7.3.2** *Changeover Period I.* During this and all subsequent Changeover Periods, secondary sources of heat (such as auxiliary heaters, agitation systems in the Thermal Storage Device, etc.) shall be turned off. During this first changeover Period, the flow rates and valves shall be adjusted for the initial charge cycle test. When all components are set, the chiller shall be turned on.

**C7.3.3** *Initial Charge Cycle Test.* The initial charge cycle test shall be conducted at an average Charge Rate which shall be within 10% of the average rate used during the charge cycle test, see Section C7.2.3, with no mechanical unloading of the compressor during the test. During the initial charge cycle test, any agitation devices or other auxiliary equipment furnished with the device shall be operated in accordance with the manufacturer's published instructions. The initial charge cycle test shall end when the storage device is fully charged in accordance with the manufacturer's published instructions.

**C7.3.4** *Changeover Period II.* Immediately after the initial charge cycle test, with the Thermal Storage Device fully charged, the valve settings shall be adjusted to fully by-pass the Thermal Storage Device and to set the flow rate of the heat transfer fluid for the discharge cycle test.

**C7.3.5** *Discharge Cycle Test.* The discharge cycle test begins when the heat source and the temperature modulating valve, TMV-1, are activated. During this discharge cycle test, any agitation devices normally furnished with the Thermal Storage Device shall be operated in accordance with the manufacturer's published instructions. The discharge cycle test ends when the Net Usable Storage Capacity ( $Q_D$ ) claimed for the device has been removed, at which point the heat source is deactivated.

**C7.3.6** *Changeover Period III.* Upon completion of the discharge cycle test, flow through the storage device shall be stopped and immediately by-passed around the storage device for the duration of this changeover Period. During this Period, the flow rates and valves shall be adjusted for the charge cycle test. When all components are set, the chiller shall be turned on.

**C7.3.7** *Charge Cycle Test.* The charge cycle test shall be started by immediately changing valves to divert full flow of the heat transfer fluid through the storage device. During this charge cycle test, a constant Charge Rate (i.e. no mechanical unloading of the compressor throughout the test, as defined in Section C7.2.3, shall be maintained and any agitation devices normally furnished with the Thermal Storage Device shall be operated in accordance with the manufacturer's published instructions. The charge cycle test shall end when the unit is fully charged as defined by the manufacturer's published instructions.

**C8** *Data To Be Recorded.*

**C8.1** *Test Data.* The following test data shall be measured and recorded at evenly spaced Intervals not exceeding five minutes in duration over the full duration of all initial charge cycle, charge cycle and discharge cycle tests.

- C8.1.1** Temperature of the heat transfer fluid at locations TS-1, TS-2, TS-3, and TS-4, °F
- C8.1.2** Temperature of the Ambient Air,  $T_{amb}$ , °F
- C8.1.3** Flow rate of the heat transfer fluid at locations FM-1 and FM-2, gpm
- C8.1.4** Differential pressure of the heat transfer fluid across the Thermal Storage Device,  $\Delta PS-1$ , psi
- C8.1.5** Time the test cycle was initiated and completed
- C8.1.6** The pressure at sensor PS-1, psi

**C8.2** *Test Data for Auxiliaries.* If liquid pumps, air pumps, or other types of energy input are required for the proper operation of the storage device, the following additional data shall be recorded at evenly spaced Intervals not exceeding 30 minutes in duration.

- C8.2.1** Power consumption of accessory pump or air compressor, kW
- C8.2.2** The duration of operation if less than the full test cycle, h
- C8.2.3** Temperature of supply liquid or air to any such accessories, °F
- C8.2.4** Flow rate of liquid, gpm or air, cfm



**C8.3** *Data of Record.* The following data of record shall be included in the test report:

- C8.3.1** Date, place and time of test
- C8.3.2** Names of test supervisors, technicians, and witnessing personnel

**C8.4** *Thermal Storage Unit Data.* The following product data shall be included in the test report:

- C8.4.1** Manufacturer's name and address
- C8.4.2** Model number, serial number, and all nameplate data of the Thermal Storage Device
- C8.4.3** Manufacturer's Net Usable Storage Capacity, ton-hour
- C8.4.4** Storage medium
- C8.4.5** A description of the Secondary Coolant used to charge and to discharge the Thermal Storage Device, including:
  - C8.4.5.1** Name of the manufacturer
  - C8.4.5.2** Name/description of the heat transfer fluids
  - C8.4.5.3** Refractive index of glycol based Secondary Coolants
  - C8.4.5.4** Density of Secondary Coolants at 60°F, lb/ft<sup>3</sup>
  - C8.4.5.5** Specific heat of Secondary Coolants at 60°F, Btu/lb · °F
- C8.4.5** Overall dimensions of the Thermal Storage Device, in
- C8.4.5** Materials of construction of heat exchanger and/or storage vessel
- C8.4.6** Maximum operating pressure of the heat exchanger and/or storage vessel, psi
- C8.4.7** Maximum operating temperature of the heat exchanger and/or storage vessel, °F
- C8.4.8** Maximum allowable flow rate of heat transfer fluid(s), gpm
- C8.4.9** Minimum allowable flow rate of heat transfer fluid(s), gpm
- C8.4.10** The quantity and type of auxiliaries (including agitation devices if employed) and the power requirements and nameplate data for each

**C9** *Calculation of Results.*

**C9.1** *Nomenclature, Symbols, and Subscripts.*

Symbols:

- $c_p$  = Specific heat at constant pressure, Btu/lb · °F
- $h_{source}$  = The enthalpy of the air being used to agitate the storage media in a Thermal Storage Device, at the source temperature and humidity, Btu/lb moist air
- $h_{sat}$  = The enthalpy of saturated air at the temperature of the storage media in a Thermal Storage Device, Btu/lb moist air
- $K_i$  = A constant as may be required to correct for units of measure
- $\dot{m}_{air}$  = The mass flow rate of air used to agitate the storage media in a Thermal Storage Device, lb/h
- $n$  = The number of test readings taken during each Period comprising a test cycle
- $p$  = The number of Periods comprising a test cycle
- $P_{Ch\ paras}$  = The shaft power of a parasitic device operating during the charge cycle test, tons
- $P_{D\ paras}$  = The shaft power of a parasitic device operating during the discharge cycle test, tons
- $Q_{air}$  = The calculated heat input to a Thermal Storage Device from air used to agitate the storage media, ton-hour
- $Q_{amb}$  = The calculated heat input to the Thermal Storage Device from the ambient over the duration of the charge cycle test and discharge cycle test, ton-hour
- $Q_{Ch}$  = Total charge capacity, ton-hour
- $Q_D$  = Net Useable Storage Capacity, ton-hour
- $Q_{IC}$  = Initial charge capacity, as determined from the initial charge cycle test, ton-hour

$Q_{\text{paras}}$	=	The calculated heat input to the Thermal Storage Device from parasitic devices operating during the charge cycle test and discharge cycle test, ton-hour
$q_{\text{amb}}$	=	The rate of heat gain from the ambient into the Thermal Storage Device at a specified temperature difference between the ambient and thermal storage media, tons
$\overline{q}_{\text{Ch}}$	=	The average Charge Rate over the duration of the charge cycle test, tons
$\overline{q}_{\text{IC}}$	=	The average Charge Rate over the duration of the initial charge cycle test, tons
$\overline{q}_{\text{Ch}_p}$	=	The average Charge Rate for one of the individual Periods (p) (consisting of Intervals 1 through n) comprising the charge cycle test, tons
$\overline{q}_{\text{D}_p}$	=	The average Discharge Rate for one of the individual Periods (p) (consisting of Intervals 1 through n) comprising the discharge cycle test, tons
$T_{\text{amb}}$	=	The temperature of the Ambient Air surrounding the Thermal Storage Device, °F
$\Delta T_{\text{des}}$	=	The design temperature difference between the ambient and the storage media for which the value of the heat gain rate ( $q_{\text{amb}}$ ) is valid, °F
$T_n$	=	Temperature measured at the temperature sensor with the same numeric designation, i.e. TS-n, °F
$\overline{T}_n$	=	The time weighted average temperature measured at the temperature sensor with the same numeric designation, i.e. TS-n, °F
$T_{\text{sm}}$	=	The temperature of the storage media in the Thermal Storage Device, °F
$t_{\text{Ch}_i}$	=	Time at start of Charge Cycle
$t_{\text{Ch}_F}$	=	Time at finish of Charge Cycle
$t_{\text{D}_i}$	=	Time at start of Discharge Cycle
$t_{\text{D}_F}$	=	Time at finish of Discharge Cycle
$t_{\text{IC}_i}$	=	Time at start of initial Charge Cycle
$t_{\text{IC}_F}$	=	Time at finish of initial Charge Cycle
$\tau_{\text{Ch}}$	=	Duration of the charge cycle test, h
$\tau_{\text{Ch paras}}$	=	Total Period of operation of a parasitic device during the charge cycle test, h
$\tau_{\text{D}}$	=	Duration of the discharge cycle test, h
$\tau_{\text{D paras}}$	=	Total Period of operation of a parasitic device during the discharge cycle test, h
$\tau_{\text{IC}}$	=	Duration of the initial cycle test, h
$W_{\text{FM-n}}$	=	The mass flow rate of the heat transfer fluid measured at the flow meter with the same numeric designation, i.e. FM-n, lb/min

Subscripts:

Ch	=	Designates the value pertains to a Charge Cycle
D	=	Designates the value pertains to a Discharge Cycle
IC	=	Designates the value pertains to an initial Charge Cycle
paras	=	Designates the value pertains to a parasitic device such as an air pump
primary	=	Designates primary test
confirm	=	Designates confirming test

**C9.2 Averaging.** The test readings of temperature, flow rate, pressure, etc. taken at each of the Intervals comprising a Period of the test cycle shall be averaged and used as the value for that Period.

**C9.3 Initial Charge Capacity.** The initial Charge Capacity ( $Q_{IC}$ ) is equal to the heat removed from the Thermal Storage Device during the initial charge cycle test, less the heat gains from parasitic and the ambient over the duration of the initial Charge Cycle. It is calculated as:

$$Q_{IC} = [(K_1) \int_{t_{IC1}}^{t_{ICF}} W_{FM-2} c_p (T_4 - T_3) dt] - Q_{paras} - Q_{amb} \quad C1$$

**C9.4 Net Usable Storage Capacity.** The Net Usable Storage Capacity ( $Q_D$ ) is equal to the heat absorbed by the Thermal Storage Device during the discharge cycle test. For the primary test, it is calculated as:

$$Q_D = Q_{D_{primary}} = (K_1) \int_{t_{D1}}^{t_{DF}} W_{FM-2} c_p (T_3 - T_4) dt \quad C2$$

and for the confirming test:

$$Q_{D_{confirm}} = (K_1) \int_{t_{D1}}^{t_{DF}} W_{FM-1} c_p (T_2 - T_1) dt \quad C3$$

For the test to be valid, the following relationship shall hold:

$$\left| \frac{Q_{D_{confirm}}}{Q_{D_{primary}}} - 1 \right| \leq 0.03 \quad C4$$

**C9.5 Average Discharge Rate.** Determine the average Discharge Rate for each Period (p) (consisting of Intervals 1 through n) comprising the discharge cycle test as:

$$\overline{q_{Dp}} = (K_1) \left( \frac{1}{n} \right) \sum_{i=1}^n W_{FM-2n} c_p (T_{3n} - T_{4n}) \quad C5$$

**C9.6 Parasitic Heat Gain.** The parasitic heat gain into the Thermal Storage Device during the charge cycle test and the discharge cycle test ( $Q_{paras}$ ) is determined as:

$$Q_{paras} = (K_1) [(\tau_{Ch paras}) (P_{Ch paras}) + (\tau_{D paras}) (P_{D paras})] \quad C6$$

Also, if the parasitic auxiliary is an air pump used for agitation of the storage media, the parasitic heat gain shall include the heat input to the Thermal Storage Device as the air is cooled from its source temperature to the temperature of the storage media:

$$Q_{air} = (K_1) (\dot{m}_{air}) (h_{source} - h_{sat}) \quad C7$$

**C9.7 Ambient Heat Gain.** The ambient heat gain into the Thermal Storage Device during the charge cycle and discharge cycle tests ( $Q_{paras}$ ) is determined as:

$$Q_{amb} = (K_1) (\tau_{Ch} + \tau_D) (q_{amb}) \left( \frac{T_{amb} - T_{sm}}{\Delta T_{des}} \right) \quad C8$$

**C9.8 Total Charge Capacity.** The total Charge Capacity ( $Q_{Ch}$ ) shall be calculated as follows:

$$Q_{Ch} = Q_{Ch_{primary}} \quad C9$$

$$Q_{Ch_{primary}} = (K_1) \int_{t_{Ch1}}^{t_{ChF}} W_{FM-2} c_p (T_4 - T_3) dt$$

and for the confirming test calculation:

$$Q_{Ch_{confirm}} = (K_1) \int_{t_{Ch1}}^{t_{ChF}} W_{FM-1} c_p (T_1 - T_2) dt \quad C10$$

Then, for the test to be valid, the following two relationships shall hold:

$$\left| \frac{Q_{Ch_{confirm}}}{Q_{Ch_{primary}}} - 1 \right| \leq 0.03 \quad C11$$

$$\left| \frac{Q_D + Q_{amb} + Q_{paras}}{Q_{Ch_{primary}}} - 1 \right| \leq 0.10 \quad C12$$

**C9.9 Average Charge Rate.** The average Charge Rate ( $\overline{q_{Ch_p}}$ ) for each Period comprising the Charge Cycle shall be calculated as:

$$\overline{q_{Ch_p}} = (K_1) \left( \frac{1}{n} \right) \sum_{i=1}^n W_{FM-2_n} c_p (T_{4_n} - T_{3_n}) \quad C13$$

The average Charge Rate over the duration of the Charge Cycle as:

$$\overline{q_{Ch}} = \left( \frac{Q_{Ch_{primary}}}{\tau_{Ch}} \right) \quad C14$$

and the average Charge Rate over the duration of the initial Charge Cycle as:

$$\overline{q_{IC}} = \left( \frac{Q_{IC}}{\tau_{IC}} \right) \quad C15$$

For the initial Charge Cycle test to be valid, the following relationship shall hold:

$$\left| \frac{\overline{q_{IC}}}{\overline{q_{Ch}}} - 1 \right| \leq 0.10 \quad C16$$

**C9.10 Average Charge Temperatures.** The average charge temperatures, will be the time weighted average of the entire Charge Period.

**C9.10.1** For Thermal Storage Devices using a Secondary Coolant for the heat transfer fluid during the charging cycle, the average entering and leaving temperatures shall be calculated as follows:

$$\overline{T}_3 = \left( \frac{1}{\tau_{Ch}} \right) \int_{t_{ChI}}^{t_{ChF}} T_3 dt \tag{C17}$$

$$\overline{T}_4 = \left( \frac{1}{\tau_{Ch}} \right) \int_{t_{ChI}}^{t_{ChF}} T_4 dt \tag{C18}$$

**C9.11** *Minimum Charge Temperature.* The minimum charge temperature is the lowest temperature of the Charge Fluid (as measured at TS-3) that was required during the Charge Cycle (normally the temperature when the charge test was terminated).

**C9.12** *Initial Charge Time.* The initial charge time shall be equal to the time elapsed between the start and the end of the initial charge test. These data are required since the time required to initially charge the device may be longer than that required to recharge it because in some storage devices a residual charge shall be left in the device for it to perform properly. Therefore, it is important to know the time required to initially charge the device or to recharge it, if for some reason, the device is totally discharged when in normal operation.

**C10** *Test Evaluation.*

**C10.1** *Procedure.* The thermal performance of the Thermal Storage Device shall be evaluated by comparing the measured test data average over each Period comprising the test cycle to the performance predicted by the manufacturer's rating methodology for the corresponding Period.

**C10.1.1** *Charge Cycle Test.* Using the average Charge Rate from Section C9.9 as the chiller capacity and the measured flow rate of the heat transfer fluid as input, determine the temperatures of the charging fluid entering and leaving the Thermal Storage Device as predicted by the manufacturer's rating methodology.

For the charge rating to be verified, the measured fluid temperatures averaged for each Period of the charge cycle test and the minimum fluid temperature attained during the test cycle shall be no lower than 0.5°F below the corresponding values predicted by the rating methodology for that Period.

**C10.1.2** *Discharge Cycle Test.* Using the average Discharge Rate for each Period of the Discharge Cycle test, as determined from Section C9.5, as the load profile, and the corresponding measured flow rate of the heat transfer fluid as input for each Period, determine the temperatures of the Discharge Fluid entering and leaving the Thermal Storage Device for each Period, as predicted by the manufacturer's rating methodology.

For the discharge rating to be verified, the measured fluid temperatures averaged over each Period of the Discharge Cycle shall be no higher than 0.5°F above those values predicted by the rating methodology for that Period.

**C11** *Test Report.*

**C11.1** *General Information.* A written test report shall be prepared and distributed to the parties involved in the test. Included in the introduction to the report shall be:

- C11.1.1** The name and address of the testing facility
- C11.1.2** The name(s), title(s) and affiliation(s) of those persons conducting the test, witnessing the test, and preparing the test report. Also included shall be the name, title, and signature of the person(s) accepting responsibility for the content of the report
- C11.1.3** The date the test was conducted and the date of the report
- C11.1.4** The name and address of the client
- C11.1.5** The method by which the test unit was selected (i.e. random selection) and its conditions

**C11.2** *Test Unit Description.* The report shall include a full description of the test unit, using as a minimum the data specified in Section C8.4.

**C11.3 Test System Description.** A description of the test facility and primary apparatus shall be included in the report complete with a system diagram showing the interconnecting piping and the locations of the principle components and instrumentation. Also included in this section shall be the specifics of the heat transfer fluid(s) employed for the test, including the basic data specified in Section C8.3.

**C11.4 Test Unit Data.** The report shall include a summary of the unit performance with the following overall data and calculation results:

**C11.4.1** The Net Usable Storage Capacity ( $Q_D$ ), ton-hour

**C11.4.2** The type of heat transfer fluid used

**C11.4.3** The duration of the initial Charge Cycle, h

**C11.4.4** The average Charge Rate ( $\overline{q_{IC}}$ ) for the initial Charge Cycle, tons

**C11.4.5** The time weighted inlet and outlet temperatures over the duration of the cycle, °F

**C11.4.6** The minimum temperature attained by the heat transfer fluid, °F

**C11.4.7** The total capacity ( $Q_{IC}$ ) for the initial Charge Cycle, ton-hour

**C11.4.8** The duration of the Discharge Cycle, h

**C11.4.9** The average Discharge Rate ( $\overline{q_{Dp}}$ ), tons

**C11.4.10** The maximum temperature attained by the heat transfer fluid leaving the storage device during the Discharge Cycle, °F

**C11.4.11** The duration of the Charge Cycle, h

**C11.4.12** The average Charge Rate ( $\overline{q_{Ch}}$ ), tons

**C11.4.13** The time weighted inlet and outlet temperatures over the duration of the cycle, °F

**C11.4.14** The minimum temperature attained by the heat transfer fluid, °F

**C11.4.15** The total capacity ( $Q_{Ch}$ ) of the Charge Cycle, ton-hour

**C11.4.16** The pressure drop of the heat transfer fluid across the Thermal Storage Device at the maximum flow rate, psi

**C11.4.17** A copy of the performance of the Thermal Storage Device as predicted by the manufacturer's rating methodology when using the duration of the charge cycle test and the load profile imposed during the discharge cycle test as input

**C11.4.18** Tables for both the Charge Cycle and the Discharge Cycle comparing the measured temperatures of the heat transfer fluid as it enters and leaves the Thermal Storage Device, averaged over each Period, to the temperature predicted by the rating methodology for the corresponding Period. (Table C1)

**C11.5 Calculation Summary.** The report shall include a summary sheet showing the results of all calculations for each reading along with an example of the complete calculations for one set of readings. Also included in this section shall be a statement of compliance with or deviation from the provisions in this standard.

**C11.6 Raw Test Data.** The raw test data shall be compiled and recorded in a legible form and included in the report. Hard copy shall be included even if data are also stored on electronic media.

**C11.7 Instrument Summary.** The report shall include a tabulation of all instruments used in the test, including the serial number, latest calibration date, and the means by which the instrument was calibrated.

Table C1. Temperature Comparison – Charge and Discharge Cycles							
Period	Charge or Discharge Rate, q, tons	Temperature of Heat Transfer Fluid Entering Storage Device, °F			Temperature of Heat Transfer Fluid Leaving Storage Device, °F		
		Measured	Predicted	Difference	Measured	Predicted	Difference
#1							
#2							
#...							
#p							

# APPENDIX D. METHOD OF TESTING FOR RATING UNITARY THERMAL STORAGE SYSTEMS – NORMATIVE

**D1** *Purpose.* The purpose of this appendix is to prescribe a method of testing to verify the performance and capacity of a Unitary Thermal Storage System (UTSS).

**D1.1** *Intent.* The procedures set forth in this appendix are intended for use in situations where adequate facilities, equipment, instrumentation and load stability can be provided.

**D1.2** *Exemptions.*

**D1.2.1** This procedure is not intended for testing typical field installations where facilities, equipment, and instrumentation differ from that specified in this standard and steady state conditions are virtually impossible to achieve.

**D1.2.2** This procedure is not intended for testing a UTSS which utilizes water-cooled or evaporative condensers.

**D2** *Scope.* This method of test applies only to a latent UTSS, as defined in Section 4 of this standard, where, for example, an evaporating refrigerant is used as the heat transfer fluid during both the charge and discharge cycles. (See other appendices for methods of testing applicable to other equipment classifications)

**D3** *Definitions.* Definitions for this appendix are identical to those in Section 3 of this standard.

**D4** *Method of Testing.*

**D4.1** *Test Method.* Two separate tests shall be performed to determine UTSS performance. Charge cycle test measurements shall be used to determine UTSS charge performance and discharge cycle test measurements shall be used to determine UTSS discharge performance as stated below.

**D4.1.1** *Charge Cycle Test.* The Charge Cycle Test shall consist of five complete charge/discharge cycles performed at each rating condition set forth in Table 4. The tests will determine the average Charge Rate and power input of the UTSS by measuring the net heat absorbed during the Discharge Period and the power input during the Charge Period.

**D4.1.1.1** During the Charge Period of the test, the UTSS shall be run at full capacity for the duration of the test. The charging portion of this test shall determine the power input of the UTSS.

**D4.1.1.1.1** At the beginning of the Charge Period, the UTSS shall be in the fully discharged, steady state condition as defined in Section D4.1.1.2.1

**D4.1.1.1.2** The Charge Period shall be complete when the UTSS has reached the fully charged condition as defined by the manufacturer's published criteria.

**D4.1.1.2** During the Discharge Period of the test, the Measured Storage Capacity shall be determined and used to calculate the total charge capacity and average Charge Rate for the UTSS.

**D4.1.1.2.1** The Discharge Period for a UTSS using a refrigerant as the Discharge Fluid shall be complete when the Saturated Return Temperature to the UTSS as determined from PS-1 is equal to the maximum allowable temperature specified, but not less than 15°F above the phase change temperature of the storage media.

The Discharge Period for a UTSS using secondary coolants as the Discharge Fluid shall be complete when the leaving fluid temperature from the UTSS as measured at TS-5 is equal to the maximum allowable temperature specified, but not less than 15°F above the phase change temperature of the storage media.



**D4.1.1.2.2** Under no conditions shall the Discharge Period be completed before all the ice in the tank has been melted. The UTSS shall be discharged at the maximum design Discharge Rate specified by the manufacturer until 90% of the Net Usable Storage Capacity has been removed, at which point the Discharge Rate shall be reduced to 50% of the maximum design Discharge Rate until the conditions defined in Section D4.1.1.2.1 are attained.

**D4.1.2 Discharge Cycle Test.** The discharge cycle test shall verify that the temperatures at which the Net Usable Storage Capacity of the UTSS is delivered for a specific imposed load agree, Period by Period, with those predicted by the manufacturer's Published Rating methodology when using the test load profile as input.

**D4.1.2.1** The UTSS shall be fully charged by a single Charge Period performed within the temperature range specified in Table 4 and in accordance with the manufacturer's published criteria.

**D4.1.2.2** The Discharge Period test shall be conducted with the modulating 3-way valve controlled to impose the predetermined load profile for the test (Figure D1).

**D4.1.2.3** The Discharge Period shall be complete when the Net Usable Storage Capacity ( $Q_D$ ) claimed for the imposed load profile has been removed from the device. (Note: As discussed in Section D9.5, some residual cooling may still remain in the UTSS at this point since the duration of the discharge cycle test is solely a function of the Net Usable Storage Capacity ( $Q_D$ ) not the state of charge of the UTSS)

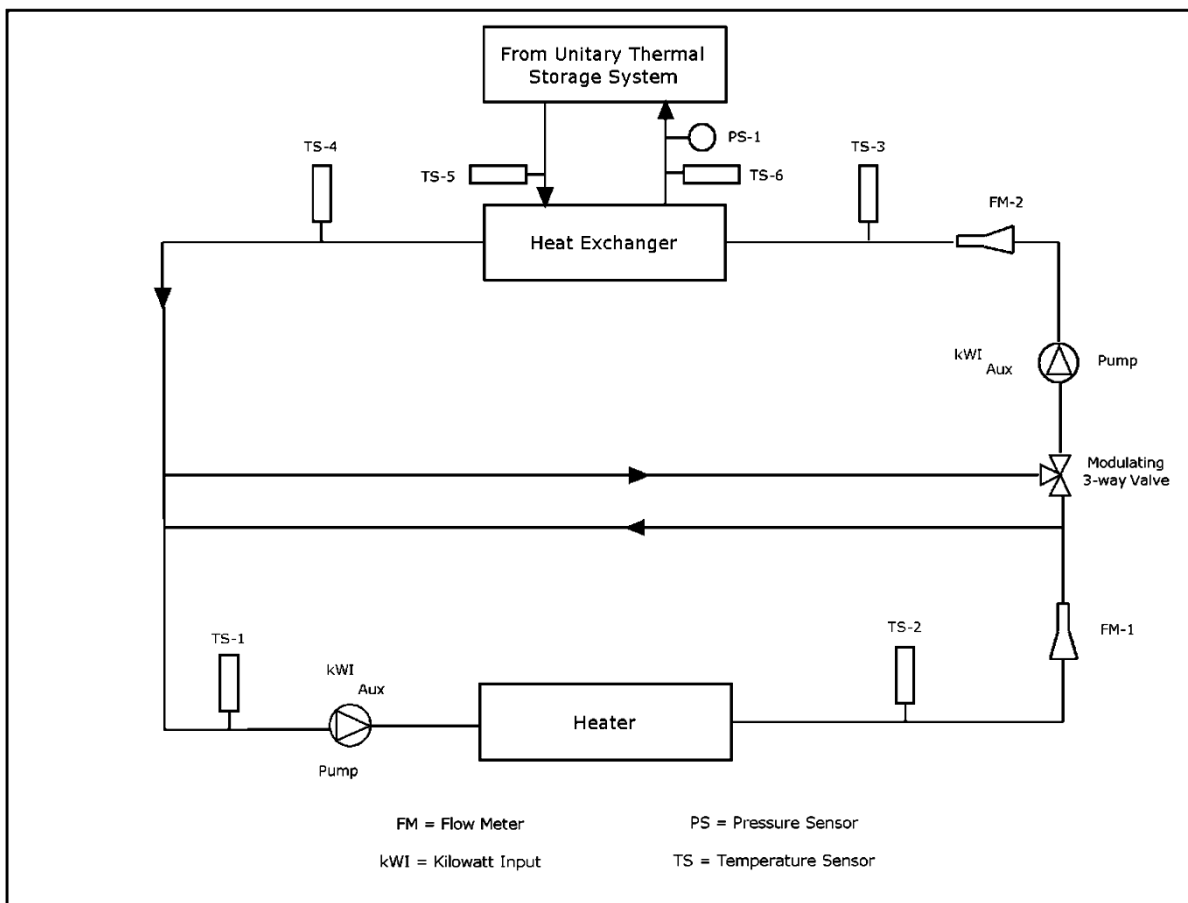

**Figure D1. Discharge Cycle Test Apparatus**

**D4.2** *Data to be Taken.* The following data shall be measured and recorded at Intervals not exceeding 5 minutes over the duration of each test.

**D4.2.1** *Charge Cycle Test.*

**D4.2.1.1** The temperature of the Ambient Air ( $T_{amb}$ ) surrounding the UTSS

**D4.2.1.2** The power input to the UTSS, ( $kW_{UTSS}$ )

**D4.2.2** *Discharge Cycle Test and Discharge Periods of the Charge Cycle Test.*

**D4.2.2.1** The temperature of the Ambient Air ( $T_{amb}$ ) surrounding the UTSS

**D4.2.2.2** The power input to the UTSS, ( $kW_{UTSS}$ )

**D4.2.2.3** The refrigerant pressure ( $P_1$ ) at the inlet of the UTSS or the temperature of the Secondary Coolant leaving and entering the UTSS ( $T_5$  and  $T_6$ ), if applicable

**D4.2.2.4** Primary measurements of the temperatures and flow rate of the test apparatus heat transfer fluid at TS-3, TS-4, and FM-2, respectively

**D4.2.2.5** Confirming measurements of the temperatures and flow rate of the test apparatus heat transfer fluid at TS-1, TS-2, and FM-1, respectively

**D4.2.2.6** One measurement of the refractive index of any Secondary Coolant during the discharge cycle test and Discharge Periods of the charge cycle test

**D5** *Instruments.*

**D5.1** *General.* Instruments (or instrument systems) shall be selected to meet the requirements and accuracies specified in the following subsections.

**D5.1.1** Instrument calibrations shall be traceable to primary or secondary standards calibrated by the National Institute of Standards and Technology. The indicated corrections shall be applied to obtain the required accuracy. Instruments shall be recalibrated on a regular schedule appropriate for the respective instruments, and full calibration records shall be maintained.

**D5.1.2** All instruments shall be applied and used in accordance with the standards specified for that type of instrument and in a manner that ensures compliance with the specified accuracy.

**D5.2** *Temperature Measurements.* Temperature measurements shall be made in accordance with ANSI/ASHRAE Standard 41.1 with instruments having accuracies within the limits specified for the following measurements:

**D5.2.1** Individual refrigerant, water, and other heat transfer fluids, or air dry-bulb temperatures:  $\pm 0.10^\circ\text{F}$

**D5.2.2** Temperature differences in refrigerant and water within 2% of the numerical value of the difference being measured

**D5.3** *Pressure Measurements.* Pressure measurements shall be made in accordance with ANSI/ASHRAE Standard 41.3 and ASME PTC 19.2. The accuracy of instruments for measuring the pressure of fluids and the pressure differential across the Thermal Storage Device shall permit determination of the pressure or pressure differential within 2% of the numerical value of the quantity being measured.

**D5.4** *Electrical Measurements and Instruments.* Electric power measurements shall be made at a location such that the instrumentation can accurately measure the total power input to the device. The instrumentation used shall measure true rms power within 1% of the quantity measured. Test sites that utilize power-altering equipment may

require appropriate isolation and precautions between the measurement point and the load device to ensure that accurate power measurements are obtained.

**D5.5** *Flow Measurements.* Flow rates of heat transfer fluids (including refrigerants) shall be measured in accordance with ASHRAE Standard 41.8 and the appropriate apparatus standard listed below for the instrument being used. Instruments shall have accuracies within 1% of the quantity measured. The instruments that may be used to measure the flow of heat transfer fluids include the following:

Calorimeters	ANSI/ASHRAE 41.9
Coriolis Meters	ASME MFC-11M
Electromagnetic meters	ASME MFC-16
Flow Nozzles	ASME MFC-3M
Orifices	ASME MFC-3M
Turbine Meters	ASME MFC-4M
Ultrasonic Meters	ASME MFC-5M
Venturi Meters	ASME MFC-3M
Vortex Meters	ASME MFC-6M

**D5.6** *Time Measurements.* Time measurements shall be made with instruments having accuracies of  $\pm 0.5\%$  of the elapsed time measured. This accuracy will include any uncertainty errors associated with starting and stopping the instrument.

**D5.7** *Physical and Thermodynamic Properties.* The physical and thermodynamic properties of fluids shall be determined from the following sources:

**D5.7.1** The heat transfer and thermodynamic properties of water shall be taken from the *ASHRAE Handbook Fundamentals*.

**D5.7.2** The heat transfer and thermodynamic properties of Secondary Coolants shall be taken from the *ASHRAE Handbook Fundamentals*, based on the refractive index measurements taken during the test(s).

**D5.7.2.1** Refractive index measurements shall be converted to concentration (in percent by volume) of the heat transfer fluid using standard conversion tables.

**D5.7.2.2** The properties shall be interpolated from data published in the *ASHRAE Handbook Fundamentals* at the concentration corresponding to the measured refractive index and a temperature representative of the fluid at the point of interest.

**D5.7.3** The physical and thermodynamic properties of refrigerants shall be taken from ASHRAE *Thermodynamic Properties of Refrigerants*. For refrigerants not listed in this source, NIST *Reference Fluid Thermodynamic and Transport Properties* or publications distributed by refrigerant manufacturers may be used. In all cases, the source from which the data are taken shall be stated in the test report.

**D6** *Apparatus.*

**D6.1** *Configuration.* The test apparatus shall be comprised of two distinct parts, an outdoor condition test room and a discharge cycle test apparatus.

**D6.1.1** *Outdoor Condition Test Room.*

**D6.1.1.1** The outdoor condition test room for the charge and discharge cycle tests, as a minimum, shall conform to the requirements set forth in Section 8 of ANSI/ASHRAE Standard 37.

**D6.1.1.2** The outdoor inlet air dry-bulb temperature shall be measured in accordance with the requirements set forth in Section 8 of ANSI/ASHRAE Standard 37.

**D6.1.2** *Discharge Cycle Test Apparatus.*

**D6.1.2.1** The discharge cycle test apparatus may be of open or closed loop design and, as a minimum, shall consist of a heat source, a heat exchanger, circulating pumps, a mixing valve, interconnecting piping, and instrumentation, as shown in Figure D1.

**D6.1.2.2** The piping for the heat transfer fluids shall be sufficiently insulated to minimize the heat losses that would otherwise affect the validity of the primary and confirming capacity measurements.

**D7** *Test Procedure.***D7.1** *Preparation for Test.*

**D7.1.1** The UTSS shall be installed in the outdoor condition test room and connected to the discharge cycle test apparatus in accordance with the manufacturer's installation instructions.

**D7.1.2** After installation and before testing, the unit shall be cycled (charged and discharged) as recommended by the manufacturer.

**D7.2** *Operational Limits and Test Requirements.***D7.2.1** *Charge Cycle Test.*

**D7.2.1.1** The ambient condition for the Charge Period shall be determined prior to the start of the test and maintained per ANSI/ASHRAE Standard 37 over the duration of the test.

**D7.2.1.2** Charge Periods shall be terminated by the UTSS controller based on the manufacturer's definition of the fully charged condition.

**D7.2.1.3** The profile of the load imposed on the UTSS during the Discharge Period shall be determined prior to the start of the test. The load imposed during each Period shall be within 10% of the specified value.

**D7.2.1.4** The total heat added to the UTSS during the Discharge Period ( $Q_M$ ) shall be determined using the flow rate and temperatures of the discharge apparatus heat transfer fluid as measured at FM-2 and the temperature sensors, TS-3 and TS-4.

**D7.2.1.5** The confirming test of the Discharge Period test shall consist of measuring and recording the flow rate and temperatures of the discharge apparatus heat transfer fluid at flow meter FM-1 and temperature sensors, TS-1 and TS-2. These values shall be used to calculate the total heat added to the Thermal Storage Device over the duration of the Discharge Period. For the test to be valid, the result of this confirming test shall agree within 3% of the primary test value.

**D7.2.2** *Discharge Cycle Test.*

**D7.2.2.1** The ambient condition for the Charge Period shall be determined prior to the start of the test and maintained per ANSI/ASHRAE Standard 37 over the duration of the test.

**D7.2.2.2** The Charge Period shall be terminated by the UTSS controller based on the manufacturer's definition of the fully charged condition.

**D7.2.2.3** The duration of the Discharge Period and the profile of the load imposed on the UTSS shall be determined prior to the test. The duration of the Discharge Period test shall be within 10% of the specified duration and the load imposed during each Period shall be within 10% of the specified value.

**D7.2.2.4** The total heat added to the UTSS during the Discharge Period ( $Q_D$ ) shall be determined using the flow rate and temperatures of the discharge apparatus heat transfer fluid as measured at FM-2 and the temperature sensors, TS-3 and TS-4.

**D7.2.2.5** The confirming test of the discharge period test shall consist of measuring and recording the flow rate and temperatures of the discharge apparatus heat transfer fluid at flow meter FM-1 and temperature sensors, TS-1 and TS-2. These values shall be used to calculate the total heat added to the storage device over the duration of the Discharge Period. For the test to be valid, the result of this confirming test shall agree within 3% of the primary test value.

**D7.3** *Test Sequence.* A full test shall consist of the charge cycle test and discharge cycle test.

**D7.3.1** *Charge Cycle Test.*

**D7.3.1.1** *Initial UTSS Condition.* The UTSS shall be brought to the fully discharged, steady state condition as defined in Section D4.1.1.2.1.

**D7.3.1.2** *Outdoor Room Condition.* The outdoor room shall be brought to the test condition and maintained in accordance with the requirements set forth in section 8 of ANSI/ASHRAE Standard 37.

**D7.3.1.3** *Charge Period.* When the outdoor condition has been achieved, the UTSS charge mode shall be initiated. The charge mode shall be terminated by the UTSS controller based on the manufacturer's definition of the fully charged condition.

**D7.3.1.4** *Changeover Period.* Immediately after the Charge Period, with the UTSS fully charged, prepare the discharge cycle test apparatus by activating the heat source and pumps and adjusting the load to the heater to set the load for the Discharge Period.

**D7.3.1.5** *Discharge Period.* The Discharge Period begins when the UTSS discharge mode is activated. The Discharge Period ends when the UTSS reaches the fully discharged, steady state condition as defined in Section D4.1.1.2.1.

**D7.3.1.6** *Remaining Test Conditions.* The charge cycle test sequence shall be repeated for the remaining test conditions specified in Table 4.

**D7.3.2** *Discharge Cycle Test.*

**D7.3.2.1** *Initial UTSS Condition.* The UTSS shall be brought to the fully discharged, steady state condition as defined in Section D4.1.1.2.1.

**D7.3.2.2** *Outdoor Room Condition.* The outdoor room shall be brought to the test condition and maintained in accordance with the requirements set forth in section 8 of ANSI/ASHRAE Standard 37.

**D7.3.2.3** *Charge Period.* When the outdoor condition has been achieved, the UTSS charge mode shall be initiated. The charge mode shall be terminated by the UTSS controller based on the manufacturer's definition of the fully charged condition.

**D7.3.2.4** *Changeover Period.* Immediately after the Charge Period, with the UTSS fully charged, prepare the discharge cycle test apparatus by activating the heat source and pumps and adjusting the load to the heater to set the load for the Discharge Period.

**D7.3.2.5** *Discharge Period.* The Discharge Period begins when the UTSS discharge mode is activated. The Discharge Period ends when the Net Usable Storage Capacity ( $Q_D$ ) claimed for the device has been removed, at which point the UTSS is deactivated.

**D8** *Data to be Recorded.*

**D8.1** *Test Data.* The following test data shall be measured and recorded at evenly spaced Intervals not exceeding 5 minutes in duration over the full duration of each charge cycle and discharge cycle test.

**D8.1.1** *Charge Cycle Test.*

- D8.1.1.1** Temperature of the Ambient Air,  $T_{amb}$ , °F
- D8.1.1.2** Power input to the UTSS, kW
- D8.1.1.3** Time the test cycle was initiated and completed

**D8.1.2** *Discharge Cycle Test and Discharge Periods of the Charge Cycle Test (Figure D1).*

- D8.1.2.1** Temperature of the Ambient Air,  $T_{amb}$ , °F
- D8.1.2.2** Power input to the UTSS, kW
- D8.1.2.3** Time the test cycle was initiated and completed
- D8.1.2.4** Pressure of the refrigerant at location PS-1, psi
- D8.1.2.5** Temperature of the Secondary Coolant leaving and entering the UTSS at locations TS-5 and TS-6, °F (if applicable)
- D8.1.2.6** Temperature of the discharge test apparatus heat transfer fluid at locations TS-1, TS-2, TS-3, and TS-4, °F
- D8.1.2.7** Flow rate of the discharge test apparatus heat transfer fluid at locations FM-1 and FM-2, gpm or lbs/min
- D8.1.2.8** The refractive index of any Secondary Coolant used

**D8.2** *Data of Record.* The following data of record shall be taken and included in the test report:

- D8.2.1** Date, place and time of test
- D8.2.2** Names of test supervisors, technicians and witnessing personnel

**D8.3** *UTSS Unit Data.* The following product data shall be recorded and included in the test report:

- D8.3.1** Manufacturer's name and address
- D8.3.2** Model number, serial number, and all nameplate data of the UTSS
- D8.3.3** Manufacturer's Net Usable Storage Capacity, ton-hour
- D8.3.4** Storage medium
- D8.3.5** Specifics on heat transfer fluid(s) used to charge and discharge the UTSS, including:
  - D8.3.5.1** Name of the manufacturer
  - D8.3.5.2** Name/description of the heat transfer fluids
  - D8.3.5.3** Refractive index of glycol based Secondary Coolants
  - D8.3.5.4** Density of Secondary Coolants at 60°F, lb/ft<sup>3</sup>
  - D8.3.5.5** Specific heat of Secondary Coolants at 60°F, Btu/lb · °F
- D8.3.6** Overall Dimensions of the UTSS, in
- D8.3.7** Materials of construction of heat exchanger and/or storage vessel
- D8.3.8** Maximum operating pressure of the heat exchanger and/or storage vessel, psi
- D8.3.9** Maximum operating temperature of the heat exchanger and/or storage vessel, °F

**D9** *Calculation of Results.*

**D9.1** *Nomenclature, Symbols, and Subscripts.*

Symbols:

- $c_p$  = Specific heat at constant pressure, Btu/lb · °F
- $h_{source}$  = The enthalpy of the air being used to agitate the storage media in a Thermal Storage Device, at the source temperature and humidity, Btu/lb moist air

- $h_{sat}$  = The enthalpy of saturated air at the temperature of the storage media in a Thermal Storage Device, Btu/lb moist air  
 $K_1$  = A constant as may be required to correct for units of measure  
 $kWh_{Ch}$  = Total power consumed per hour by the UTSS when in the charge mode, kW  
 $kW_{I_{UTSS}}$  = The measured electrical power input to the UTSS, kW  
 $\overline{kW_{I_{UTSS}}}$  = The average measured electrical power input to the UTSS during the Charge Period, kW  
 $\dot{m}_{air}$  = The mass flow rate of air used to agitate the storage media in a Thermal Storage Device, lb/hr  
 $n$  = The number of test readings taken during each Period comprising a test cycle  
 $p$  = The number of Periods comprising a test cycle  
 $P_{Ch\ paras}$  = The shaft power of a parasitic device operating during the charge cycle test, tons  
 $P_{D\ paras}$  = The shaft power of a parasitic device operating during the discharge cycle test, tons  
 $P_1$  = The refrigerant pressure at the UTSS return, as determined by PS-1 in Figure D1, psi  
 $\overline{P_1}$  = The average return pressure for one of the Periods ( $p$ ) (consisting of Intervals 1 through  $n$ ) comprising the Discharge Period, psi  
 $Q_{air}$  = The calculated heat input to a Thermal Storage Device from air used to agitate the storage media, ton-hour  
 $Q_{amb}$  = The calculated heat input to the Thermal Storage Device from the ambient over the duration of the charge cycle test and discharge cycle test, ton-hour  
 $Q_{Ch}$  = Total Charge Capacity, ton-hour  
 $Q_D$  = Net Useable Storage Capacity, ton-hour  
 $Q_{paras}$  = The calculated heat input to the Thermal Storage Device from parasitic devices operating during the charge cycle test and discharge cycle test, ton-hour  
 $Q_M$  = Measured Storage Capacity determined during a Discharge Period of a Charge Cycle Test, ton-hour  
 $q_{amb}$  = The rate of heat gain from the ambient into the Thermal Storage Device at a specified temperature difference between the ambient and thermal storage media, ton  
 $\overline{q_{Ch}}$  = Average Charge Rate, tons  
 $q_{D_p}$  = The average Discharge Rate for one of the Periods ( $p$ ) (consisting of Intervals 1 through  $n$ ) comprising the discharge cycle test, tons  
 $T_{amb}$  = The temperature of the Ambient Air surrounding the Thermal Storage Device, °F  
 $\Delta T_{des}$  = The design temperature difference between the ambient and the storage media for which the value of the heat gain rate ( $q_{amb}$ ) is valid, °F  
 $\overline{T_n}$  = Temperature measured at the temperature sensor with the same numeric designation, i.e. TS-n, °F  
 $\overline{T_5}$  = Time weighted average outlet temperature, °F  
 $T_{SRT}$  = Time weighted average Saturated Return Temperature (SRT), °F  
 $T_{sm}$  = The temperature of the storage media in the Thermal Storage Device, °F  
 $t_{ChI}$  = Time at start of Charge Period  
 $t_{ChF}$  = Time at finish of Charge Period  
 $t_{DI}$  = Time at start of Discharge Period  
 $t_{DF}$  = Time at finish of Discharge Period  
 $\tau_{Ch}$  = Duration of the charge cycle test, h  
 $\tau_{Ch\ paras}$  = Total Period of operation of a parasitic device during the charge cycle test, h

- $\tau_D$  = Duration of the discharge cycle test, h  
 $\tau_{D \text{ paras}}$  = Total Period of operation of a parasitic device during the discharge cycle test, h  
 $W_{DFM-n}$  = Mass flow rate of the discharge apparatus heat transfer fluid used to discharge the UTSS as determined from flow meter FM-1 or flow meter FM-2 in Figure D1, lb/min  
 $W_{FM-2}$  = The mass flow rate of the heat transfer fluid measured at the flow meter with the same numeric designation, ie. FM-n, lb/min

Subscripts:

- Ch = Designates the value pertaining to a Charge Cycle  
D = Designates the value pertaining to Discharge Cycle  
paras = Designates the value pertaining to a parasitic device such as an air pump  
primary = Designates primary test  
confirm = Designates confirming test

**D9.2 Averaging.** The test readings of temperature, flow rate, pressure, etc. taken at each of the Intervals comprising a Period of the test cycle shall be averaged and used as the value for that Period.

**D9.3 Charge Cycle Test Calculations.** The calculations of this section along with the data obtained during the charge cycle test shall be used to determine the average power input and average Charge Rate for the UTSS.

**D9.3.1 Average Power Input** ( $\overline{kW}_{UTSS}$ ). The average power input to the UTSS during the Charge Period is the total power consumed per hour by the UTSS when in the charge mode.

$$\overline{kW}_{UTSS} = \left( \frac{kWh_{Ch}}{\tau_{Ch}} \right) \quad D1$$

**D9.3.2 Average Charge Rate.** The average Charge Rate over the duration of the Charge Cycle shall be calculated as:

$$\overline{q}_{Ch} = \left( \frac{Q_{Ch}}{\tau_{Ch}} \right) \quad D2$$

Where:

$$Q_{Ch} = Q_M + Q_{amb} + Q_{paras}$$

**D9.3.3 Measured Storage Capacity.** The Storage Capacity ( $Q_M$ ) is equal to the heat absorbed by the UTSS during the Discharge Period. For the primary test, it is calculated as:

$$Q_M = Q_{M \text{ primary}} = (K_1) \int_{t_{D1}}^{t_{DF}} W_{DFM-2} c_p (T_3 - T_4) dt \quad D3$$

and for the confirming test:

$$Q_{M \text{ confirm}} = (K_1) \int_{t_{D1}}^{t_{DF}} W_{DFM-1} c_p (T_2 - T_1) dt \quad D4$$

For a valid test, the following relationship shall hold true:

$$\left| \frac{Q_{M \text{ confirm}}}{Q_{M \text{ primary}}} - 1 \right| \leq 0.03 \quad D5$$



**D9.3.4 Average Discharge Rate.** Determine the average Discharge Rate for each Period (p) (consisting of Intervals 1 through n) comprising the Discharge Period as:

$$\overline{q_{Dp}} = (K_1) \left( \frac{1}{n} \right) \sum_{i=1}^n W_{FM-2n} c_p (T_{3n} - T_{4n}) \quad D6$$

**D9.3.5 Parasitic Heat Gain.** The parasitic heat gain into the UTSS during the Charge Period and the Discharge Period ( $Q_{paras}$ ) is determined as:

$$Q_{paras} = (K_1) \left[ (\tau_{Ch paras}) (P_{Ch paras}) + (\tau_{D paras}) (P_{D paras}) \right] \quad D7$$

Also, if the parasitic auxiliary is an air pump used for agitation of the storage media, the parasitic heat gain shall include the heat input to the UTSS as the air is cooled from its source temperature to the temperature of the storage media:

$$Q_{air} = (K_1) (\dot{m}_{air}) (h_{source} - h_{sat}) \quad D8$$

**D9.3.6 Ambient Heat Gain.** The ambient heat gain into the UTSS during the Charge Period and Discharge Period ( $Q_{amb}$ ) is determined as:

$$Q_{amb} = (K_1) (\tau_{Ch} + \tau_{D}) (q_{amb}) \left( \frac{T_{amb} - T_{sm}}{\Delta T_{des}} \right) \quad D9$$

**D9.4 Discharge Cycle Test Calculations.** The calculations of this section along with the data obtained during the discharge cycle test shall be used to determine the Net Usable Storage Capacity for the UTSS.

**D9.4.1 Net Usable Storage Capacity.** The Net Usable Storage Capacity ( $Q_D$ ) is equal to the heat absorbed by the UTSS during the Discharge Period. For the primary test, it is calculated as:

$$Q_D = Q_{D primary} = (K_1) \int_{t_{D1}}^{t_{DF}} W_{DFM-2} c_p (T_3 - T_4) dt \quad D10$$

and for the confirming test:

$$Q_{D confirm} = (K_1) \int_{t_{D1}}^{t_{DF}} W_{DFM-1} c_p (T_2 - T_1) dt \quad D11$$

For a valid test, the following relationship shall hold true:

$$\left| \frac{Q_{D confirm}}{Q_{D primary}} - 1 \right| \leq 0.03 \quad D12$$

**D9.4.2 Average Discharge Rate.** Determine the average Discharge Rate for each Period (p) (consisting of Intervals 1 through n) comprising the Discharge Period as:

$$\overline{q_{Dp}} = (K_1) \left( \frac{1}{n} \right) \sum_{i=1}^n W_{FM-2n} c_p (T_{3n} - T_{4n}) \quad D13$$

**D9.5 Initial Charge Time.** The initial charge time shall be equal to the duration of the Charge Period measured during the charge cycle test at the conditions specified in Table 4. These data are required since the time required to initially charge the device may be longer than the recharge because in some storage devices some residual cooling shall be left in the device in order for it to perform properly.

Therefore, it is important to know the time required to initially charge the device or to recharge it, if for some reason the device is totally discharged when in normal operation.

**D10 Test Evaluation.**

**D10.1 Procedure.** The performance of the UTSS shall be evaluated by comparing the measured test data averaged over each Period comprising the test cycle to the performance predicted by the manufacturer's rating methodology for the corresponding Period.

**D10.1.1 Charge Cycle Test.** To determine the power input of the UTSS as predicted by the manufacturer's rating methodology, use the average ambient air temperature during the Charge Period as the input.

For the charge rating to be verified, the average measured  $kW_{UTSS}$  for the charge period shall be no greater than 5% above the values predicted by the manufacturer's rating methodology for the corresponding rating condition.

**D10.1.2 Discharge Cycle Test.** To determine the temperatures of the Discharge Fluid entering and leaving the UTSS for each Period, as predicted by the manufacturer's rating methodology, use the average Discharge Rate for each Period of the discharge cycle test (see Equation D9.4.2) as the input for each Period.

For the discharge rating to be verified, the measured fluid temperatures averaged over each Period of the discharge cycle shall be no greater than 0.5°F above those values predicted by the rating methodology for that Period.

**D11 Test Report.**

**D11.1 General Information.** A written test report shall be prepared and distributed to the parties involved in the test. Included in the introduction to the report shall be:

- D11.1** The name and address of the test facility
- D11.2** The name(s), title(s) and affiliation(s) of those persons conducting the test, witnessing the test, and preparing the test report. Also included shall be the name, title, and signature of the person(s) accepting responsibility for the content of the report
- D11.3** The date the test was conducted and the date of the report
- D11.4** The name and address of the client
- D11.5** The method by which the test unit was selected (i.e. random selection) and its condition

**D11.2 Test Unit Description.** The report shall include a full description of the test unit, using as a minimum the data specified in Section D8.3.

**D11.3 Test System Description.** A description of the test facility and primary apparatus shall be included in the report, complete with a system diagram showing the interconnecting piping and the locations of the principle components and instrumentation. Also included in this section shall be the specifics of the heat transfer fluid(s) employed for the test, including the basic data specified in Section D8.3.5.

**D11.4 Test Unit Data.** The report shall include a summary of the unit performance with the following overall data and calculation results:

- D11.4.1** The Net Usable Storage Capacity,  $Q_D$ , ton-hour
- D11.4.2** The type(s) of heat transfer fluid(s) used in the Charge Cycle and Discharge Cycle
- D11.4.3** The duration of the charge cycle, h
- D11.4.4** The average Charge Rate ( $\overline{q_{ch}}$ ) of the charge cycle test, tons

**D11.4.5** The average measured electrical power input,  $\overline{kWI_{UTSS}}$ , for each Charge Period of the charge cycle tests, kW

**D11.4.6** The total capacity ( $Q_{Ch}$ ) for each Charge Period of the charge cycle test, ton-hour

**D11.4.7** The duration of the Discharge Period of the discharge cycle test, h

**D11.4.8** The average Discharge Rate ( $\overline{q_D}$ ) for the Discharge Period of the discharge cycle test, tons

**D11.4.9** The maximum temperature attained by the heat transfer fluid leaving the storage device during the Discharge Period of the discharge cycle test, °F

**D11.4.10** Table D1 for the charge cycle test comparing the measured UTSS power input, averaged over the Charge Period, to the UTSS power input predicted by the rating methodology for the corresponding test condition, kW

**D11.4.11** Table D2 for the discharge cycle test, comparing the measured temperatures of the heat transfer fluid as it enters and leaves the UTSS, averaged over each Period comprising the test cycle, to the temperatures predicted by the rating methodology for the corresponding Period. For a UTSS using a refrigerant as the Discharge Fluid, use the  $T_{SRT}$ , °F

**D11.4.12** A copy of the performance of the UTSS as predicted by the manufacturer's rating methodology, when using the ambient temperature of the charge cycle test and the load profile imposed during the discharge cycle test as input.

**D11.5** *Calculation Summary.* The report shall include a summary sheet showing the results of all calculations for each reading along with an example of the complete calculations for one set of readings. Also included in this section shall be a statement of compliance with or deviation from the provisions in this standard.

**D11.6** *Raw Test Data.* The raw test data shall be compiled and recorded in a legible form and included in the report. Hard copy shall be included even if data are also stored on electronic media.

**D11.7** *Instrument Summary.* The report shall include a tabulation of all instruments used in the test including the serial number, latest calibration date, and the means by which the instrument was calibrated.

Outdoor Ambient Rating Condition, °F	Actual Average Outdoor Ambient Temperature, °F	Charge Period Start Time	Charge Period End Time	Charge Period Duration, h	Measured Average Power ( $\overline{kWI_{UTSS}}$ ), kW	Predicted Average Power ( $\overline{kWI_{UTSS}}$ ), kW	Difference
55°							
65°							
75°							
85°							
95°							

Period	Discharge Rate (q), tons	Temperature of Heat Transfer Fluid Entering Storage Device, °F			Temperature of Heat Transfer Fluid Leaving Storage Device, °F		
		Measured	Predicted	Difference	Measured	Predicted	Difference
#1							
#2							
#...							
#p							

## APPENDIX E. METHOD OF FIELD TESTING FOR RATING THERMAL STORAGE DEVICES – NORMATIVE

**E1** *Purpose.* The purpose of this appendix is to prescribe a method of testing Thermal Storage Devices not readily tested in a laboratory to establish their performance at a specific set of conditions.

**E1.1** *Intent.* The procedures set forth in this appendix are intended for use in situations where adequate instrumentation and control can be provided.

**E1.2** *Exemptions.* This procedure is not intended for devices which may be readily tested in a laboratory environment.

**E2** *Scope.* This procedure applies only to sensible (chilled water) and latent (encapsulated ice, Phase Change Material, and ice on coil) Thermal Storage Devices as defined in Section 4 of the standard and, as mentioned in Appendix D. (Refer to other appendices for methods of testing equipment in the laboratory or for other equipment classifications)

**E3** *Definitions.* Definitions for this appendix are identical with those in Section 3 of this standard.

**E4** *Method of Testing.*

**E4.1** *Test Method.* The test will determine the Net Usable Storage Capacity of the device at specified operating conditions by measuring the net heat absorbed by the storage device during the discharge cycle test and the net heat removed from the device during the charge cycle test.

**E4.1.1** The heat loads, flow rates and temperatures as specified for the selected rating for the charge cycle test and discharge cycle test shall be determined prior to the start of the test.

**E4.1.2** Identification of temperature and flow instrumentation in this section and throughout subsequent sections of this appendix are for reference only and apply to the specific test configuration in Figure E1. Other test instrumentation which accomplishes the same purpose and achieves the same accuracy is acceptable and references to instrumentation may be substituted where appropriate (see Section E6.1).

**E4.1.3** The initial charge cycle test shall determine the elapsed time required to bring the storage device to its fully charged condition and the minimum temperature of the heat transfer fluid attained during the cycle.

**E4.1.3.1** At the beginning of the initial charge cycle test, the Thermal Storage Device shall be in a fully discharged, steady state condition as defined in Section E7.3.1.

**E4.1.3.2** The initial charge cycle test shall determine the time weighted average inlet temperature ( $\overline{T_1}$ ), the time weighted average outlet temperature ( $\overline{T_2}$ ), the minimum inlet temperature at ( $T_{1min}$ ), the average Charge Rate ( $\overline{q_{Ch}}$ ) and the total heat removed ( $Q_{IC}$ , Nominal Storage Capacity) to bring the storage device to its fully charged condition.

**E4.1.3.3** The initial charge cycle test shall be complete when the storage device has reached the fully charged condition as defined by the manufacturer's published criteria.

**E4.1.4** The discharge cycle test shall verify that the temperatures delivered for a specific imposed load agree within the allowable tolerance, Period by Period, with those predicted by the manufacturer's rating methodology when using the test load profile as input.

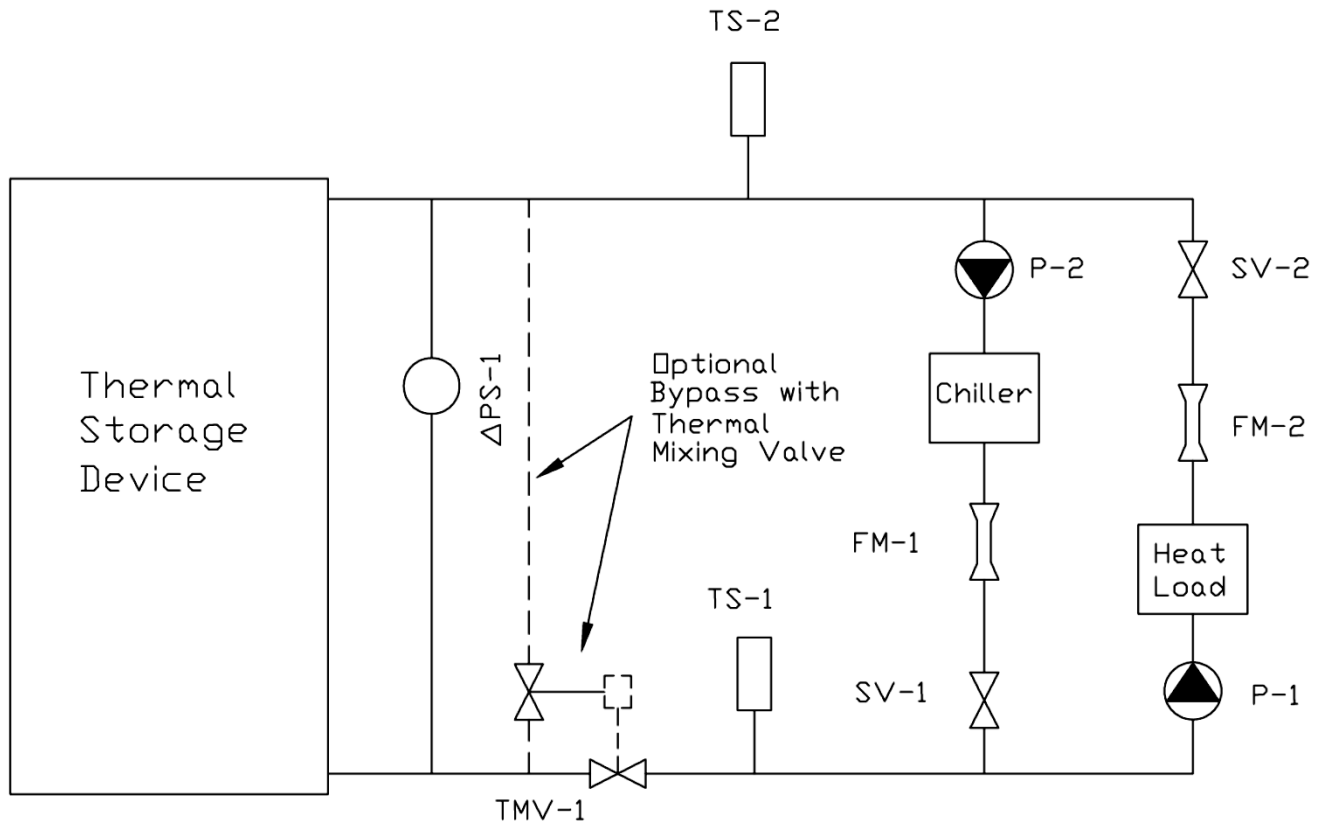

**Figure E1. Thermal Storage Device Test Apparatus**

Where:

- |                                    |   |
|------------------------------------|---|
| ΔPS = Differential Pressure Sensor | SV = Shut-Off Valve                     |
| FM = Flow meter                    | TMV = Temperature Actuated Mixing Valve |
| P = Pump                           | TS = Temperature Sensor                 |

**E4.1.4.1** At the beginning of the discharge cycle test, the storage device shall be in a fully charged condition in accordance with the manufacturer's published criteria.

**E4.1.4.2** The discharge cycle test shall be complete when the Net Usable Storage Capacity ( $Q_D$ ) claimed for the imposed load profile has been removed from the device. As discussed in Section E9.11, some residual cooling capacity may still remain in the Thermal Storage Device at this point since the duration of the discharge cycle test is solely a function of the Net Usable Storage Capacity, not the state of charge of the Thermal Storage Device.

**E4.1.5** The charge cycle test shall verify that the temperatures of the heat transfer fluid required to recharge the device agree, Period by Period, with those predicted by the manufacturer's rating methodology when using as input the chiller capacity actually delivered during the test.

**E4.1.5.1** At the beginning of the charge cycle test, the storage device shall be in the state of discharge reached at the end of the discharge cycle test.

**E4.1.5.2** The charge cycle test shall determine the time weighted average inlet temperature ( $\overline{T_1}$ ), the time weighted average outlet temperature ( $\overline{T_2}$ ), the minimum inlet temperature ( $T_{1min}$ ), the average charging rate ( $\overline{q_{Ch}}$ ) and the total heat removed ( $Q_{Ch}$ ) to recharge the storage device to its original condition at the initiation of the discharge cycle test.

**E4.1.5.3** The charge cycle test shall be complete when the storage device has been returned to its initial fully charged condition as defined in Section E4.1.3.3.

**E4.1.6** The following data shall be measured and recorded during the above described initial charge cycle test, discharge cycle test and charge cycle test:

**E4.1.6.1** The flow rate of the charge cycle test fluid (water or Secondary Coolant) flowing through the storage device as measured at FM-1 (Figure E1).

**E4.1.6.2** The flow rate of the discharge cycle test fluid (water or Secondary Coolant) flowing through the storage device as measured at FM-2, if applicable (Figure E1).

**E4.1.6.3** The temperature difference in the discharge cycle test fluid (Secondary Coolant or water) as it enters and leaves the storage device (TS-1 and TS-2).

**E4.1.6.4** The pressure drop imparted to the charging and discharging fluid measured across the Thermal Storage Device ( $\Delta PS-1$ ).

**E4.1.6.5** The power input to any auxiliary equipment such as air pumps, agitators, etc.

**E4.1.6.6** The refractive index of any Secondary Coolants used during the discharge cycle test and/or charge cycle test.

**E5** *Instruments.*

**E5.1** *General.*

**E5.1.1** Instruments (or instrument systems) shall be selected to meet the specified accuracies given in the following subsections.

**E5.1.2** Instrument calibrations shall be traceable to primary or secondary standards calibrated by the National Institute of Standards and Technology. The indicated corrections shall be applied to obtain the required accuracy. Instruments shall be calibrated on a regular schedule appropriate for the respective instruments, and full calibration records shall be maintained.

**E5.1.3** Instruments shall be used in accordance with the standards specified for that type of instrument and in a manner that ensures compliance with the specified accuracy.

**E5.1.4** When testing systems installed after the promulgation of this standard, all measurements shall be made using two instruments at each measurement location. The average of the two instrument readings shall be used as the measurement.

**E5.1.4.1** When testing systems installed before the promulgation of this standard where provision has not been made for dual instrumentation, single instruments may be employed at each measurement location and the instrument calibration shall be verified before and after the test series. It is also recommended that temperature sensors TS-1 and TS-2 be interchanged mid-way through each test run to nullify the effect of sensor tolerances.

**E5.2 Temperature Measurements.** Temperature measurements shall be made in accordance with ANSI/ASHRAE Standard 41.1 with instruments having accuracies within the limits specified for the following measurements:

**E5.2.1** Individual temperatures of water and other heat transfer fluids, or air dry-bulb temperatures:  $\pm 0.10^{\circ}\text{F}$

**E5.2.2** Temperature differences in heat transfer fluids within 5% of the numerical value of the difference being measured, not to exceed  $0.20^{\circ}\text{F}$

**E5.3 Pressure Measurements.** Pressure measurements shall be made in accordance with ANSI/ASHRAE Standard 41.3 and ASME PTC 19.2. The accuracy of instruments for measuring the pressure of fluids and the pressure differential across the Thermal Storage Device shall permit determination of the pressure or pressure differential within  $\pm 0.5$  psi of the numerical value of the quantity being measured.

**E5.4 Electrical Measurements and Instruments.** Electric power measurements shall be made at a location such that the instrumentation can accurately measure the total power input. The instrumentation used shall measure true rms power within 1% of the quantity measured. Test sites that utilize power-altering equipment may require appropriate isolation and precautions between the measurement point and the load device to ensure that accurate power measurements are obtained.

**E5.5 Flow Measurements.** Flow rates of water or heat transfer fluids (including refrigerants) shall be measured in accordance with ASHRAE Standard 41.8 and the standard listed below for the instrument being used. Instruments shall have accuracies within 2% of the quantity measured. The instruments that may be used to measure the flow of water or heat transfer fluids include the following:

Coriolis Meters	ASME MFC-11M
Electromagnetic Meters	ASME MFC-16
Flow Nozzles	ASME MFC-3M
Orifices	ASME MFC-3M
Turbine Meters	ASME MFC-4M
Ultrasonic Meters	ASME MFC-5M
Venturi Meters	ASME MFC-3M
Vortex Meters	ASME MFC-6M

**E5.6 Time Measurements.** Time measurements shall be made with instruments having accuracies of  $\pm 1.0\%$  of the elapsed time measured. This accuracy will include any uncertainty errors associated with starting and stopping the instrument.

**E.5.7 Physical and Thermodynamic Properties.** The physical and thermodynamic properties of fluids shall be determined from the following sources:

**E5.7.1** The heat transfer and thermodynamic properties of water shall be taken from the *ASHRAE Handbook Fundamentals*.

**E5.7.2** The heat transfer and thermodynamic properties of Secondary Coolants shall be taken from the *ASHRAE Handbook Fundamentals*, based on the refractive index measurements taken during the test(s).

**E5.7.2.1** Refractive index measurements shall be converted to concentration (in percent by volume) of the heat transfer fluid using standard conversion tables.

**E5.7.2.2** The properties shall be interpolated from the data published in the *ASHRAE Handbook Fundamentals* at the concentration corresponding to the measured refractive index and a temperature representative of the fluid at the point of interest.

**E6** *Test System Description.*

**E6.1 Configuration.** The test system shall be comprised of the equipment shown in Figure E1 with the position of the Thermal Storage Device relative to the balance of the system as shown. The system may be of open or closed loop design and shall be capable of achieving the heat loads and flow rates specified in Section E7.2. The system diagram in Figure E1 and the relative locations of the components and instruments are for reference only and define a system in which the direction of flow through the storage device is reversed for charge cycle test and discharge cycle test cycles. Fluid flow in a single direction shall also be acceptable. Relevant instrument locations and references in this appendix shall be modified appropriately. This test shall also be valid for systems in which a single pump set and single flow meter are installed in conjunction with control valves to alternate between charge and discharge modes.

**E6.2 Piping for Heat Transfer Fluid.** The piping to which the differential pressure measuring device ( $\Delta$ PS-1) is connected shall be of the same diameter on both the inlet and the outlet of the Thermal Storage Device.

**E6.3 Insulation.** All piping, including the piping between temperature measuring points TS-1 and TS-2 shall be sufficiently insulated to minimize the heat losses that would otherwise affect the validity of the capacity measurements.

**E7** *Test Procedure.***E7.1** *Preparation for Test.*

**E7.1.1** The storage device shall be installed in accordance with the manufacturer's installation instructions.

**E7.1.2** After installation and before testing, the unit shall be cycled (charged and discharged) as recommended by the manufacturer.

**E7.2** *Operational Limits and Test Requirements.*

**E7.2.1** The duration and load profile of the charge cycle test and discharge cycle test shall be determined prior to the start of the test.

**E7.2.2** Pumps which are operational at the beginning of any charge cycle test shall remain operational and shall operate at the same speed over the duration of the entire test. This condition shall be considered to have been achieved if the measured flow rate varies by less than  $\pm 10\%$  over the duration of any given initial charge or charge cycle test.

**E7.2.3** The rate of heat removal from the Thermal Storage Device during the initial charge cycle test and the charge cycle test shall be set by the operation of the chiller(s), the value of which shall be within 10% of the rate specified for each Period. The chiller leaving fluid temperature set point shall be that specified by the manufacturer of the Thermal Storage Device.

**E7.2.4** During an initial charge cycle test or a charge cycle test, the average rate of heat removal will be determined by the heat balance between the chiller(s) and the storage device. All other sources of heat gain or heat loss shall be isolated from the chiller(s) and storage device. The capacity of the chiller shall not be mechanically altered during either test. For the tests to be valid, the average heat removal rate of the initial charge cycle test shall be within 10% of the average heat removal rate of the charge cycle test.

**E7.2.5** The Discharge Rate over the duration of the discharge cycle test will follow the system cooling load; the value of which shall be within 10% of the rate specified for each Period.

**E7.2.6** The total heat removed from the storage device during the initial charge cycle test ( $Q_{IC}$ ) and the charge cycle test ( $Q_{Ch}$ ) and the total heat added to the storage device during the discharge cycle test ( $Q_D$ ) shall be determined using the flow rates of the heat transfer fluid as measured at FM-1 and/or FM-2 and the temperatures of the heat transfer fluid as measured at sensors TS-1 and TS-2. After correcting the calculated values for ambient and parasitic heat gains, the total heat input during the discharge cycle test shall be within 10% of the total heat removed during the charge cycle test.



**E7.3 Test Sequence.** A full test shall consist of an initial charge cycle test, a discharge cycle test, and a charge cycle test, conducted in the following sequence:

**E7.3.1 Initial Steady State Conditions.** With the Thermal Storage Device in the fully discharged condition, water or Secondary Coolant shall be circulated through the test loop and the storage device until the initial steady state conditions are established. Initial steady state conditions shall be considered achieved when the temperature measured at TS-1 is greater than or equal to 13°F above the phase change temperature for latent storage devices or at the design warm water inlet temperature as determined for sensible storage devices, and the temperatures at TS-1 and TS-2 are equal within the specified accuracies of the instruments.

**E7.3.2 Changeover Period I.** During this and all subsequent changeover Periods, secondary sources of heat (such as auxiliary heaters, agitation systems in the Thermal Storage Device, etc.) shall be turned off. During this first changeover Period, the pumps, flow rates and valves shall be adjusted for the initial charge cycle test. When all components are set, the chiller shall be turned on.

**E7.3.3 Initial Charge Cycle Test.** The initial charge cycle test shall be conducted at the capacity of the chiller installed on the system. The chiller(s) used for the initial charge cycle test shall be the same chiller(s) used for all subsequent charge cycle tests. The leaving fluid temperature from the chiller(s) shall be that specified by the thermal storage device manufacturer. The leaving fluid temperature set point shall be the same for the initial charge cycle test as the subsequent charge cycle tests. All other sources of heat gain or heat loss shall be isolated from the storage chiller(s) and storage device. During the initial charge cycle test, any agitation devices or other auxiliary equipment furnished with the device, shall be operated in accordance with the thermal storage manufacturer's published instructions. The initial charge cycle test shall end when the storage device is fully charged in accordance with the thermal storage manufacturer's published specifications.

**E7.3.4 Changeover Period II.** After the initial charge cycle test, with the storage device fully charged, pumps, auxiliary equipment and valves shall be set to allow initiation of the discharge cycle test. All other sources of heat gain or heat loss other than the discharge heat source (load) shall be isolated from the storage device.

**E7.3.5 Discharge Cycle Test.** The discharge cycle test begins when the pumps and heat source or the heat load are applied. During the discharge cycle test, any agitation devices normally furnished with the Thermal Storage Device shall be operated in accordance with the manufacturer's published instructions. The discharge test cycle ends when the Net Usable Storage Capacity ( $Q_D$ ) claimed for the device has been removed, at which point the heat source is deactivated.

**E7.3.6 Changeover Period III.** Upon completion of the discharge cycle test, flow through the storage device shall be stopped. During this Period, pump(s) and valves shall be adjusted to allow initiation of the charge cycle test. When all components are set, the pump(s) and chiller(s) shall be turned on.

**E7.3.7 Charge Test.** The charge cycle test shall begin by starting the pump(s) and chiller(s) and diverting full flow of water or secondary fluid through the storage device. The charge cycle test shall end when the storage device is fully charged as defined by the manufacturer's published instructions.

**E8 Data to be Recorded.**

**E8.1 Test Data.** The following test data shall be recorded over the full duration of each charge cycle test and discharge cycle test with a minimum of 50 readings at equally spaced Intervals required for a valid test cycle.

- E8.1.1** Temperature of heat transfer fluid at locations TS-1 and TS-2, °F
- E8.1.2** Temperature of the Ambient Air,  $T_{amb}$ , °F
- E8.1.3** Temperature of ambient soil surrounding buried tanks,  $T_{amb}$  °F
- E8.1.4** Flow rate of the heat transfer fluid at locations FM-1 and/or FM-2, gpm
- E8.1.5** Differential pressure of the heat transfer fluid across the Thermal Storage Device,  $\Delta PS-1$ , psi
- E8.1.6** Time the test cycle was initiated and completed

**E8.2 Test Data for Auxiliaries.** If liquid pumps or air pumps are required for the proper operation of the storage device, the following additional data shall be recorded at evenly spaced Intervals not exceeding 30 minutes in duration.

- E8.2.1** Power consumption of accessory pump or air compressor, kW
- E8.2.2** Temperature of supply liquid or air to any such accessories, °F
- E8.2.3** Flow rate of liquid, gpm, or air, cfm

**E8.3** *Record Data.* The following data of record shall be taken and included in the test report:

- E8.3.1** Date, place and time of test
- E8.3.2** Name of test supervisors and witnessing personnel
- E8.3.3** Specifics on heat transfer fluid including:
  - E8.3.1.1** Name of the manufacturer
  - E8.3.1.2** Name/description of the heat transfer fluids
  - E8.3.1.3** Refractive index of Secondary Coolants
  - E8.3.1.4** Density of Secondary Coolants at 60°C, lb/ft<sup>3</sup>
  - E8.3.1.5** Specific heat of Secondary Coolants at 60°C, Btu/lb · °F

**E8.4** *Thermal Storage Unit Data.* The following product data shall be recorded and included in the test report:

- E8.4.1** Manufacturer's name and address
- E8.4.2** Model number, serial number, and all nameplate data of the Thermal Storage Device
- E8.4.3** Manufacturer's Net Usable Storage Capacity, ton-hour
- E8.4.4** Storage medium
- E8.4.5** Overall dimensions of the Thermal Storage Device, in
- E8.4.6** Materials of construction of heat exchanger and/or storage vessel
- E8.4.7** Maximum operating pressure of the heat exchanger and/or storage vessel, psi
- E8.4.8** Maximum operating temperature of the heat exchanger and/or storage vessel, °F
- E8.4.9** Maximum allowable flow rate of heat transfer fluid(s), gpm
- E8.4.10** Minimum allowable flow rate of heat transfer fluid(s), gpm
- E8.4.11** Type, power requirement, and nameplate data of auxiliaries including agitation devices if employed

**E9** *Calculation of Results.*

**E9.1** *Nomenclature, Symbols and Subscripts.*

Symbols:

- $c_p$  = Specific heat at constant pressure, Btu/lb · °F
- $h_{\text{source}}$  = The enthalpy of the air being used to agitate the storage media in a Thermal Storage Device, at the source temperature and humidity, Btu/lb moist air
- $h_{\text{sat}}$  = The enthalpy of saturated air at the temperature of the storage media in a Thermal Storage Device, Btu/lb moist air
- $K_1$  = A constant as may be required to correct for units of measure
- $\dot{m}_{\text{air}}$  = The mass flow rate of air used to agitate the storage media in a Thermal Storage Device, lb/h
- $n$  = The number of tests taken during each Period or the number of Periods comprising a test cycle
- $p$  = The number of Periods (typically of one hour duration) comprising a test cycle
- $P_{\text{Ch paras}}$  = The shaft power of a parasitic device operating during the charge cycle test, tons
- $P_{\text{D paras}}$  = The shaft power of a parasitic device operating during the discharge cycle test, tons

$Q_{air}$	=	The calculated heat input to a Thermal Storage Device from air used to agitate the storage media, ton-hour
$Q_{amb}$	=	The calculated heat input to the Thermal Storage Device from the ambient over the duration of the charge cycle test and discharge cycle test, ton-hour
$Q_{Ch}$	=	Total charge capacity, ton-hour
$Q_D$	=	Net Usable Storage Capacity, ton-hour
$Q_{IC}$	=	Initial charge capacity, as determined from the initial charge cycle test, ton-hour
$Q_{paras}$	=	The calculated heat input to the Thermal Storage Device from parasitic devices operating during the charge cycle test and discharge cycle test, ton-hour
$q_{amb}$	=	The rate of heat gain from the ambient into the Thermal Storage Device at a specified temperature difference between the ambient and thermal storage media, tons
$\overline{q}_{Ch}$	=	The average Charge Rate over the duration of the charge cycle test, tons
$\overline{q}_{Ch_p}$	=	The average Charge Rate for one of the individual Periods (p) (consisting of Intervals l through n) comprising the charge cycle test, tons
$\overline{q}_{IC}$	=	The average Charge Rate over the duration of the initial charge cycle test, tons
$\overline{q}_{D_p}$	=	The average Discharge Rate for one of the individual time Periods (p) (consisting of Intervals l through n) comprising the discharge cycle test, tons
$T_{amb}$	=	The temperature of the Ambient Air surrounding the Thermal Storage Device, °F
$\Delta T_{des}$	=	The design temperature difference between the ambient and the storage media for which the value of the heat gain rate ( $q_{amb}$ ) is valid, °F
$T_{sm}$	=	The temperature of the storage media in the Thermal Storage Device, °F
$T_1$	=	Temperature measured at Sensor TS-1, °F
$T_{1m}$	=	Minimum inlet temperature at Sensor TS-1, °F
$\overline{T}_1$	=	Average time weighted inlet temperature
$T_2$	=	Temperature measured at Sensor TS-2, °F
$\overline{T}_2$	=	Average time weighted outlet temperature
$t_{ChI}$	=	Time at start of Charge Cycle
$t_{ChF}$	=	Time at finish of Charge Cycle
$t_{DI}$	=	Time at start of Discharge Cycle
$t_{DF}$	=	Time at finish of Discharge Cycle
$t_{IC1}$	=	Time at start of initial Charge Cycle
$t_{ICF}$	=	Time at finish of initial Charge Cycle
$\tau_{Ch}$	=	Duration of the charge cycle test, h
$\tau_{Ch\ paras}$	=	Total Period of operation of a parasitic device during the charge cycle test, h
$\tau_D$	=	Duration of the discharge cycle test, h
$\tau_{IC}$	=	Duration of the initial cycle test, h
$\tau_{D\ paras}$	=	Total Period of operation of a parasitic device during the discharge cycle test, h

- $W_{ChFM-1}$  = Flow rate of Charging Fluid as measured at flow meter FM-1, gpm  
 $W_{DFM-2}$  = Flow rate of Discharge Fluid as measured at flow meter FM-2, gpm  
 $W_{FM-2}$  = The mass flow rate of the heat transfer fluid measured at the flow meter with the same numeric designation, i.e. FM-n, lb/min

Subscripts:

- Ch = Designates the value pertaining to a Charge Cycle  
 D = Designates the value pertaining to a Discharge Cycle  
 IC = Designates the value pertaining to an initial Charge Cycle  
 paras = Designates the value pertaining to a parasitic device such as an air pump

**E9.2 Averaging.** The test readings of temperature, flow rate, pressure, etc. taken at each of the Intervals comprising a Period of the test cycle shall be averaged and used as the value for that Period.

**E9.3 Initial Charge Capacity.** The initial charge capacity ( $Q_{IC}$ ) is equal to the heat absorbed by the Thermal Storage Device during the initial charge cycle test, less the heat gains from parasitics and the ambient over the duration of the initial charge cycle test. It is calculated as:

$$Q_{IC} = [(K_1) \int_{t_{IC1}}^{t_{ICF}} W_{FM-2} c_p (T_2 - T_1) dt] - Q_{paras} - Q_{amb} \quad E1$$

**E9.4 Net Usable Storage Capacity.** The Net Usable Storage Capacity is equal to the heat absorbed by the Thermal Storage Device during the discharge cycle. It is calculated by the following method:

$$Q_D = (K_1) \int_{t_{D1}}^{t_{DF}} W_{DFM-2} c_p (T_2 - T_1) dt \quad E2$$

**E9.5 Average Discharge Rate.** Determine the average Discharge Rate for each Period (p) (consisting of Intervals 1 through n) comprising the discharge cycle test as:

$$\overline{q_{Dp}} = (K_1) \left( \frac{1}{n} \right) \sum_{i=1}^n W_{DFM-2n} c_p (T_{2n} - T_{1n}) \quad E3$$

**E9.6 Parasitic Heat Gain.** The parasitic heat gain ( $Q_{paras}$ ) into the Thermal Storage Device during the charge cycle test and the discharge cycle test is determined as:

$$Q_{paras} = (K_1) [(\tau_{Ch paras}) (P_{Ch paras}) + (\tau_{D paras}) (P_{D paras})] \quad E4$$

Also, if the parasitic auxiliary is an air pump used for agitation of the storage media, the parasitic heat gain shall include the heat input to the Thermal Storage Device as the air is cooled from its source temperature to the temperature of the storage media:

$$Q_{air} = (K_1) (\dot{m}_{air}) (h_{source} - h_{sat}) \quad E5$$

**E9.7 Ambient Heat Gain.** The ambient heat gain into the Thermal Storage Device during the charge cycle Test and Discharge Cycle tests ( $Q_{amb}$ ) is determined as:

$$Q_{amb} = (K_1) (\tau_{Ch} + \tau_D) (q_{amb}) \left( \frac{T_{amb} - T_{sm}}{\Delta T_{des}} \right) \quad E6$$

**E9.8 Total Charge Capacity.** The total charge capacity ( $Q_{Ch}$ ) shall be calculated as follows:

$$Q_{Ch} = (K_1) \int_{t_{Ch_i}}^{t_{Ch_f}} W_{ChFM-1} c_p (T_1 - T_2) dt \quad E7$$

**E9.9 Average Charge Rate.** The average Charge Rate for each Period comprising the Charge Cycle shall be calculated as:

$$\overline{q_{Ch_p}} = (K_1) \left( \frac{1}{n} \right) \sum_{i=1}^n W_{ChFM-1_n} c_p (T_{1_n} - T_{2_n}) \quad E8$$

and the average Charge Rate over the duration of the Charge Cycle as:

$$\overline{q_{Ch}} = \left( \frac{Q_{Ch}}{\tau_{Ch}} \right) \quad E9$$

and the average initial Charge Rate over the duration of the initial Charge Cycle as:

$$\overline{q_{IC}} = \left( \frac{Q_{IC}}{\tau_{IC}} \right) \quad E10$$

For the initial charge cycle test to be valid, the following relationship shall hold:

$$\left| \frac{\overline{q_{IC}}}{\overline{q_{Ch}}} - 1 \right| \leq 0.05 \quad E11$$

**E9.10 Average Charge Temperatures.** The average charge temperatures will be the time weighted average of the entering and leaving temperatures over the entire charge cycle test. They shall be calculated as follows:

$$\overline{T_1} = \left( \frac{1}{\tau_{Ch}} \right) \int_{t_{Ch_i}}^{t_{Ch_f}} T_1 dt \quad E12$$

$$\overline{T_2} = \left( \frac{1}{\tau_{Ch}} \right) \int_{t_{Ch_i}}^{t_{Ch_f}} T_2 dt \quad E13$$

**E9.11 Initial Charge Time.** The initial charge time shall be equal to the time elapsed between the start and the end of the initial charge test. These data are required since the time required to initially charge the device may be longer than that required to recharge it because in some storage devices a residual charge may be left in the device to maintain proper performance. Therefore, it is important to know the time required to initially charge the device or to recharge it, if for some reason the device is totally discharged when in normal operation.

**E10** *Test Evaluation.*

**E10.1** *Procedure.* The thermal performance of the Thermal Storage Device shall be evaluated by comparing the measured test data averaged over each Period comprising the test cycle to the performance predicted by the manufacturer's rating methodology for the corresponding Period.

**E10.1.1** *Charge Cycle Test.* Using the average Charge Rate in Section E9.9 as the chiller capacity and the measured flow rate of the heat transfer fluid as input, determine the temperatures of the charging fluid entering and leaving the Thermal Storage Device as predicted by the manufacturer's rating methodology.

For the charge rating to be verified, the measured fluid temperatures averaged for each Period of the charge cycle test and the minimum fluid temperature entering the storage device as attained during the test cycle shall be no greater than 0.5°F above the corresponding values predicted by the rating methodology for that Period.

**E10.1.2** *Discharge Cycle Test.* Using the average Discharge Rate for each Period of the discharge cycle test, as determined in Section E9.5 for the load profile, and the corresponding measured flow rate of the heat transfer fluid as input for each Period, determine the temperatures of the Discharge Fluid entering and leaving the Thermal Storage Device for each Period, as predicted by the manufacturer's rating methodology.

For the discharge rating to be verified, the measured fluid temperatures averaged over each Period of the discharge cycle shall be no greater than 0.5°F above the corresponding values predicted by the rating methodology for that Period.

**E11** *Test Report.*

**E11.1** *General Information.* A written test report shall be prepared and distributed to the parties involved in the test. Included in the introduction to the report shall be:

- E11.1.1** The name and address of the test location
- E11.1.2** The name(s), title(s) and affiliation(s) of those persons conducting the test, witnessing the test, and preparing the test report. Also included shall be the name, title, and signature of the person(s) accepting responsibility for the content of the report
- E11.1.3** The date the test was conducted and the date of the report
- E11.1.4** The name and address of the client
- E11.1.5** The method by which the test unit was selected (i.e. random selection) and its condition

**E11.2** *Test Unit Description.* The report shall include a full description of the test unit, using as a minimum the data specified in Section E8.4.

**E11.3** *Test System Description.* A description of the test facility and primary apparatus shall be included in the report, complete with a system diagram showing the interconnecting piping and the locations of the principle components and instrumentation. Also included in this section shall be the specifics of the heat transfer fluid(s) employed for the test, including the basic data specified in Section E8.3.

**E11.4** *Test Unit Data.* The report shall include a summary of the unit performance with the following overall data and calculation results:

- E11.4.1** The Net Usable Storage Capacity,  $Q_D$ , ton-hour
- E11.4.2** The type of heat transfer fluid used
- E11.4.3** The duration of the initial Charge Cycle, h
- E11.4.4** The average Charge Rate ( $q_{IC}$ ) for the initial Charge Cycle, tons
- E11.4.5** The total capacity ( $Q_{IC}$ ) for the initial Charge Cycle, ton-hour
- E11.4.6** The time weighted average inlet and outlet temperatures for the initial Charge Cycle, °F
- E11.4.7** The minimum charge temperature for the initial Charge Cycle, °F
- E11.4.8** The duration during the discharge cycle, h
- E11.4.9** The average Discharge Rate ( $\overline{q_D}$ ) during the Discharge Cycle, tons

- E11.4.10** The maximum temperature attained by the heat transfer fluid leaving the storage device during the discharge cycle, °F
- E11.4.11** The duration of the Charge Cycle, h
- E11.4.12** The average Charge Rate ( $\overline{q_{Ch}}$ ) of the Charge Cycle, tons
- E11.4.13** The total capacity ( $Q_{Ch}$ ) of the Charge Cycle, ton-hour
- E11.4.14** The time weighted average inlet and outlet temperatures of the Charge Cycle, °F
- E11.4.15** The minimum charge temperature of the Charge Cycle, °F
- E11.4.16** The pressure drop of the heat transfer fluid across the Thermal Storage Device at the maximum flow rate, psi
- E11.4.17** Tables for both the Charge Cycle and the Discharge Cycle, listing the load for each Period and comparing the measured temperatures of the heat transfer fluid as it enters and leaves the Thermal Storage Device, averaged over each Period, to the temperatures predicted by the rating methodology for the corresponding Period (Table E1)
- E11.4.18** A copy of the performance of the Thermal Storage Device as predicted by the manufacturer's rating methodology when using the duration of the charge cycle test and the load profile imposed during the discharge cycle test as input

<b>Table E1. Temperature Comparison – Charge and Discharge Cycles</b>							
Period	Charge or Discharge Rate (q), tons	Temperature of Heat Transfer Fluid Entering Storage Device, °F			Temperature of Heat Transfer Fluid Leaving Storage Device, °F		
		Measured	Predicted	Difference	Measured	Predicted	Difference
#1							
#2							
#...							
#p							

**E11.5** *Calculation Summary.* The report shall include a summary sheet showing the results of all calculations for each reading along with an example of the complete calculations for one set of readings. Also included in this section shall be a statement of compliance with or deviation from the provisions in this standard.

**E11.6** *Raw Test Data.* The raw test data shall be compiled and recorded in a legible form and included in the report. Hard copy shall be included even if data are also stored on electronic media.

**E11.7** *Instrument Summary.* The report shall include a tabulation of all instruments used in the test, including the serial number, latest calibration date, and the means by which the instrument was calibrated.

# APPENDIX F. METHOD OF TESTING FOR RATING THERMAL STORAGE DEVICES WHICH EMPLOY DIFFERENT HEAT TRANSFER FLUIDS FOR THE CHARGE CYCLE AND THE DISCHARGE CYCLE – NORMATIVE

**F1** *Purpose.* The purpose of this appendix is to prescribe a method of testing to verify the performance and capacity of Thermal Storage Devices which employ one heat transfer fluid to charge the device and a second heat transfer fluid to discharge it.

**F1.1** *Intent.* The procedures set forth in this appendix are intended for use in situations where adequate facilities, equipment, instrumentation and load stability can be provided.

**F1.2** *Exemptions.* This procedure is not intended for testing typical field installations where facilities, equipment, and instrumentation differ from that specified in this standard and steady state conditions are virtually impossible to achieve.

**F2** *Scope.* This method of test applies only to latent Thermal Storage Devices (e.g. ice on coil – external melt), as defined in Section 4 of this standard, where, for example, an evaporating refrigerant is used as the heat transfer fluid during the charge cycle and water is used during the discharge cycle. (See other appendices for methods of testing applicable to other equipment classifications)

**F3** *Definitions.* Definitions for this appendix are identical to those in Section 3 of this standard.

**F4** *Method of Testing.*

**F4.1** *Test Method.* The complete test procedure includes a minimum of three individual test runs, the initial charge cycle test to determine the time required to initially charge the Thermal Storage Device, the discharge cycle test to verify the temperatures at which the Net Usable Storage Capacity of the device can be delivered, and the charge cycle test to verify the temperatures of the heat transfer fluid and refrigeration capacity required to recharge the device.

**F4.1.1** The initial charge cycle test shall determine the elapsed time required to bring the storage device to its fully charged condition and the minimum temperature of the heat transfer fluid attained during the cycle. It shall also determine the time weighted average inlet temperature ( $\overline{T}_5$ ), the time weighted average outlet temperature ( $\overline{T}_6$ ), the average charging rate ( $\overline{q}_{Ch}$ ) and the total heat removal required to bring the storage device to its fully charged condition ( $Q_{IC}$ ).

**F4.1.1.1** At the beginning of the initial charge test, the Thermal Storage Device shall be fully discharged, in the initial steady state condition as defined in Section F7.3.1.

**F4.1.1.2** The initial charge test shall employ the same average heat removal rate (charging rate) as the charge test in Section F7.2.2.

**F4.1.1.3** The initial charge cycle test shall be complete when the storage device has reached the fully charged condition as defined by the manufacturer's published criteria.

**F4.1.2** The discharge cycle test shall verify that the temperatures delivered for a specific imposed load agree, Period by Period, with those predicted by the manufacturer's Published Rating methodology when using the test load profile as input.

**F4.1.2.1** At the beginning of the discharge cycle test, the storage device shall be in its fully charged condition in accordance with the manufacturer's published criteria.

**F4.1.2.2** The discharge cycle test shall be conducted with the mixed temperature, as measured at sensor TS-1, held at a preset value by the temperature actuated mixing valve (TMV-1, Figure F1).



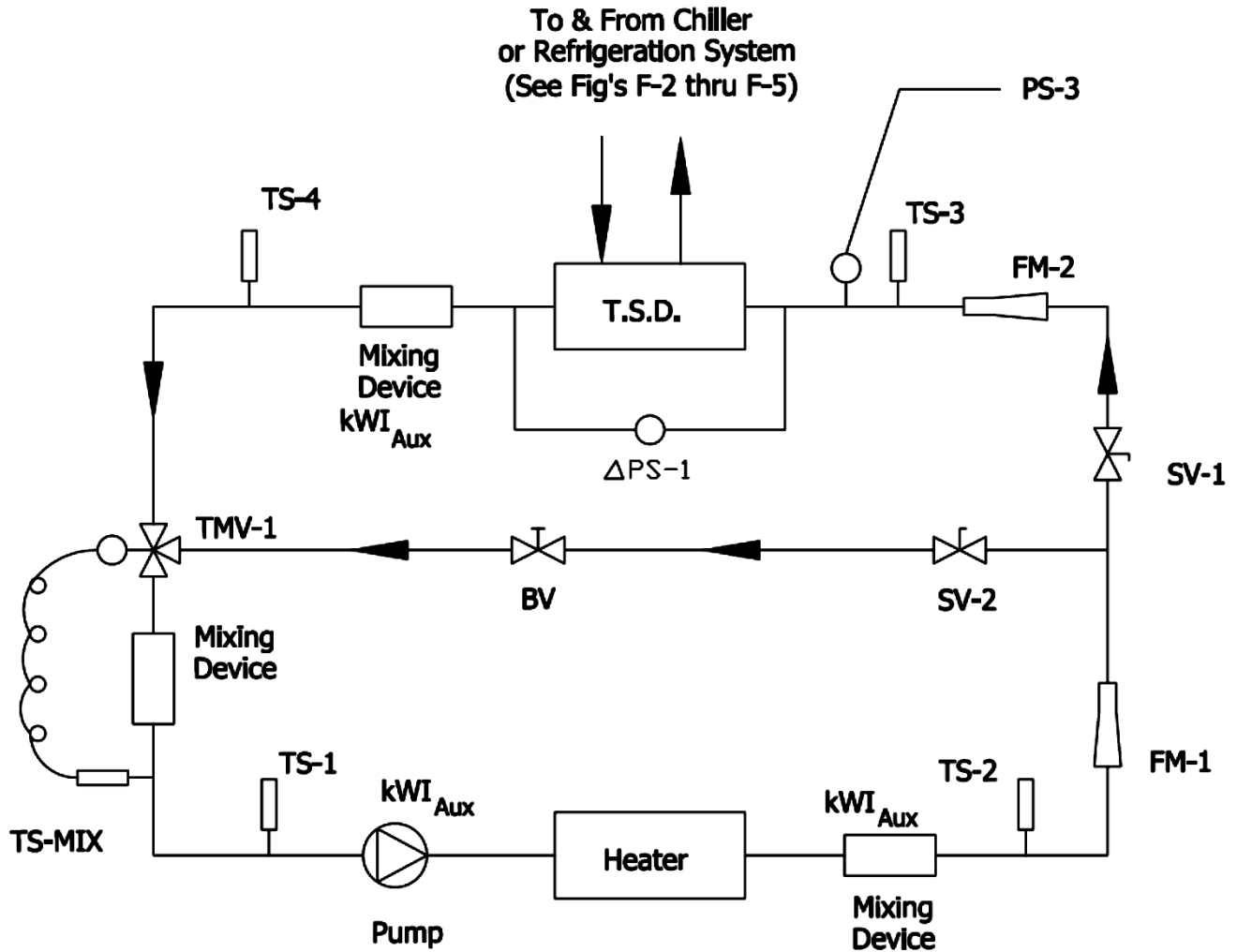

Figure F1. Discharge Cycle Test Apparatus

Where:

- |             |   |                              |        |   |                                   |
|-------------|---|------------------------------|--------|---|-----------------------------------|
| BV          | = | Balancing Valve              | SV     | = | Shut-Off Valve                    |
| $\Delta$ PS | = | Differential Pressure Sensor | TMV    | = | Temperature Actuated Mixing Valve |
| FM          | = | Flow meter                   | TS     | = | Temperature Sensor                |
| kWI         | = | Kilowatt Input               | T.S.D. | = | Thermal Storage Device            |
| PS          | = | Pressure Sensor              | TXV    | = | Thermostatic Expansion Valve      |

**F4.1.2.3** The discharge cycle test shall be complete when the Net Usable Storage Capacity ( $Q_D$ ) claimed for the imposed load profile has been removed from the device. (Note: As discussed in Section F9.11, some residual cooling may still remain in the Thermal Storage Device at this point since the duration of the discharge cycle test is solely a function of the temperature produced at TS-1, not the state of charge of the Thermal Storage Device.)

**F4.1.3** The charge cycle test shall verify that the temperatures of the heat transfer fluid required to recharge the device agree, Period by Period, with those predicted by the manufacturer's rating methodology when using as input the refrigeration/chiller capacity actually delivered during the test. It shall also determine the time weighted average inlet temperature ( $\overline{T}_5$ ), the time weighted average outlet temperature ( $\overline{T}_6$ ), the minimum inlet temperature ( $T_{5\min}$ ), the average charging rate ( $\overline{q_{Ch}}$ ) and the total heat removal ( $Q_{Ch}$ ) required to return the storage device to its fully charged condition.

**F4.1.3.1** At the beginning of the charge cycle test, the storage device shall be in the state of discharge reached at the end of the discharge cycle test as described in Section F4.1.2.3.

**F4.1.3.2** *The Charge Cycle Test.* The charge cycle test shall be complete when the storage device has been returned to its initial fully charged condition as defined in Section F4.1.1.3.

**F4.2** *Data to be Taken.* The following data will be measured and recorded at Intervals not exceeding 5 minutes over the duration of each cycle test.

**F4.2.1** Initial charge and charge cycle tests on Thermal Storage Devices using a Secondary Coolant as the heat transfer fluid to charge the device (Figure F2).

**F4.2.1.1** The flow rate of the Secondary Coolant flowing through the Thermal Storage Device as measured at FM-3.

**F4.2.1.2** The temperatures of the Secondary Coolant as it enters and leaves the Thermal Storage Device,  $T_5$ , and  $T_6$ , respectively

**F4.2.1.3** The pressure drop of the Secondary Coolant across the Thermal Storage Device ( $\Delta PS-2$ )

**F4.2.1.4** The power input to the compressor, ( $kWI_{cm}$ )

**F4.2.1.5** The power input to any auxiliary equipment such as air pumps, agitators, etc. that are required by the storage device to produce the rated capacity during the charge or discharge cycle,  $kWI_{Aux}$

**F4.2.1.6** One measurement of the refractive index of the Secondary Coolant during the charge cycle test

**F4.2.1.7** The water flow rate to the water cooled condenser as measured at flow meter FM-4

**F4.2.1.8** The temperature of the condenser water as it enters and leaves the water cooled condenser ( $T_9$ ) and ( $T_{10}$ )

**F4.2.2** Initial charge and charge cycle tests on Thermal Storage Devices using a refrigerant as the heat transfer fluid during the Charging Cycle (Figures F-3 through F-5)

**F4.2.2.1** The mass flow rate of the liquid refrigerant as it enters the expansion valve or low side float valve, as measured by refrigerant flow meter FM-3 (Figures F-3 through F-5)

**F4.2.2.2** The pressure ( $P_5$ ) and temperature ( $T_5$ ) of the liquid refrigerant as it enters the expansion valve or low side float valve

**F4.2.2.3** The pressure ( $P_6$ ) and temperature ( $T_6$ ) of the refrigerant vapor at the suction connection of the Thermal Storage Device on direct expansion feed systems or the low pressure receiver or surge drum on liquid systems

**F4.2.2.4** The pressure ( $P_7$ ) and the temperature ( $T_7$ ) of the superheated refrigerant as it enters the condenser

F4.2.2.5 The pressure ( $P_8$ ) and the temperature ( $T_8$ ) of the subcooled refrigerant as it leaves the condenser

F4.2.2.6 The power input to the compressor, ( $kW_{I_{cm}}$ )

F4.2.2.7 The power input to any auxiliary equipment such as air pumps, agitators, etc. that are required by the storage device to produce the rated capacity during the charge cycle, ( $kW_{I_{Aux}}$ )

F4.2.2.8 The water flow rate to the water cooled condenser as measured at flow meter FM-4

F4.2.2.9 The temperature of the water entering ( $T_9$ ) and leaving ( $T_{10}$ ) the water cooled condenser

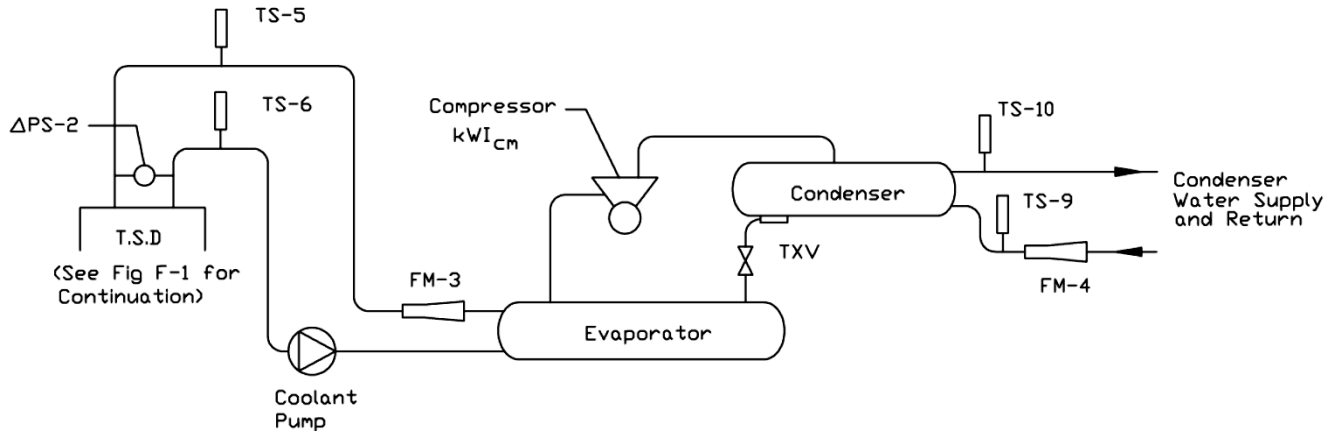

Figure F2. Refrigeration System with Secondary Coolant

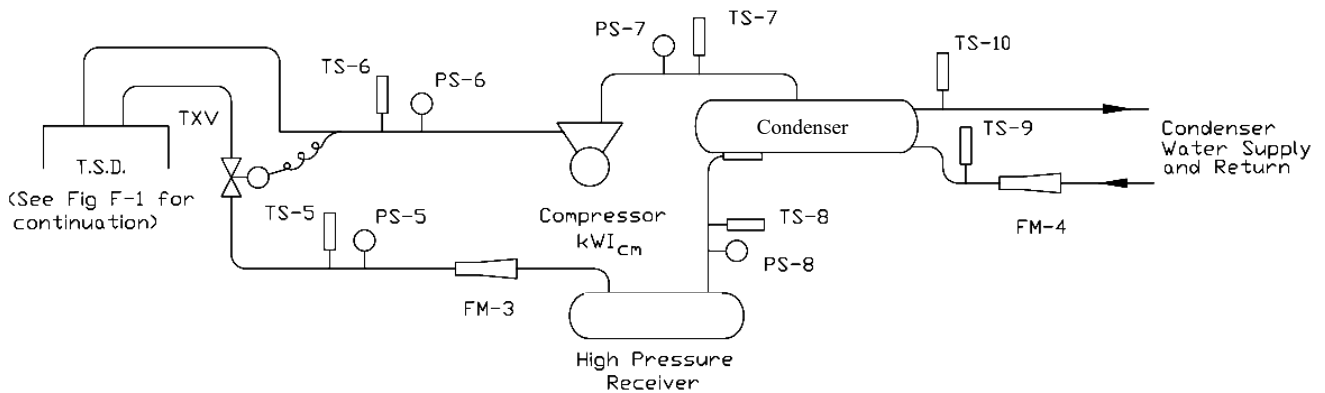

Figure F3. Refrigeration System with Direct Expansion Feed

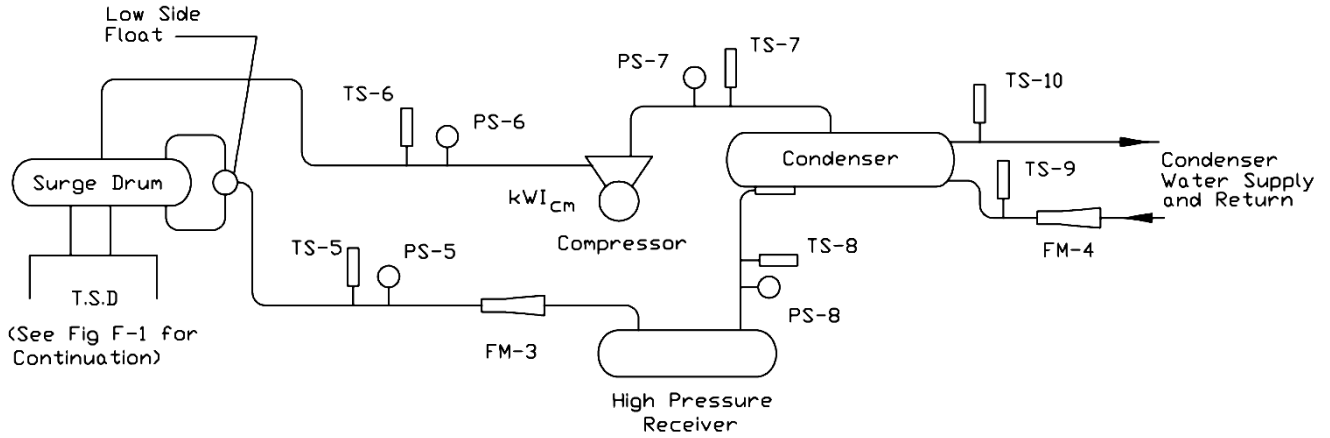

Figure F4. Refrigeration System with Gravity Feed

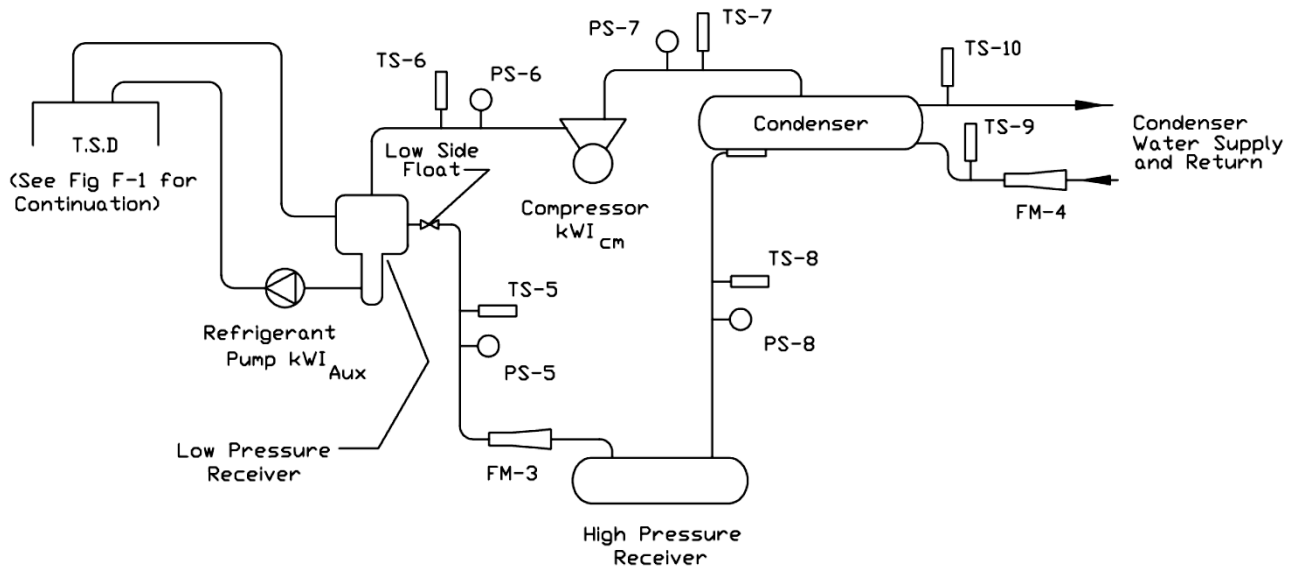

Figure F5. Refrigeration System with Pumped Overfeed

**F4.2.3** During the discharge cycle test on Thermal Storage Devices, the following data will be measured and recorded at Intervals not exceeding 5 minutes over the duration of the test:

**F4.2.3.1** The flow rate of the water (or Secondary Coolant) flowing through the Thermal Storage Device as measured at FM-2. (Figure F1)

**F4.2.3.2** The temperatures of the water (or Secondary Coolant) entering ( $T_3$ ) and leaving ( $T_4$ ) the Thermal Storage Device

**F4.2.3.3** Confirming measurements of the temperatures and flow rate of the water or Secondary Coolant at TS-1, TS-2, and FM-1 respectively

**F4.2.3.4** The pressure drop of the heat transfer fluid across the Thermal Storage Device ( $\Delta PS-1$ )

**F4.2.3.5** The power input to any auxiliary equipment such as air pumps, agitators, etc. that are required by the storage device to produce the rated capacity during the discharge cycle, ( $kW_{I_{Aux}}$ )

**F5** *Instruments.*

**F5.1** *General.* Instruments (or instrument systems) shall be selected to meet the requirements and accuracies specified in the following subsections.

**F5.1.1** Instrument calibrations shall be traceable to primary or secondary standards calibrated by the National Institute of Standards and Technology. The indicated corrections shall be applied to obtain the required accuracy. Instruments shall be recalibrated on a regular schedule appropriate for the respective instruments, and full calibration records shall be maintained.

**F5.1.2** All instruments shall be applied and used in accordance with the standards specified for that type of instrument and in a manner that ensures compliance with the specified accuracy.

**F5.2** *Temperature Measurements.* Temperature measurements shall be made in accordance with ANSI/ASHRAE Standard 41.1 with instruments having accuracies within the limits specified for the following measurements:

**F5.2.1** Individual refrigerant, water, and other heat transfer fluids, or air dry-bulb temperatures:  $\pm 0.10^{\circ}F$

**F5.2.2** Temperature differences in refrigerant and water within 2% of the numerical value of the difference being measured

**F5.3** *Pressure Measurements.* Pressure measurements shall be made in accordance with ANSI/ASHRAE Standard 41.3 and ASME PTC 19.2. The accuracy of instruments for measuring the pressure of fluids and the pressure differential across the Thermal Storage Device shall permit determination of the pressure or pressure differential within 2% of the numerical value of the quantity being measured.

**F5.4** *Electrical Measurements and Instruments.* Electric power measurements shall be made at a location such that the instrumentation can accurately measure the total power input to the device. The instrumentation used shall measure true rms power within 1% of the quantity measured. Test sites that utilize power-altering equipment may require appropriate isolation and precautions between the measurement point and the load device to ensure that accurate power measurements are obtained.

**F5.5** *Flow Measurements.* Flow rates of heat transfer fluids (including refrigerants) shall be measured in accordance with ASHRAE Standard 41.8 and the appropriate apparatus standard listed below for the instrument being used. Instruments shall have accuracies within 1% of the quantity measured. The instruments that may be used to measure the flow of heat transfer fluids include the following:

Calorimeters	ANSI/ASHRAE 41.9
Coriolis Meters	ASME MFC-11M
Electromagnetic Meters	ASME MFC-16
Flow Nozzles	ASME MFC-3M
Orifices	ASME MFC-3M
Turbine Meters	ASME MFC-4M
Ultrasonic Meters	ASME MFC-5M
Venturi Meters	ASME MFC-3M
Vortex Meters	ASME MFC-6M

**F5.5.1** *Calorimeter.* Sensible type calorimeters (Figure F6) can also be used to determine flow rate. By measuring the mass flow rate and the temperature range of water used to heat or cool the second fluid, the load on the water side can be determined. Dividing this load by the enthalpy change of the second fluid (determined by the temperature/pressure measurement) yields the mass flow rate of the second fluid. Alternatively, steam or electric heat, with the appropriate instrumentation, can be used as a load source.

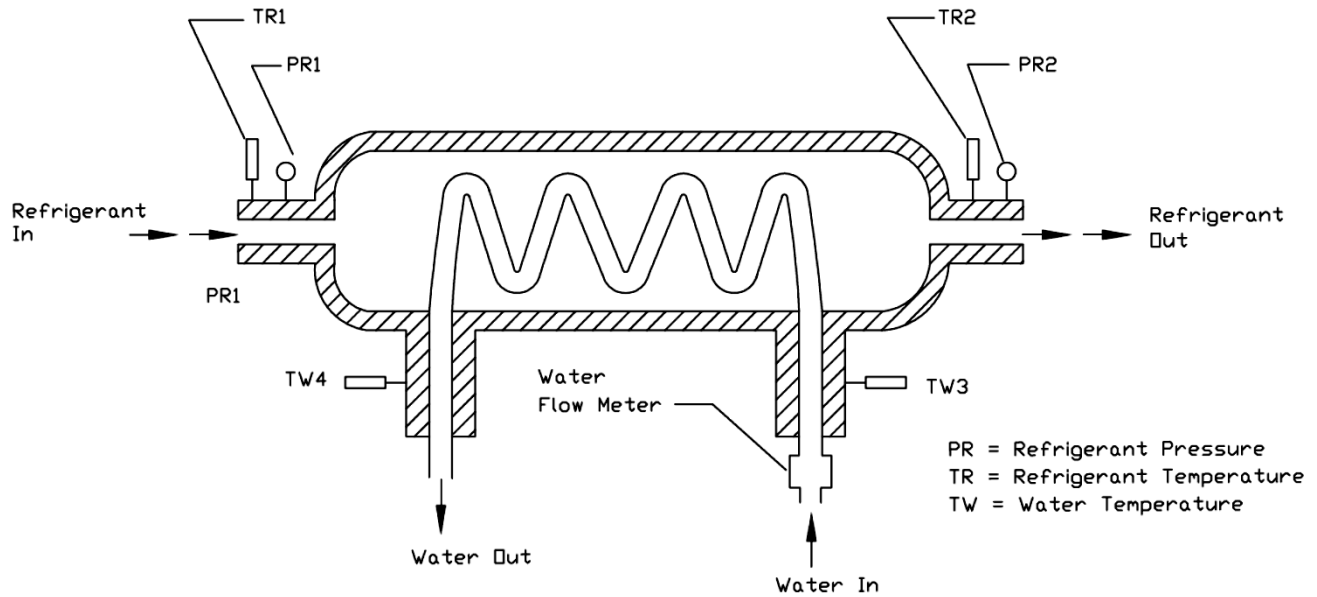

**Figure F6. Typical Calorimeter Instrument**

**F5.5.1.1** For measurement of liquid refrigerant flow, the refrigerant at any point in the heat exchanger shall be subcooled by at least 10°F to ensure the liquid remains in single phase.

**F5.5.1.2** For measurement of vapor refrigerant flow, the refrigerant at any point in the heat exchanger shall be superheated by at least 20°F to ensure the vapor remains in single phase.

**F5.6 Time Measurements.** Time measurements shall be made with instruments having accuracies of  $\pm 0.5\%$  of the elapsed time measured. This accuracy will include any uncertainty errors associated with starting and stopping the instrument.

**F5.7 Physical and Thermodynamic Properties.** The physical and thermodynamic properties of fluids shall be determined from the following sources:

**F5.7.1** The heat transfer and thermodynamic properties of water shall be taken from the *ASHRAE Handbook Fundamentals*.

**F5.7.2** The heat transfer and thermodynamic properties of Secondary Coolants shall be taken from the *ASHRAE Handbook Fundamentals*, based on the refractive index measurements taken during the test(s).

**F5.7.2.1** Refractive index measurements shall be converted to concentration (in percent by volume) of the heat transfer fluid using standard conversion tables.

**F5.7.2.2** The properties shall be interpolated from data published in the *ASHRAE Handbook Fundamentals* at the concentration corresponding to the measured refractive index and a temperature representative of the fluid at the point of interest.

**F5.7.3** The physical and thermodynamic properties of refrigerants shall be taken from *ASHRAE Thermodynamic Properties of Refrigerants*. For refrigerants not listed in this source, *NIST Thermodynamic Properties of Refrigerants and Refrigerant Mixtures Database* or publications distributed by refrigerant manufacturers may be used. In all cases, the source from which the data are taken shall be stated in the test report.

**F6** *Apparatus.*

**F6.1** *Configuration.* The test apparatus shall be comprised of two distinct parts, a discharge cycle test apparatus and a refrigeration system for the charge cycle tests.

**F6.1.1** The discharge cycle test apparatus may be of open or closed loop design and, as a minimum, shall consist of a heat source, a circulating pump, a mixing valve, interconnecting piping, and instrumentation, as shown in Figure F1.

**F6.1.2** The refrigeration system for the charge cycle tests, as a minimum, shall be comprised of a compressor, a water cooled condenser, the necessary controls, instrumentation and, as may be necessary for the type of Thermal Storage Device under test, a high pressure receiver, an evaporator, a surge drum, or a low pressure receiver (Figures F-3 through F-5).

**F6.1.3** The water cooled refrigerant condenser serves as a calorimeter to provide confirming test data during the initial charge and charge cycle tests.

**F6.2** *Piping for Secondary Coolants.* The piping to which differential pressure measuring devices ( $\Delta$ PS-1 and  $\Delta$ PS-2) are connected shall be of the same diameter on both the inlet and the outlet of the Thermal Storage Device.

**F6.3** *Insulation.* The piping for the heat transfer fluids shall be sufficiently insulated to minimize the heat losses that would otherwise affect the validity of the primary and confirming capacity measurements.

**F7** *Test Procedure.***F7.1** *Preparation for Test.*

**F7.1.1** The storage device shall be installed in the test loop, as shown in Figures F-1 through F-5, in accordance with the manufacturer's installation instructions. If located outdoors, the storage device shall be shielded from direct sunlight and protected from wind.

**F7.1.2** After installation and before testing, the unit shall be cycled (charged and discharged) as recommended by the manufacturer.

**F7.2** *Operational Limits and Test Requirements.*

**F7.2.1** The duration and Charge Rate of the charge cycle test shall be determined prior to the test.

**F7.2.2** The initial charge test and the charge cycle test shall employ the same average heat removal rate (Charge Rate) over the duration of the test, the value of which shall be within 10% of the rate agreed to by the parties to the test. The capacity of the compression equipment shall not be mechanically altered during either test and for the tests to be valid, the average heat removal rate of the initial charge cycle test shall be within 10% of the average heat removal rate of the charge cycle test.

**F7.2.3** The duration of the discharge cycle test and the profile of the load imposed on the Thermal Storage Device shall be determined prior to the test. The duration of the discharge cycle test shall be within 10% of the specified duration and the load imposed during each Period shall be within 10% of the specified value.

**F7.2.4** Steady state flow of the discharge heat transfer fluid, as measured at FM-1, shall be maintained over the duration of the discharge test cycle. This shall be considered to have been achieved if the measured flow rate varies by less than 5% over the duration of the discharge cycle test.

**F7.2.5** The total heat removed from the Thermal Storage Device during the initial charge cycle test ( $Q_{IC}$ ) or the charge cycle test ( $Q_{Ch}$ ) shall be determined using the flow rate of the heat transfer fluid as measured at FM-3 and the temperatures/enthalpies of the heat transfer fluid as determined from measurements at sensors TS-5/PS-5 and TS-6/PS-6.

**F7.2.6** The total heat added to the Thermal Storage Device during the discharge cycle test ( $Q_D$ ) shall be determined using the flow rate of the heat transfer fluid as measured at FM-2 and the temperatures of the heat transfer fluid as measured at sensors TS-3 and TS-4.

**F7.2.7** After correcting the calculated values of total heat removed and total heat added for ambient and parasitic heat gains ( $Q_{amb}$  and  $Q_{paras}$ ), the total heat input during the discharge cycle test ( $Q_D$ ) shall be within 5% of the total heat removed during the charge cycle test ( $Q_{Ch}$ ).

**F7.2.8** The confirming test of the discharge cycle test shall consist of measuring and recording the flow rate and temperatures of the heat transfer fluid at flow meter FM-1 and temperature sensors, TS-1 and TS-2. These values shall be used to calculate the total heat added to the storage device over the duration of the discharge cycle test. For the discharge cycle test to be valid, the result of this confirming test shall agree within 3% of the primary test value.

**F7.2.9** The confirming test of the charge cycle test shall consist of measuring and recording the flow rate and temperatures of the condenser water at flow meter FM-4 and temperature sensors, TS-9 and TS-10. This data shall be used in conjunction with the power input to the compressor to calculate the total heat removed from the Thermal Storage Device over the duration of the charge cycle test. For the charge cycle test to be valid, the result of the confirming test shall agree within 5% of the primary test value.

**F7.3** *Test Sequence.* A full test shall consist of an initial charge cycle test, a discharge cycle test, and a charge cycle test, conducted in the following sequence:

**F7.3.1** *Initial Steady State Condition.* With the Thermal Storage Device in the fully discharged condition and service valve SV-2 fully closed, the heat transfer fluid shall be circulated through the discharge cycle test apparatus and the Thermal Storage Device until the initial steady state condition is established. Initial steady state shall be considered achieved when the temperature measured at TS-1 is constant at 13°F above the phase change temperature of the storage media and the temperatures measured at TS-1, TS-2, TS-3, and TS-4 are all equal within the specified accuracies of the instruments.

**F7.3.2** *Changeover Period I.* During this and all subsequent changeover Periods, secondary sources of heat (such as auxiliary heaters, agitation systems in the Thermal Storage Device, etc.) shall be turned off. During this first changeover Period, the capacity of the refrigeration system, the flow rates and valves shall be adjusted for the initial charge cycle test. When all components are set, the chiller/refrigeration system shall be turned on.

**F7.3.3** *Initial Charge Cycle.* The Initial Charge Cycle shall be conducted at an average Charge Rate which shall be within 10% of the average rate used during the charge cycle test in Sections F7.2.2 and F7.3.7, with no mechanical unloading of the compressor during the test. During the initial charge cycle, any agitation devices or other auxiliary equipment furnished with the device shall be operated in accordance with the manufacturer's published instructions. The initial charge cycle shall end when the storage device is fully charged in accordance with the manufacturer's published instructions.

**F7.3.4** *Changeover Period II.* Immediately after the initial Charge Cycle, with the Thermal Storage Device fully charged, adjust the valve settings to set the flow rate of the heat transfer fluid for the discharge cycle test.

**F7.3.5** *Discharge Cycle Test.* The discharge cycle test begins when the heat source and the temperature actuated mixing valve, TMV-1, are activated. During this discharge cycle test, any agitation devices normally furnished with the Thermal Storage Device shall be operated in accordance with the manufacturer's published instructions. The discharge test cycle ends when the Net Usable Storage Capacity ( $Q_D$ ) claimed for the device has been removed, at which point the heat source is deactivated.

**F7.3.6** *Changeover Period III.* Immediately upon completion of the discharge cycle test, flow through the storage device shall be stopped and valves adjusted for the charge cycle test. When all components are set, the chiller/refrigeration system shall be turned on.

**F7.3.7** *Charge Cycle Test.* During the charge cycle test, an essentially constant charging rate (i.e. no mechanical unloading of the compressor throughout the test), as defined in Section F7.2.2, shall be maintained



and any agitation devices normally furnished with the Thermal Storage Device shall be operated in accordance with the manufacturer's published instructions. The charge cycle test shall end when the unit is fully charged as defined by the manufacturer's published instructions.

**F7.3.8 Final Steady State Condition.** Once the Thermal Storage Device has reached the fully charged condition, the test series is completed.

**F8** *Data to be Recorded.*

**F8.1 Test Data.** The following test data shall be measured and recorded at evenly spaced Intervals not exceeding 5 minutes in duration over the full duration of each initial charge cycle, charge cycle, and discharge cycle test.

**F8.1.1 Initial Charge and Charge Cycle Tests using a Refrigerant as the Heat Transfer Fluid (Figures F-3, F-4, and F-5).**

**F8.1.1.1** Type of Refrigerant used

**F8.1.1.2** Temperature of the Refrigerant at locations TS-5, TS-6, TS-7, TS-8, °F

**F8.1.1.3** Pressure of the Refrigerant at locations PS-5, PS-6, PS-7, and PS-8, psi

**F8.1.1.4** Temperature of condenser water at locations TS-9 and TS-10, °F

**F8.1.1.5** Temperature of the Ambient Air,  $T_{amb}$ , °F

**F8.1.1.6** Flow rate of the heat transfer fluids at locations FM-3 and FM-4, gpm or lb/min

**F8.1.1.7** Power input to the compressor motor(s), kW

**F8.1.1.8** Time the test cycle was initiated and completed

**F8.1.2 Initial Charge and Charge Cycle Tests using a Secondary Coolant as the Heat Transfer Fluid (Figure F2).**

**F8.1.2.1** Temperature of the Secondary Coolant at locations TS-5 and TS-6, °F

**F8.1.2.2** Flow rate of the Secondary Coolant at location FM-3, gpm

**F8.1.2.3** Temperature of condenser water at locations TS-9 and TS-10, °F

**F8.1.2.4** Flow rate of condenser water at location FM-4, gpm

**F8.1.2.5** Temperature of the Ambient Air,  $T_{amb}$ , °F

**F8.1.2.6** Description of heat transfer fluids used, including refractive index where applicable (only one reading per test)

**F8.1.2.7** Power input to the compressor motor(s) ( $kWI_{cm}$ ), kW

**F8.1.2.8** Time the test cycle was initiated and completed

**F8.1.3 Discharge Cycle Test (Figure F1).**

**F8.1.3.1** Temperature of the heat transfer fluid at locations TS-1, TS-2, TS-3, and TS-4, °F

**F8.1.3.2** Temperature of the Ambient Air,  $T_{amb}$ , °F

**F8.1.3.3** Flow rate of the heat transfer fluid at locations FM-1 and FM-2, gpm or lb/min

**F8.1.3.4** Differential pressure of the heat transfer fluid across the Thermal Storage Device,  $\Delta PS-1$ , psi

**F8.1.3.5** Time the test cycle was initiated and completed

**F8.2 Test Data for Auxiliaries.** If liquid pumps or air pumps are required for the proper operation of the storage device, the following additional data shall be recorded at evenly spaced Intervals not exceeding 30 minutes in duration.

**F8.2.1** Power consumption of accessory pump or air compressor ( $kWI_{Aux}$ ), kW

**F8.2.2** The duration of operation if less than the full test cycle, h

**F8.2.3** Temperature of supply liquid or air to any such accessories, °F

**F8.2.4** Flow rate of liquid, gpm or air, cfm

**F8.3** *Data of Record.* The following data of record shall be taken and included in the test report:

- F8.3.1** Date, place and time of test
- F8.3.2** Names of test supervisors, technicians and witnessing personnel

**F8.4** *Thermal Storage Unit Data.* The following product data shall be recorded and included in the test report:

- F8.4.1** Manufacturer's name and address
- F8.4.2** Model number, serial number, and all nameplate data of the Thermal Storage Device
- F8.4.3** Manufacturer's Net Usable Storage Capacity, ton-hour
- F8.4.4** Storage medium
- F8.4.5** Specifics on heat transfer fluid(s) used to charge and discharge the Thermal Storage Device, including:
  - F8.4.5.1** Name of the manufacturer
  - F8.4.5.2** Name/description of the heat transfer fluids
  - F8.4.5.3** Refractive index of glycol based Secondary Coolants
  - F8.4.5.4** Density of Secondary Coolants at 15.6°C, lb/ft<sup>3</sup>
  - F8.4.5.5** Specific heat of Secondary Coolants at 15.6°F, Btu/lb · °F
- F8.4.6** Overall Dimensions of the Thermal Storage Device, in
- F8.4.7** Materials of construction of heat exchanger and/or storage vessel
- F8.4.8** Maximum operating pressure of the heat exchanger and/or storage vessel, psi
- F8.4.9** Maximum operating temperature of the heat exchanger and/or storage vessel, °F
- F8.4.9** Maximum allowable flow rate of heat transfer fluid(s), gpm
- F8.4.10** Minimum allowable flow rate of heat transfer fluid(s), gpm
- F8.4.11** The quantity and type of auxiliaries (including agitation devices if employed) and the power requirements and nameplate data for each

**F9** *Calculation of Results.*

**F9.1** *Nomenclature, Symbols, and Subscripts.*

Symbols:

- $c_p$  = Specific heat at constant pressure, Btu/lb · °F
- $h_{R_n}$  = The enthalpy of a refrigerant as determined from the temperature and pressure measurements at measurement point "n", Btu/lb
- $h_{source}$  = The enthalpy of the air being used to agitate the storage media in a Thermal Storage Device, at the source temperature and humidity, Btu/lb moist air
- $h_{sat}$  = The enthalpy of saturated air at the temperature of the storage media in a Thermal Storage Device, Btu/lb moist air
- $K_1$  = A constant as may be required to correct for units of measure
- $K_2$  = A factor for converting units of electric power to units of heat equal to 3,413 for I-P
- $kW_{ICM}$  = The measured electrical power input to the compressor motor, kW
- $kW_{IAux}$  = The measured electrical power input to the auxiliaries, kW
- $\dot{m}_{air}$  = The mass flow rate of air used to agitate the storage media in a Thermal Storage Device, lb/hr
- $n$  = The number of test readings taken during each Period comprising a test cycle

$p$	=	The number of Periods comprising a test cycle
$P_{Ch\ paras}$	=	The shaft power of a parasitic device operating during the charge cycle test, tons
$P_{D\ paras}$	=	The shaft power of a parasitic device operating during the discharge cycle test, tons
$P_n$	=	Pressure measured at the pressure sensor with the same numeric designation, i.e. PS-n, psi
$P_{CM}$	=	The energy added to the refrigerant vapor by the compressor including the motor cooling where applicable, Btu/h
$Q_{air}$	=	The calculated heat input to a Thermal Storage Device from air used to agitate the storage media, ton-hour
$Q_{amb}$	=	The calculated heat input to the Thermal Storage Device from the ambient over the duration of the charge cycle test and discharge cycle test, ton-hour
$Q_{Ch}$	=	Total Charge Capacity, ton-hour
$Q_D$	=	Net Useable Storage Capacity, ton-hour
$Q_{IC}$	=	Initial charge capacity, as determined from the initial charge cycle test, ton-hour
$Q_{paras}$	=	The calculated heat input to the Thermal Storage Device from parasitic devices operating during the charge cycle test and discharge cycle test, ton-hour
$q_{amb}$	=	The rate of heat gain from the ambient into the Thermal Storage Device at a specified temperature difference between the ambient and thermal storage media, ton
$\overline{q}_{Ch}$	=	Average Charge Rate, tons
$\overline{q}_{IC}$	=	Initial average Charge Rate, tons
$\overline{q}_{Ch_p}$	=	The average Charge Rate for one of the Periods (p) (consisting of Intervals 1 through n) comprising the charge cycle test, tons
$\overline{q}_{D_p}$	=	The average Discharge Rate for one of the Periods (p) (consisting of Intervals 1 through n) comprising the discharge cycle test, tons
$T_{amb}$	=	The temperature of the Ambient Air surrounding the Thermal Storage Device, °F
$\Delta T_{des}$	=	The design temperature difference between the ambient and the storage media for which the value of the heat gain rate ( $q_{amb}$ ) is valid, °F
$T_n$	=	Temperature measured at the temperature sensor with the same numeric designation, i.e. TS-n, °F
$\overline{T}_n$	=	The time weighted average temperature measured at the temperature sensor with the same numeric designation, i.e. TS-n, °F
$\overline{T}_5$	=	Time weighted average inlet temperature
$\overline{T}_{5\ min}$	=	Minimum inlet temperature
$\overline{T}_6$	=	Time weighted average outlet temperature
$T_{sm}$	=	The temperature of the storage media in the Thermal Storage Device, °F
$t_{ch_i}$	=	Time at start of charge cycle test
$t_{ch_f}$	=	Time at finish of charge cycle test
$t_{D_i}$	=	Time at start of discharge cycle test
$t_{D_f}$	=	Time at finish of discharge cycle test
$t_{IC_i}$	=	Time at start of initial charge cycle test
$t_{IC_f}$	=	Time at finish of initial charge cycle test
$\tau_{Ch}$	=	Duration of the charge cycle test, h
$\tau_{Ch\ paras}$	=	Total Period of operation of a parasitic device during the charge cycle test, h

$\tau_D$	=	Duration of the discharge cycle test, h
$\tau_{D \text{ paras}}$	=	Total Period of operation of a parasitic device during the discharge cycle test, h
$\tau_{IC}$	=	Duration of initial charge cycle test, h
$W_{CdFM-4}$	=	Mass flow rate of the heat transfer fluid used as a heat sink for the refrigerant condenser, as determined from flow meter FM-4, lb/min
$W_{ChFM-n}$	=	Mass flow rate of the Secondary Coolant used to charge the Thermal Storage Device as determined from flow meter FM-3 in Figure F2, lb/min
$W_{DFM-n}$	=	Mass flow rate of the heat transfer fluid used to discharge the Thermal Storage Device as determined from flow meter FM-1 or flow meter FM-2 in Figure F1, lb/min
$W_R$	=	Mass flow rate of refrigerant as determined by flow meter FM-3 in Figures F-3, F-4, and F-5, lb/min
$W_{FM-2}$	=	The mass flow rate of the heat transfer fluid measured at the flow meter with the same numeric designation, i.e. FM-n, lb/min
$\eta_{\text{drive}}$	=	Drive efficiency
$\eta_{\text{motor}}$	=	Efficiency, typical of an electric motor

Subscripts:

Cd	=	Designates the value pertaining to the refrigerant condenser
Ch	=	Designates the value pertaining to a Charge Cycle
CM	=	Designates the value pertaining to the compressor motor
D	=	Designates the value pertaining to Discharge Cycle
IC	=	Designates the value pertaining to an initial Charge Cycle
paras	=	Designates the value pertaining to a parasitic device such as an air pump
primary	=	Designates primary test
confirm	=	Designates confirming test

**F9.2 Averaging.** The test readings of temperature, flow rate, pressure, etc. taken at each of the Intervals comprising a Period of the test cycle shall be averaged and used as the value for that Period.

**F9.3 Initial Charge Capacity.** The initial charge capacity ( $Q_{IC}$ ) is equal to the heat removed from the Thermal Storage Device during the initial charge cycle test, less the heat gains from parasitics and the ambient over the duration of the initial Charge Cycle. It is calculated as:

$$Q_{IC} = (K_1) \int_{t_{IC1}}^{t_{ICF}} W_{FM-2} c_p (T_4 - T_3) dt - Q_{\text{paras}} - Q_{\text{amb}} \quad \text{F1}$$

**F9.4 Net Usable Storage Capacity.** The Net Usable Storage Capacity ( $Q_D$ ) is equal to the heat absorbed by the Thermal Storage Device during the discharge cycle test. For the primary test, it is calculated as:

$$Q_D = Q_{D_{\text{primary}}} = (K_1) \int_{t_{D1}}^{t_{DF}} W_{DFM-2} c_p (T_3 - T_4) dt \quad \text{F2}$$

and for the confirming test:

$$Q_{D_{confirm}} = (K_1) \int_{t_{D1}}^{t_{DF}} W_{DFM-1} c_p (T_2 - T_1) dt \quad F3$$

For a valid test, the following relationship shall hold true:

$$\left| \frac{Q_{D_{confirm}}}{Q_{D_{primary}}} - 1 \right| \leq 0.03 \quad F4$$

**F9.5 Average Discharge Rate.** Determine the average Discharge Rate for each Period (p) (consisting of Intervals 1 through n) comprising the discharge cycle test as:

$$\overline{q_{Dp}} = (K_1) \left( \frac{1}{n} \right) \sum_{i=1}^n W_{FM-2n} c_p (T_{3n} - T_{4n}) \quad F5$$

**F9.6 Parasitic Heat Gain.** The parasitic heat gain into the Thermal Storage Device during the charge cycle test and the discharge cycle test ( $Q_{paras}$ ) is determined as:

$$Q_{paras} = (K_1) [ (\tau_{Ch_{paras}}) (P_{Ch_{paras}}) + (\tau_{D_{paras}}) (P_{D_{paras}}) ] \quad F6$$

Also, if the parasitic auxiliary is an air pump used for agitation of the storage media, the parasitic heat gain shall include the heat input to the Thermal Storage Device as the air is cooled from its source temperature to the temperature of the storage media:

$$Q_{air} = (K_1) (\dot{m}_{air}) (h_{source} - h_{sat}) \quad F7$$

**F9.7 Ambient Heat Gain.** The ambient heat gain into the Thermal Storage Device during the charge cycle and discharge cycle tests ( $Q_{amb}$ ) is determined as:

$$Q_{amb} = (K_1) (\tau_{Ch} + \tau_D) (q_{amb}) \left( \frac{T_{amb} - T_{sm}}{\Delta T_{des}} \right) \quad F8$$

**F9.8 Total Charge Capacity and Rate.** The total charge capacity ( $Q_{Ch}$ ) shall be calculated as follows:

**F9.8.1 Secondary Coolant Systems.** For Thermal Storage Devices employing a Secondary Coolant as the charging fluid:

$$Q_{Ch} = Q_{Ch_{primary}} = (K_1) \int_{t_{Ch1}}^{t_{ChF}} W_{ChFM-3} c_p (T_6 - T_5) dt \quad F9$$

and for the confirming test calculation:

$$Q_{Ch_{confirm}} = (K_1) \int_{t_{Ch1}}^{t_{ChF}} [W_{CdFM-4} c_p (T_{10} - T_9) - P_{CM}] dt \quad F10$$

Where  $P_{CM}$ , is a work of compression plus, where applicable, the electric motor cooling load, such that:

For Open-type Compressors with electric motor drive:

$$P_{CM} = (kW_{ICM}) (K_2) (\eta_{motor}) (\eta_{drive}) \quad F11$$

and for Hermetic Compressors:

$$P_{CM} = (kW_{ICM}) (K_2) \quad F12$$

Then, for the test to be valid, the following relationships shall hold:

$$\left| \frac{Q_{Ch_{confirm}}}{Q_{Ch_{primary}}} - 1 \right| < 0.05 \quad F13$$

$$\left| \frac{Q_D + Q_{amb} + Q_{paras}}{Q_{Ch}} - 1 \right| < 0.05 \quad F14$$

The average Charge Rate ( $\overline{q_{Chp}}$ ) for each Period comprising the Charge Cycle shall be calculated as:

$$\overline{q_{Chp}} = (K_1) \left( \frac{1}{n} \right) \sum_{i=1}^n W_{R_n} (h_{R_6} - h_{R_5}) \quad F15$$

The average Charge Rate over the duration of the Charge Cycle shall be calculated as:

$$\overline{q_{Ch}} = \left( \frac{Q_{Ch}}{\tau_{Ch}} \right) \quad F16$$

and the average Charge Rate over the duration of the initial Charge Cycle as:

$$\overline{q_{IC}} = \left( \frac{Q_{IC}}{\tau_{IC}} \right) \quad F17$$

For the initial charge cycle test to be valid, the following relationship shall hold:

$$\left| \frac{\overline{q_{IC}}}{\overline{q_{Ch}}} - 1 \right| \leq 0.05 \quad F18$$

**F9.8.2 Refrigerant Systems.** For Thermal Storage Devices employing a refrigerant as the Charging Fluid:

$$Q_{Ch_{primary}} = (K_1) \int_{t_{Ch1}}^{t_{ChF}} W_R (h_{R_6} - h_{R_5}) dt \quad F19$$

$$Q_{Ch_{confirm}} = (K_1) \int_{t_{Ch1}}^{t_{ChF}} [W_{CdFM-4} c_p (T_{10} - T_9) - P_{CM}] dt \quad F20$$

Where  $P_{CM}$ , the work of compression plus, where applicable, the electric motor cooling load, as determined by Equations F11 and F12.

Then, for the test to be valid, it shall satisfy the requirements of Equations F13 and F14.

The average Charge Rate ( $\overline{q_{Ch}}$ ) for each Period comprising the charge cycle test shall be calculated as:

$$\overline{q_{Ch_p}} = (K_1) \left( \frac{1}{n} \right) \sum_{i=1}^n W_{ChFM-3n} c_p (T_{6_n} - T_{5_n}) \quad F21$$

**F9.9 Average Charge Temperatures.** The average charge temperatures will be the time weighted average of the entire Charge Period.

**F9.9.1** For Thermal Storage Devices using a Secondary Coolant for the heat transfer fluid during the charging cycle, the average entering and leaving temperatures shall be calculated as follows:

$$\overline{T_5} = \left( \frac{1}{\tau_{Ch}} \right) \int_{t_{ChI}}^{t_{ChF}} T_5 \, dt \quad F22$$

$$\overline{T_6} = \left( \frac{1}{\tau_{Ch}} \right) \int_{t_{ChI}}^{t_{ChF}} T_6 \, dt \quad F23$$

**F9.9.2** For Thermal Storage Devices using a refrigerant for the heat transfer fluid during the charging cycle, the average suction temperature shall be calculated as follows:

$$\overline{T_6} = \left( \frac{1}{\tau_{Ch}} \right) \int_{t_{ChI}}^{t_{ChF}} T_6 \, dt \quad F24$$

**F9.10 Minimum Charge Temperature.** The minimum charge temperature is the lowest temperature of the charging fluid (as measured at TS-6) that was required during the charge cycle (normally the temperature when the charge cycle test was terminated).

**F9.11 Initial Charge Time.** The initial charge time shall be equal to the time elapsed between the start and the end of the initial charge test. These data are required since the time required to initially charge the device may be longer than the recharge because in some storage devices some residual cooling shall be left in the device in order for it to perform properly.

Therefore, it is important to know the time required to initially charge the device or to recharge it, if for some reason the device is totally discharged when in normal operation.

**F10 Test Evaluation.**

**F10.1 Procedure.** The thermal performance of the Thermal Storage Device shall be evaluated by comparing the measured test data averaged over each Period comprising the test cycle to the performance predicted by the manufacturer's rating methodology for the corresponding Period.

**F10.1.1 Charge Cycle Test.** To determine the temperatures of the charging fluid entering and leaving the Thermal Storage Device as predicted by the manufacturer's rating methodology, use the average Charge Rate in Equation F16 as the chiller capacity and the measured flow rate of the heat transfer fluid as the input.

For the charge rating to be verified, the measured fluid temperatures averaged for each Period of the charge cycle test ( $q_{Chp}$ ) and the minimum fluid temperature attained during the test cycle shall be no less than 0.5°F below the corresponding values predicted by the rating methodology for that Period.

**F10.1.2 Discharge Cycle Test.** To determine the temperatures of the Discharge Fluid entering and leaving the Thermal Storage Device for each Period, as predicted by the manufacturer's rating methodology use the average Discharge Rate for each Period of the discharge cycle test, (Equation F5) as the load profile and the corresponding measured flow rate of the heat transfer fluid as input for each Period.

For the discharge rating to be verified, the measured fluid temperatures averaged over each Period of the discharge cycle shall be no greater than 0.5°F above those values predicted by the rating methodology for that Period.

**F11 Test Report.**

**F11.1 General Information.** A written test report shall be prepared and distributed to the parties involved in the test. Included in the introduction to the report shall be:

**F11.1.1** The name and address of the test facility

**F11.1.2** The name(s), title(s) and affiliation(s) of those persons conducting the test, witnessing the test, and preparing the test report. Also included shall be the name, title, and signature of the person(s) accepting responsibility for the content of the report

**F11.1.3** The date the test was conducted and the date of the report

**F11.1.4** The name and address of the client

**F11.1.5** The method by which the test unit was selected (i.e. random selection) and its condition

**F11.2 Test Unit Description.** The report shall include a full description of the test unit, using as a minimum the data specified in Section F8.4.

**F11.3 Test System Description.** A description of the test facility and primary apparatus shall be included in the report, complete with a system diagram showing the interconnecting piping and the locations of the principle components and instrumentation. Also included in this section shall be the specifics of the heat transfer fluid(s) employed for the test, including the basic data specified in Section F8.4.5.

**F11.4 Test Unit Data.** The report shall include a summary of the unit performance with following overall data and calculation results:

**F11.4.1** The Net Usable Storage Capacity,  $Q_D$ , ton-hour

**F11.4.2** The type(s) of heat transfer fluid(s) used in the Charge Cycle and Discharge Cycle

**F11.4.3** The duration for the initial Charge Cycle, h

**F11.4.4** The average Charge Rate ( $\overline{q_{IC}}$ ) for the initial Charge Cycle, tons

**F11.4.5** The time weighted inlet and outlet temperatures over the duration of the initial Charge Cycle, °F

**F11.4.6** The total capacity ( $Q_{IC}$ ) for the initial Charge Cycle, ton-hour

**F11.4.7** The duration of the Discharge Cycle, h

**F11.4.8** The average Discharge Rate ( $\overline{q_D}$ ) during the Discharge Cycle, tons



**F11.4.9** The maximum temperature attained by the heat transfer fluid leaving the storage device during the Discharge Cycle, °F

**F11.4.10** The duration of the Charge Cycle, h

**F11.4.11** The average Charge Rate ( $\overline{q_{Ch}}$ ) of the Charge Cycle, tons

**F11.4.12** The time weighted inlet and outlet temperatures over the duration of the Charge Cycle, °F

**F11.4.13** The total capacity ( $Q_{Ch}$ ) of the Charge Cycle, ton-hour

**F11.4.14** The pressure drop of the heat transfer fluid across the Thermal Storage Device, psi, at the maximum flow rate during the Discharge Cycle and, for devices using a Secondary Coolant as the Charge Fluid, the pressure drop across the Thermal Storage Device, psi, at the maximum flow rate during the Charge Cycle

**F11.4.15** Table F1, for both the Charge Cycle and the Discharge Cycle, comparing the measured temperatures of the heat transfer fluid as it enters and leaves the Thermal Storage Device, averaged over each Period comprising the test cycle, to the temperatures predicted by the rating methodology for the corresponding Period. For Thermal Storage Devices using a refrigerant as the Charge Fluid, use the saturated suction temperature

**F11.4.16** A copy of the performance of the Thermal Storage Device as predicted by the manufacturer's rating methodology, when using the duration of the charge cycle test and the load profile imposed during the discharge cycle test as input.

**F11.5 Calculation Summary.** The report shall include a summary sheet showing the results of all calculations for each reading along with an example of the complete calculations for one set of readings. Also included in this section shall be a statement of compliance with or deviation from the provisions in this code for "steady state" conditions and other operating limits.

**F11.6 Raw Test Data.** The raw test data shall be compiled and recorded in a legible form and included in the report. Hard copy shall be included even if data are also stored on electronic media.

**F11.7 Instrument Summary.** The report shall include a tabulation of all instruments used in the test including the serial number, latest calibration date, and the means by which the instrument was calibrated.

Table F1. Temperature Comparison – Charge and Discharge Cycles							
Period	Charge or Discharge Rate, q, tons	Temperature of Heat Transfer Fluid Entering Storage Device, °F			Temperature of Heat Transfer Fluid Leaving Storage Device, °F		
		Measured	Predicted	Difference	Measured	Predicted	Difference
#1							
#2							
#...							
#p							